

MX20***** - MPXPRO Collegamenti elettrici e di rete/MPXPRO Wiring and network connections/Connexions électriques et de réseau/Elektro- und Netzwerkanlüsse CAREL



**LEGGI E CONSERVA QUESTE ISTRUZIONI
READ AND SAVE THESE INSTRUCTIONS**

General description

This technical leaflet describes the MPXPRO family, highlighting the electrical connections for the main board, the options and the accessories. All the components are described in the full-optional versions. Consequently, this represents the maximum possible application of the MPXPRO. Other simpler possibilities depend on the specific product codes and applications.

Models:

CAREL CODE	MODEL	RS485 & RTC	RELAY MAP (see the wiring diagram)	PROBES	PWM outputs	EXPANSION BOARD (installed on the main board)
MX20M00EO	Master	✓	R1,R2,R3,R4,R5	NTC	-	-
MX20S00EO	Slave	-	R1,R2,R3,R4,R5	NTC	-	-
MX20S10EO	Slave	-	R1,R3,R5	NTC	-	-
MX20M21EO	Master	✓	R1,R2,R3,R4,R5	NTC/PTC/PT1000	2	-
MX20S21EO	Slave	-	R1,R2,R3,R4,R5	NTC/PTC/PT1000	2	-
MX20S31EO	Slave	-	R1,R3,R5	NTC/PTC/PT1000	2	-
MX20M25EO	Master	✓	R1,R2,R3,R4,R5	NTC/PTC/PT1000	2	CAREL E2V DRIVER +0...10 VDC output
MX20S25EO	Slave	-	R1,R2,R3,R4,R5	NTC/PTC/PT1000	2	CAREL E2V DRIVER +0...10 VDC output
MX20M24EO	Master	✓	R1,R2,R3,R4,R5	NTC/PTC/PT1000	2	PWM DRIVER +0...10 VDC output
MX20S24EO	Slave	-	R1,R2,R3,R4,R5	NTC/PTC/PT1000	2	PWM DRIVER +0...10 VDC output

Tab. 1

Warning:

- The board must not be installed on surfaces that exceed 70 °C (50 °C ambient) and 80 °C (60 °C ambient);
- Use with an external disconnect switch positioned near the appliance that is compliant with the IEC60947-1 and IEC60947-3 standards;
- Use cables with a temperature rating of 90 °C, if the temperature of the terminals exceeds 85 °C use a cable with a temperature rating of 105 °C;
- The connection cables must guarantee insulation up to 90 °C and if necessary up to 105 °C, when the temperature of the relay terminals exceeds 85 °C;
- If the appliance is used in a way that is not specified by the manufacturer, the guaranteed protection of the appliance may be compromised;
- If the current is higher than 6 amps in R1, R2, R3, R4, R5, use only cables with a section of 2.5 mm² (14 AVG);
- The board must not be accessible to people without warrant of installing.

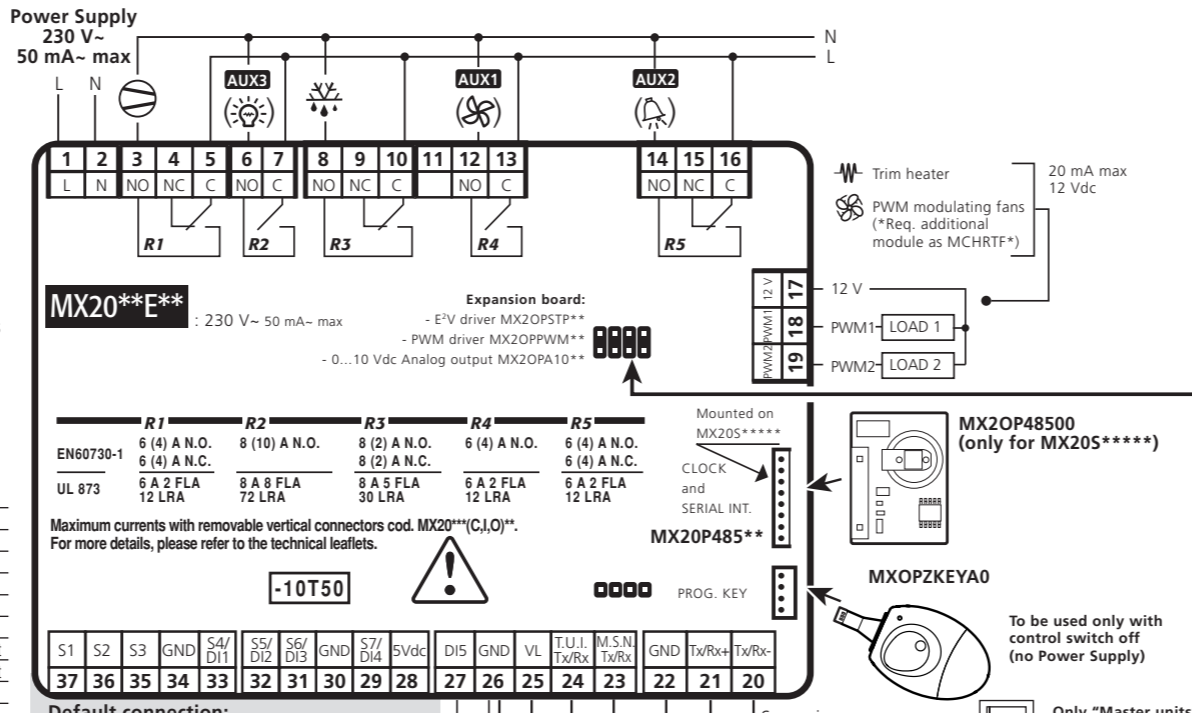

Default connection:

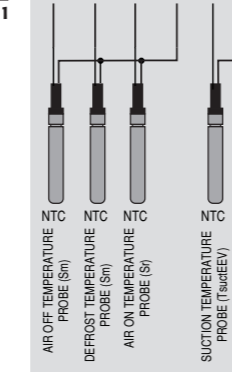

Possible connection:

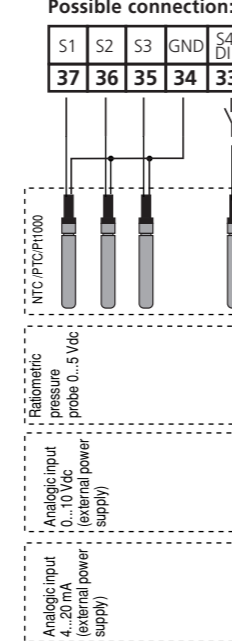

Pressure probe connection:

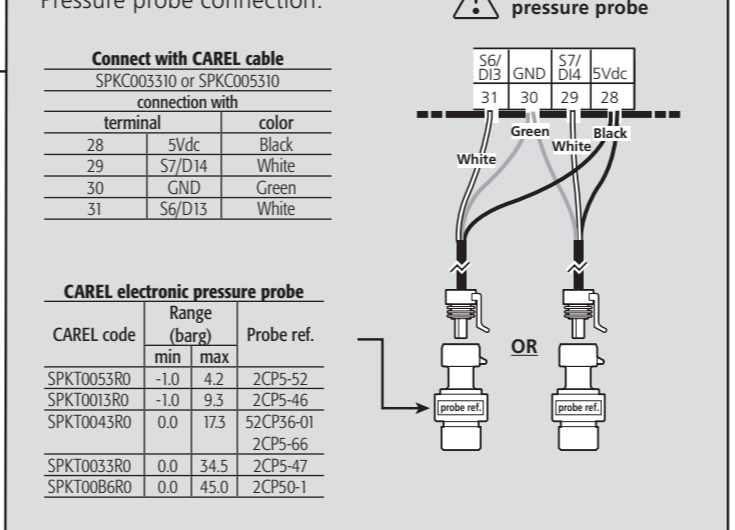

E2V Driver

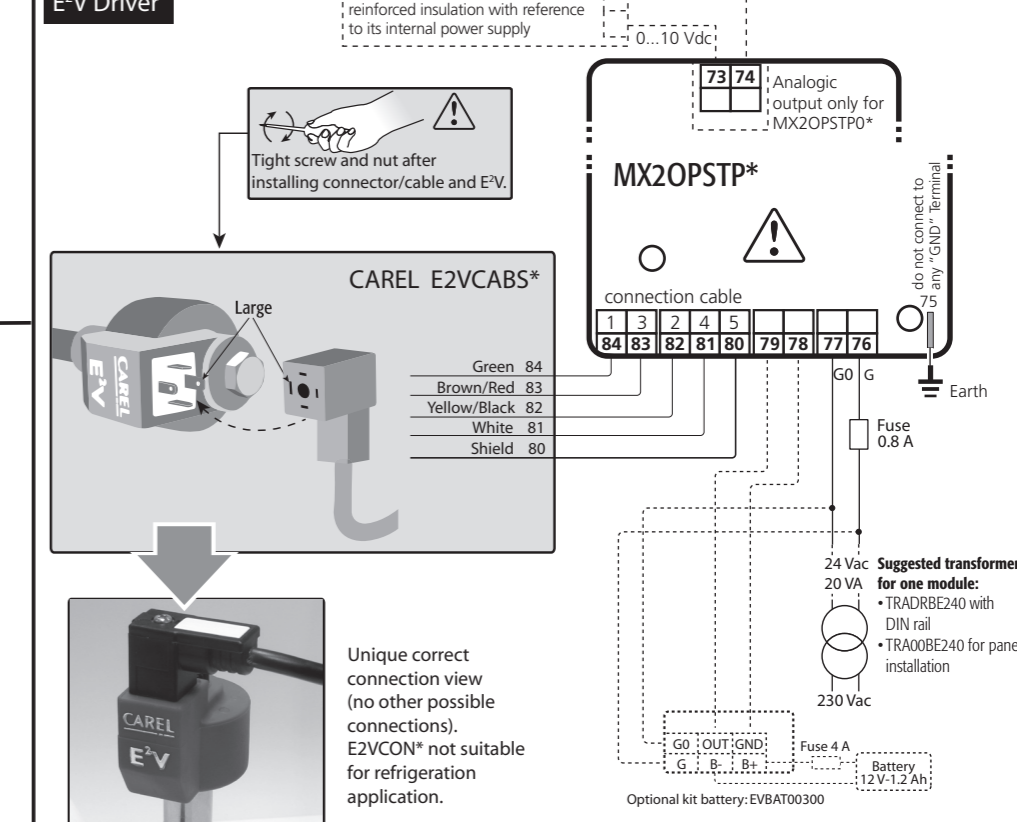

PWM Driver

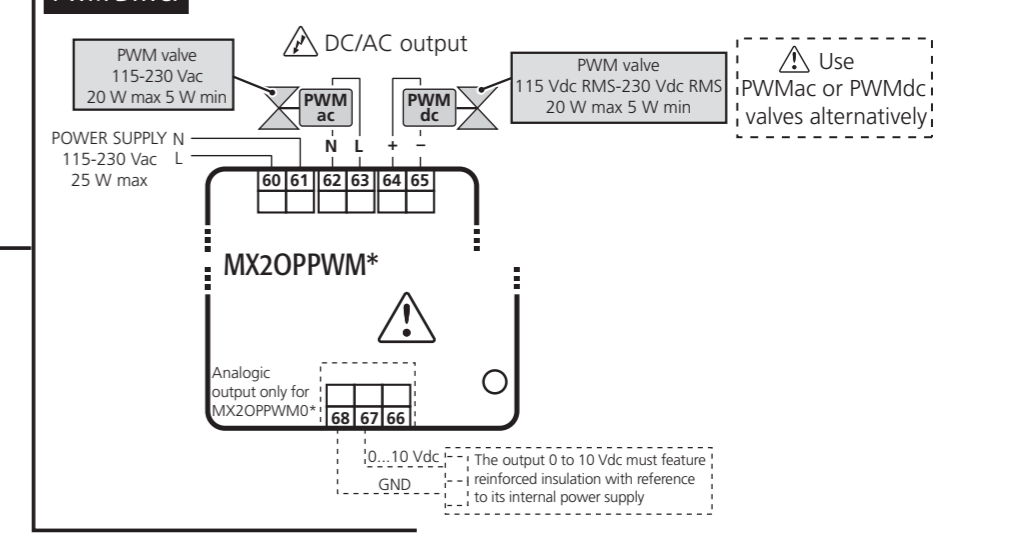

Analogic 0...10 Vdc

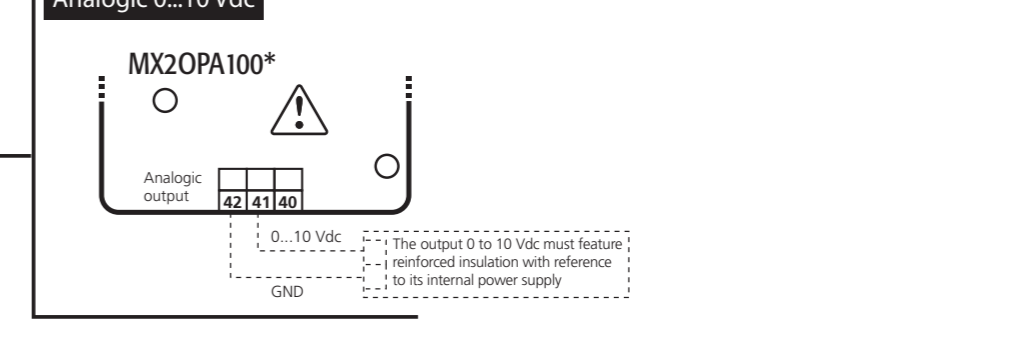

- I Smaltimento del prodotto**
L'apparecchiatura (o il prodotto) deve essere oggetto di raccolta separata in conformità alle vigenti normative locali in materia di smaltimento.
 - GB Disposal of the product**
The appliance (or the product) must be disposed of separately in compliance with the local standards in force on waste disposal.
 - F Élimination du produit**
L'équipement (ou le produit) doit faire l'objet d'un ramassage particulier en conformité avec les normes en vigueur locales en matière d'élimination des déchets.
 - D Entsorgung des Produktes**
Das Gerät (oder Produkt) muss im Mülltrennungsverfahren in Übereinstimmung mit den örtlichen Entsorgungsnormen entsorgt werden.
- I AVVERTENZE IMPORTANTI:** Il prodotto CAREL è un prodotto avanzato, il cui funzionamento è specificato nella documentazione tecnica fornita col prodotto o scaricabile, anche anteriormente all'acquisto, dal sito internet www.carel.com. Il cliente (costruttore, progettista o installatore dell'equipaggiamento finale) si assume ogni responsabilità e rischio in relazione alla fase di configurazione del prodotto per il raggiungimento dei risultati previsti in relazione all'installazione e/o equipaggiamento finale specifico. La mancanza di tale fase di studio, la quale è richiesta/indicata nel manuale d'uso, può generare malfunzionamenti nei prodotti finali di cui CAREL non potrà essere ritenuta responsabile. Il cliente finale deve usare il prodotto solo nelle modalità descritte nella documentazione relativa al prodotto stesso. La responsabilità di CAREL in relazione al proprio prodotto è regolata dalle condizioni generali di contratto CAREL editate nel sito www.carel.com e/o da specifici accordi con i clienti.
- GB IMPORTANT WARNINGS:** The CAREL product is a state-of-the-art device, whose operation is specified in the technical documentation supplied with the product or can be downloaded, even prior to purchase, from the website www.carel.com. The customer (manufacturer, developer or installer of the final equipment) accepts all liability and risk relating to the configuration of the product in order to reach the expected results in relation to the specific installation and/or equipment. The failure to complete such phase, which is required/indicated in the user manual, may cause the final product to malfunction; CAREL accepts no liability in such cases. The customer must use the product only in the manner described in the documentation relating to the product. The liability of CAREL in relation to its products is specified in the CAREL general contract conditions, available on the website www.carel.com and/or by specific agreements with customers.
- F AVERTISSEMENTS IMPORTANTS:** Le produit CAREL est un produit avancé dont le fonctionnement est spécifié dans la documentation technique fournie avec le produit ou téléchargeable, même avant l'achat, du site Internet www.carel.com. Le client (constructeur, concepteur ou installateur de l'équipement final) assume toutes les responsabilités et risques quant à la configuration du produit pour l'obtention des résultats prévus quant à l'installation et/ou à l'équipement final spécifique. L'absence de cette phase d'étude qui est requise/indiquée dans le manuel d'instructions peut provoquer des dysfonctionnements des produits finals dont CAREL ne pourra en aucun cas être jugée responsable. Le client final doit utiliser le produit exclusivement selon les modes décrits dans la documentation correspondant au produit. La responsabilité de CAREL en ce qui concerne son produit est réglée par les conditions générales de contrat CAREL publiées sur le site www.carel.com et/ou par des accords spécifiques stipulés avec les clients.
- D WICHTIGE HINWEISE:** Das CAREL Produkt ist ein Produkt nach dem neuesten Stand der Technik, dessen Betriebsanleitungen in den dem Produkt beiliegenden technischen Spezifikationen enthalten sind oder - auch vor dem Kauf - von der Internetseite www.carel.com heruntergeladen werden können. Der Kunde (Hersteller, Planer oder Installateur der Endausstattung) übernimmt jede Haftung und Risiken in Bezug auf die Produktkonfiguration zur Erzielung der bei der Installation und/oder spezifischen Endausstattung vorgesehenen Resultate. Die Unterlassung dieser Phase, die im Benutzerhandbuch verlangt/angegeben ist, kann zu Funktionsstörungen der Endprodukte führen, für welche CAREL nicht verantwortlich gemacht werden kann. Der Endkunde darf das Produkt nur auf die in den Produktspezifikationen beschriebenen Weisen verwenden. Die Haftung CARELS für die eigenen Produkte ist von den allgemeinen CAREL Vertragsbedingungen (siehe Internetseite www.carel.com) und/oder durch spezifische Vereinbarungen mit den Kunden geregelt.

