



Thermostatic Expansion valves, type TUA/TUAE

Contents

	Page
Introduction.....	3
Features.....	3
Standard range.....	3
Technical data.....	4
MOP valves.....	4
Identification.....	4
Ordering.....	5
Capacity	
R22.....	7
R134A.....	9
R404A/ R507.....	10
R407C.....	12
R410A.....	14
Design/Function.....	15
Dimensions and weight.....	15

Introduction

TUA/TUAE valves are made of stainless steel and are therefore very suitable for refrigeration systems in the food industry.

TUA/TUAE valves are available with interchangeable orifice assembly in straightway versions.

TUA/TUAE has been specially developed for soldering into hermetic refrigeration systems.

TUA/TUAE valves can be used in many different forms of refrigeration systems, for example:

- Traditional refrigeration systems
- Heat pump systems
- Air conditioning units
- Refrigeration appliances
- Liquid coolers
- Ice cube machines
- Mobile refrigeration systems

Features

- Interchangeable orifice assembly designed for:
 - Easy mounting
 - Optimized tightness
- Bimetal connections
 - Simple, fast soldering without the need for wet cloth or refrigeration pliers.
- Refrigerants
R22, R134a, R404A, R407C, R507, R410A and future refrigerants
- Capacities from 0.6 to 16 kW (0.17 to 4.5 TR) for R22
 - Large capacity range in small steps
- Stable regulation
- Biflow function (orifice 1 to 8)
- Compact design
 - small dimensions and low weight
- Stainless steel, solder version
 - high connection strength and tightness
 - capillary tube joints of high strength and vibration resistance
- Laser-welded, stainless steel thermostatic diaphragm element
 - optimum function
 - long diaphragm life
 - high pressure resistance
- Stainless steel bulb
 - simple and fast installation
 - good heat transfer from pipe to bulb
- Adjustable superheat
 - accurate setting
 - adjustable in operation
- Available with MOP (Max. Operating Pressure)
- Wide range of valves
- Interchangeable filter for easy cleaning
- Bleed orifices available on special request

Standard range

The standard range can be supplied in the following versions:

<i>Range N</i>	-40 to +10°C, without MOP
<i>Range N</i>	-40 to +10°C, MOP +15°C
<i>Range NM</i>	-40 to -5°C, MOP 0°C
<i>Range B</i>	-60 to -25°C, without MOP
<i>Range B</i>	-60 to -25°C, MOP -20°C

Valves for special temperature ranges can be supplied.

<i>Static superheat (SS) (R22, R134a, R404A, R407C and R410A):</i>	
Valves without MOP	5 K
Valves with MOP	4 K

<i>Static superheat (SS) (R507):</i>	
Valves without MOP	6.4 K
Valves with MOP	5.4 K
<i>Capillary tube length</i>	1.5 m
<i>Connections:</i>	
Inlet	1/4 in./6 mm
	3/8 in./10 mm
Outlet	1/2 in./12 mm

Technical data

<i>Max. bulb temperature</i>	100°C
<i>Max. valve body temp. short-lived peak</i>	120°C, 150°C
<i>Permissible working pressure (excl. R410A)</i>	PS = 34 bar
<i>Max. test pressure (excl. R410A)</i>	p' = 37.5 bar
<i>Max. working pressure, R410A</i>	PS = 42.5 bar
<i>Max. test pressure, R410A</i>	p' = 47 bar

Biflow drift

With flow in the opposite direction, the rated capacity is reduced by up to 15%.
TUAE with orifice 0 and 9, all TUA and valves with MOP charges cannot be used for biflow operation.

MOP valves

When MOP valves are used, to avoid charge migration the bulb temperature must always be lower than the thermostatic element temperature.

MOP-points

Refrigerant	Range N -40 → +10°C	Range NM -40 → -5°C	Range B -60 → -25°C
	MOP point for evaporating temperature t_e and evaporating pressure p_e ¹⁾ $t_e = +15°C/+60°F$ $t_e = 0°C/+32°F$ $t_e = -20°C/-4°F$		
R22	$p_e = 100$ psig/6.9 bar	$p_e = 60$ psig/4.0 bar	$p_e = 20$ psig/1.5 bar
R134a	$p_e = 55$ psig/3.9 bar	$p_e = 30$ psig/1.9 bar	
R404A/R507	$p_e = 120$ psig/8.4 bar	$p_e = 75$ psig/5.0 bar	$p_e = 30$ psig/2.0 bar
R407C	$p_e = 95$ psig/6.6 bar	$p_e = 50$ psig/3.6bar	$p_e = 20$ psig/1.4 bar
R410A	$p_e = 165$ psig/11.5 bar	$p_e = 100$ psig/7.0 bar	$p_e = 45$ psig/3.0 bar

¹⁾ p_e in bar gauge

Identification

Main valve data is given on the element (fig. 1), on the valve body (fig. 2) and on the bottom of the orifice assembly (fig. 3).

Example valve body

TUAE	= Type (E = external pressure equalisation)
068U2214	= Code number
R134a	= Refrigerant
MOP 55 / +15°C	= MOP-point in psig / °C
-40 / +10°C	= Evaporating temperature range in °C
-40 / +50°F	= Evaporating temperature range in °F
PS 34 bar/ MWP 500 psig	= Max. working pressure in bar/psig
1004B	= Date marking (week 10 , year 2004 , weekday B = Tuesday)
⇒	= Normal flow direction
in.	= Connection in inches (mm = millimetres)

Example orifice assembly

TU	= Valve type
5	= Orifice number
068U1035	= Code no., orifice assembly incl. filter and gasket
104	= Date marking (Week 10 , Year 2004)

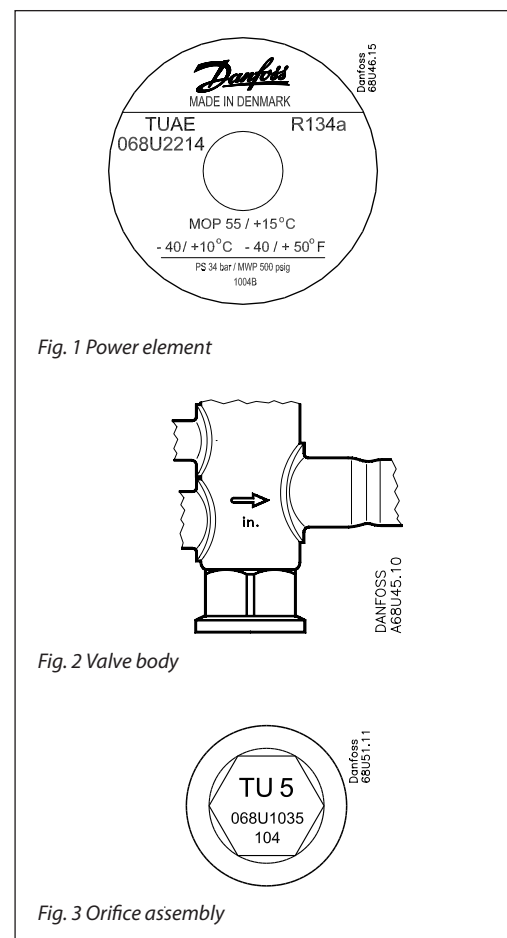

Ordering, components with solder x solder connections
*Thermostatic element, without orifice
and filter, with bulb strap*
R22, R134a, R404A, R407C, R507, R410A

Refrigerant	Valve type	Pressure equalization ¹⁾	Capillary tube m	Connections		Code no.				
				Inlet x outlet		Range N -40 → +10°C		Range NM -40 → -5°C	Range B -60 → -25°C	
				in.	mm	Without MOP	MOP +15 °C	MOP 0 °C	Without MOP	MOP -20°C
R22	TUA	Int.	1.5	1/4 x 1/2	6 x 12	068U2234	068U2242			
	TUA	Int.	1.5			068U2230	068U2238			
	TUA	Int.	1.5	3/8 x 1/2		068U2235	068U2243			
	TUA	Int.	1.5		10 x 12	068U2231	068U2239			
	TUAE	Ext. 1/4 in.	1.5	1/4 x 1/2	6 x 12	068U2236	068U2244			
	TUAE	Ext. 6 mm	1.5			068U2232	068U2240			
	TUAE	Ext. 1/4 in.	1.5	3/8 x 1/2		068U2237	068U2245			
	TUAE	Ext. 6 mm	1.5		10 x 12	068U2233	068U2241			
R134a	TUA	Int.	1.5	1/4 x 1/2	6 x 12	068U2204	068U2212			
	TUA	Int.	1.5			068U2200	068U2208			
	TUA	Int.	1.5	3/8 x 1/2		068U2205	068U2213			
	TUA	Int.	1.5		10 x 12	068U2201	068U2209			
	TUAE	Ext. 1/4 in.	1.5	1/4 x 1/2	6 x 12	068U2206	068U2214			
	TUAE	Ext. 6 mm	1.5			068U2202	068U2210			
	TUAE	Ext. 1/4 in.	1.5	3/8 x 1/2		068U2207	068U2215			
	TUAE	Ext. 6 mm	1.5		10 x 12	068U2203	068U2211			
R404A R507	TUA	Int.	1.5	1/4 x 1/2	6 x 12	068U2284	068U2292	068U2300	068U2308	068U2316
	TUA	Int.	1.5			068U2280	068U2288	068U2296	068U2304	068U2312
	TUA	Int.	1.5	3/8 x 1/2		068U2285	068U2293	068U2301	068U2309	068U2317
	TUA	Int.	1.5		10 x 12	068U2281	068U2289	068U2297	068U2305	068U2313
	TUAE	Ext. 1/4 in.	1.5	1/4 x 1/2	6 x 12	068U2286	068U2294	068U2302	068U2310	068U2318
	TUAE	Ext. 6 mm	1.5			068U2282	068U2290	068U2298	068U2306	068U2314
	TUAE	Ext. 1/4 in.	1.5	3/8 x 1/2		068U2287	068U2295	068U2303	068U2311	068U2319
	TUAE	Ext. 6 mm	1.5		10 x 12	068U2283	068U2291	068U2299	068U2307	068U2315
R407C	TUA	Int.	1.5	1/4 x 1/2	6 x 12	068U2324	068U2332			
	TUA	Int.	1.5			068U2320	068U2328			
	TUA	Int.	1.5	3/8 x 1/2		068U2325	068U2333			
	TUA	Int.	1.5		10 x 12	068U2321	068U2329			
	TUAE	Ext. 1/4 in.	1.5	1/4 x 1/2	6 x 12	068U2326	068U2334			
	TUAE	Ext. 6 mm	1.5			068U2322	068U2330			
	TUAE	Ext. 1/4 in.	1.5	3/8 x 1/2		068U2327	068U2335			
	TUAE	Ext. 6 mm	1.5		10 x 12	068U2323	068U2331			
R410A	TUA	Int.	1.5	3/8 x 1/2		068U2414				
	TUAE	Ext. 1/4 in.	1.5	3/8 x 1/2	10 x 12	068U1714				
	TUAE	Ext. 6 mm	1.5			068U2780				

Ordering (continued)
Orifice assembly with filter and gasket. Range N: -40 → +10°C

Orifice no.	Rated capacity in kW ¹⁾						Rated capacity in tons (TR) ¹⁾						Code no.
	R22	R134a	R404A	R407C	R507	R410A	R22	R134a	R404A	R407C	R507	R410A	
0	0.60	0.47	0.47	0.63	0.45	-	0.17	0.13	0.13	0.18	0.13	-	068U1030
1	0.9	0.7	0.70	0.92	0.66	1.3	0.25	0.19	0.19	0.26	0.19	0.4	068U1031
2	1.3	1.0	1.0	1.4	1.0	2.1	0.36	0.28	0.28	0.38	0.27	0.6	068U1032
3	1.8	1.4	1.4	1.9	1.3	2.9	0.50	0.39	0.39	0.53	0.38	0.8	068U1033
4	2.6	2.1	2.1	2.8	2.0	4.5	0.75	0.59	0.60	0.80	0.57	1.3	068U1034
5	3.5	2.7	2.8	3.8	2.7	5.9	1.00	0.78	0.79	1.1	0.76	1.7	068U1035
6	5.3	4.1	4.2	5.7	4.0	9.0	1.5	1.2	1.2	1.6	1.1	2.5	068U1036
7	7.0	5.5	5.6	7.5	5.3	12.0	2.0	1.6	1.6	2.1	1.5	3.4	068U1037
8	11.0	8.2	8.4	11.0	8.0	18.0	3.0	2.3	2.4	3.2	2.3	5.0	068U1038
9	16.0	12.0	12.0	17.0	12.0	26.0	4.5	3.5	3.5	4.8	3.4	7.5	068U1039

Range B: -60 → -25°C

Orifice no.	Rated capacity in kW ¹⁾				Rated capacity in tons (TR) ¹⁾				Code no.
	R22	R404A	R407C	R507	R22	R404A	R407C	R507	
0	0.52	0.36	0.46	0.39	0.15	0.10	0.13	0.11	068U1030
1	0.68	0.50	0.58	0.53	0.19	0.14	0.16	0.15	068U1031
2	0.85	0.64	0.70	0.70	0.24	0.18	0.20	0.20	068U1032
3	1.2	0.89	1.0	1.0	0.34	0.25	0.28	0.28	068U1033
4	1.8	1.3	1.4	1.4	0.50	0.37	0.41	0.41	068U1034
5	2.3	1.8	1.9	1.9	0.66	0.50	0.55	0.55	068U1035
6	3.5	2.7	2.9	2.9	1.0	0.75	0.82	0.82	068U1036
7	4.7	3.5	3.9	3.9	1.3	1.0	1.1	1.1	068U1037
8	7.1	5.3	5.8	5.8	2.0	1.5	1.6	1.7	068U1038
9	10.4	7.8	8.5	8.6	2.9	2.2	2.4	2.4	068U1039

¹⁾ Rated capacity Q_{nom} is based on:
 Evaporating temperature
 $t_e = +5^\circ\text{C}$ for range N and -30°C for range B
 Condensing temperature
 $t_c = +32^\circ\text{C}$
 Refrigerant liquid temperature
 $t_l = +28^\circ\text{C}$
 Opening superheat OS = 4 K

Spare parts
Gasket (24 pcs.): 068U0015

 Note: to ensure tightness the orifice gasket *must* be exchanged each time the orifice assembly is unscrewed.

Filter (24 pcs.): 068U0016

Capacity

 Capacity in kW for range $N = -40 \rightarrow +10^\circ\text{C}$ and opening superheat $OS = 4\text{ K}$
R22

Valve type	Orifice no.	Pressure drop across valve Δp bar								Pressure drop across valve Δp bar							
		2	4	6	8	10	12	14	16	2	4	6	8	10	12	14	16
Evaporating temperature $+10^\circ\text{C}$										Evaporating temperature 0°C							
TU	0	0.42	0.53	0.60	0.65	0.68	0.70	0.71	0.72	0.40	0.50	0.56	0.60	0.63	0.65	0.67	0.67
	1	0.61	0.79	0.89	1.0	1.0	1.0	1.1	1.1	0.55	0.71	0.80	0.86	0.91	0.93	0.95	0.96
	2	0.9	1.2	1.3	1.5	1.6	1.6	1.7	1.7	0.73	1.0	1.1	1.2	1.3	1.3	1.4	1.4
	3	1.2	1.6	1.8	2.0	2.1	2.2	2.3	2.3	1.0	1.3	1.5	1.7	1.8	1.8	1.9	1.9
	4	1.8	2.4	2.8	3.1	3.2	3.4	3.5	3.5	1.5	2.0	2.3	2.5	2.7	2.8	2.8	2.8
	5	2.4	3.2	3.7	4.1	4.3	4.5	4.6	4.7	2.0	2.7	3.1	3.4	3.5	3.7	3.8	3.8
	6	3.7	4.9	5.6	6.1	6.5	6.7	6.9	7.1	3.1	4.0	4.6	5.0	5.3	5.5	5.7	5.8
	7	4.9	6.5	7.5	8.2	8.6	9.0	9.2	9.4	4.1	5.4	6.2	6.7	7.1	7.4	7.6	7.7
	8	7.3	9.6	11.2	12.2	12.9	13.4	13.7	13.9	6.1	8.0	9.2	10.1	10.6	11.0	11.3	11.5
9	10.9	14.5	16.7	18.2	19.3	20.0	20.5	20.9	9.1	12.1	13.8	15.0	15.9	16.4	16.8	17.1	
Evaporating temperature -10°C										Evaporating temperature -20°C							
TU	0	0.36	0.46	0.51	0.55	0.57	0.59	0.60	0.61	0.40	0.45	0.48	0.50	0.52	0.53	0.53	
	1	0.47	0.62	0.70	0.75	0.79	0.81	0.82	0.83	0.51	0.57	0.62	0.65	0.67	0.68	0.69	
	2	0.60	0.78	0.89	1.0	1.0	1.1	1.1	1.1	0.61	0.70	0.76	0.79	0.82	0.84	0.85	
	3	0.8	1.1	1.3	1.4	1.4	1.5	1.5	1.5	0.9	1.0	1.1	1.1	1.2	1.2	1.2	
	4	1.2	1.6	1.9	2.0	2.1	2.2	2.2	2.3	1.3	1.5	1.6	1.6	1.7	1.7	1.8	
	5	1.7	2.2	2.5	2.7	2.8	2.9	3.0	3.0	1.7	1.9	2.1	2.2	2.3	2.3	2.3	
	6	2.5	3.2	3.7	4.0	4.3	4.4	4.5	4.6	2.5	2.9	3.1	3.3	3.4	3.5	3.5	
	7	3.3	4.3	5.0	5.4	5.7	5.9	6.0	6.1	3.4	3.9	4.2	4.4	4.5	4.6	4.7	
	8	5.0	6.5	7.5	8.1	8.5	8.8	9.0	9.1	5.1	5.8	6.3	6.6	6.8	7.0	7.1	
9	7.4	9.7	11.1	12.0	12.6	13.1	13.3	13.5	7.6	8.6	9.3	9.7	10.1	10.3	10.4		
Evaporating temperature -30°C										Evaporating temperature -40°C							
TU	0		0.34	0.40	0.42	0.44	0.44	0.45			0.31	0.33	0.34	0.35	0.36	0.36	
	1		0.39	0.45	0.48	0.51	0.52	0.53	0.54			0.33	0.36	0.38	0.39	0.39	0.40
	2		0.47	0.53	0.57	0.60	0.62	0.63	0.63			0.39	0.42	0.44	0.45	0.46	0.46
	3		0.66	0.74	0.80	0.84	0.87	0.88	0.89			0.55	0.59	0.61	0.63	0.64	0.65
	4		1.0	1.1	1.2	1.2	1.3	1.3	1.3			0.80	0.86	0.90	0.92	0.94	0.95
	5		1.3	1.5	1.6	1.7	1.7	1.7	1.8			1.1	1.2	1.2	1.2	1.3	1.3
	6		1.9	2.2	2.4	2.5	2.5	2.6	2.6			1.6	1.7	1.8	1.8	1.9	1.9
	7		2.6	2.9	3.2	3.3	3.4	3.5	3.5			2.1	2.3	2.4	2.5	2.5	2.5
	8		3.9	4.4	4.8	5.0	5.1	5.2	5.3			3.2	3.5	3.6	3.7	3.8	3.8
9		5.7	6.5	7.0	7.3	7.5	7.7	7.7			4.7	5.1	5.3	5.5	5.5	5.6	

Correction for subcooling Δt_{sub}

The evaporator capacity used must be corrected if subcooling deviates from 4 K.

The corrected capacity can be obtained by dividing the evaporator capacity by the correction factor given below.

Correction factor for subcooling Δt_{sub}

Δt_{sub}	4 K	10 K	15 K	20 K	25 K	30 K	35 K	40 K	45 K	50 K
Correction factor	1.00	1.06	1.11	1.15	1.2	1.25	1.3	1.35	1.39	1.44

Note:

Insufficient subcooling can produce flash gas.

Selection example

Refrigerant = R22

 Evaporating temperature $t_e = -10^\circ\text{C}$

 Pressure drop in valve $\Delta p = 10$ bar

 Subcooling $\Delta t_{sub} = 15$ K

Evaporator capacity = 3 kW

Correction value (table) = 1.11

The corrected evaporator capacity thus becomes 3 divided by 1.11 = 2.7 kW

Since the expansion valve capacity must be equal to or slightly more than the corrected evaporator capacity of 2.7 kW, a TUB/TUBE with orifice 5 and a table capacity of 2.8 kW would be a suitable choice.

Capacity (continued)

 Capacity in kW for range $B = -60 \rightarrow -25^\circ\text{C}$ and opening superheat $OS = 4\text{ K}$
R22

Valve type	Orifice no.	Pressure drop across valve Δp bar								Pressure drop across valve Δp bar							
		2	4	6	8	10	12	14	16	2	4	6	8	10	12	14	16
Evaporating temperature -25°C										Evaporating temperature -30°C							
TU	0	0.36	0.45	0.50	0.54	0.56	0.58	0.59	0.59	0.33	0.42	0.46	0.49	0.52	0.53	0.54	0.54
	1	0.48	0.62	0.69	0.74	0.77	0.79	0.81	0.81	0.42	0.54	0.61	0.66	0.68	0.70	0.71	0.72
	2	0.61	0.79	0.89	0.96	1.01	1.04	1.06	1.07	0.52	0.67	0.75	0.81	0.85	0.88	0.89	0.90
	3	0.85	1.10	1.25	1.34	1.41	1.45	1.48	1.50	0.73	0.93	1.1	1.1	1.2	1.2	1.3	1.3
	4	1.3	1.6	1.9	2.0	2.1	2.1	2.2	2.2	1.1	1.4	1.6	1.7	1.8	1.8	1.8	1.9
	5	1.7	2.2	2.5	2.7	2.8	2.9	2.9	3.0	1.4	1.9	2.1	2.2	2.4	2.4	2.5	2.5
	6	2.5	3.3	3.7	4.0	4.2	4.3	4.4	4.5	2.1	2.8	3.1	3.4	3.5	3.6	3.7	3.7
	7	3.4	4.4	5.0	5.4	5.6	5.8	5.9	6.0	2.9	3.7	4.2	4.5	4.7	4.9	4.9	5.0
	8	5.1	6.6	7.5	8.0	8.4	8.7	8.9	8.9	4.3	5.6	6.3	6.8	7.1	7.3	7.4	7.5
9	7.6	9.7	11.0	11.9	12.4	12.8	13.1	13.2	6.4	8.2	9.3	10.0	10.4	10.7	10.9	11.0	
Evaporating temperature -40°C										Evaporating temperature -50°C							
TU	0	0.27	0.34	0.37	0.40	0.42	0.43	0.43	0.44	0.20	0.25	0.28	0.30	0.31	0.32	0.33	0.33
	1	0.31	0.39	0.44	0.47	0.50	0.51	0.52	0.52	0.21	0.27	0.30	0.32	0.34	0.35	0.35	0.35
	2	0.36	0.46	0.52	0.56	0.59	0.60	0.61	0.62	0.25	0.31	0.35	0.38	0.39	0.40	0.41	0.41
	3	0.51	0.65	0.73	0.79	0.82	0.85	0.86	0.87	0.35	0.44	0.50	0.53	0.55	0.57	0.58	0.58
	4	0.75	0.96	1.1	1.2	1.2	1.2	1.3	1.3	0.51	0.65	0.72	0.77	0.81	0.83	0.84	0.85
	5	1.0	1.3	1.4	1.6	1.6	1.7	1.7	1.7	0.68	0.87	0.97	1.0	1.1	1.1	1.1	1.1
	6	1.5	1.9	2.2	2.3	2.4	2.5	2.5	2.6	1.0	1.3	1.4	1.5	1.6	1.7	1.7	1.7
	7	2.0	2.6	2.9	3.1	3.2	3.3	3.4	3.4	1.4	1.7	1.9	2.1	2.2	2.2	2.3	2.3
	8	3.0	3.9	4.4	4.7	4.9	5.0	5.1	5.2	2.1	2.6	2.9	3.1	3.3	3.4	3.4	3.4
9	4.5	5.7	6.4	6.8	7.1	7.3	7.5	7.5	3.0	3.8	4.3	4.6	4.8	4.9	5.0	5.0	
Evaporating temperature -60°C																	
TU	0	0.14	0.17	0.19	0.21	0.21	0.22	0.22	0.22								
	1	0.14	0.18	0.20	0.22	0.22	0.23	0.23	0.23								
	2	0.16	0.21	0.23	0.25	0.26	0.26	0.27	0.27								
	3	0.23	0.29	0.33	0.35	0.36	0.37	0.38	0.38								
	4	0.34	0.43	0.48	0.51	0.53	0.54	0.55	0.55								
	5	0.45	0.57	0.64	0.68	0.71	0.73	0.74	0.74								
	6	0.67	0.85	0.95	1.01	1.05	1.08	1.09	1.10								
	7	0.91	1.1	1.3	1.4	1.4	1.5	1.5	1.5								
	8	1.4	1.7	1.9	2.1	2.1	2.2	2.2	2.2								
9	2.0	2.5	2.8	3.0	3.1	3.2	3.2	3.2									

Correction for subcooling Δt_{sub}

The evaporator capacity used must be corrected if subcooling deviates from 4 K.

The corrected capacity can be obtained by dividing the evaporator capacity by the correction factor given below.

Note:

Insufficient subcooling can produce flash gas.

Correction factor for subcooling Δt_{sub}

Δt_{sub}	4 K	10 K	15 K	20 K	25 K	30 K	35 K	40 K	45 K	50 K
Correction factor	1.00	1.06	1.11	1.15	1.2	1.25	1.3	1.35	1.39	1.44

Capacity (continued)

 Capacity in kW for range $N = -40 \rightarrow +10^\circ\text{C}$ and opening superheat $OS = 4\text{ K}$
R134a

Valve type	Orifice no.	Pressure drop across valve Δp bar								Pressure drop across valve Δp bar							
		2	4	6	8	10	12	14	16	2	4	6	8	10	12	14	16
Evaporating temperature $+10^\circ\text{C}$										Evaporating temperature 0°C							
TU	0	0.38	0.46	0.50	0.53	0.54	0.54			0.35	0.42	0.46	0.48	0.49	0.49		
	1	0.57	0.69	0.76	0.79	0.81	0.81			0.50	0.61	0.66	0.69	0.70	0.71		
	2	0.82	1.1	1.2	1.2	1.3	1.3			0.66	0.84	0.93	0.98	1.0	1.0		
	3	1.1	1.4	1.6	1.7	1.8	1.8			0.92	1.2	1.3	1.4	1.4	1.4		
	4	1.7	2.2	2.5	2.6	2.7	2.7			1.4	1.8	1.9	2.0	2.1	2.1		
	5	2.3	2.9	3.3	3.5	3.6	3.6			1.8	2.3	2.6	2.7	2.8	2.8		
	6	3.4	4.4	4.9	5.2	5.4	5.5			2.8	3.5	3.9	4.1	4.2	4.3		
	7	4.6	5.9	6.6	7.0	7.2	7.2			3.7	4.7	5.2	5.5	5.6	5.7		
	8	6.8	8.7	9.8	10.3	10.6	10.8			5.5	7.0	7.8	8.2	8.4	8.5		
9	10.2	13.1	14.6	15.5	15.9	16.0			8.3	10.4	11.5	12.2	12.4	12.5			
Evaporating temperature -10°C										Evaporating temperature -20°C							
TU	0	0.31	0.37	0.40	0.42	0.43	0.43				0.31	0.34	0.35	0.35	0.35		
	1	0.41	0.51	0.55	0.58	0.58	0.58				0.39	0.43	0.44	0.45	0.45		
	2	0.51	0.64	0.70	0.74	0.75	0.76				0.47	0.51	0.53	0.54	0.54		
	3	0.71	0.89	0.98	1.0	1.1	1.1				0.65	0.72	0.75	0.76	0.76		
	4	1.1	1.3	1.5	1.5	1.6	1.6				0.96	1.05	1.10	1.12	1.1		
	5	1.4	1.8	2.0	2.1	2.1	2.1				1.3	1.4	1.5	1.5	1.5		
	6	2.1	2.7	2.9	3.1	3.1	3.2				1.9	2.1	2.2	2.2	2.2		
	7	2.8	3.5	3.9	4.1	4.2	4.2				2.6	2.8	3.0	3.0	3.0		
	8	4.3	5.3	5.9	6.2	6.3	6.3				3.9	4.3	4.4	4.5	4.5		
9	6.3	7.9	8.7	9.1	9.3	9.3				5.7	6.2	6.5	6.6	6.6			
Evaporating temperature -30°C										Evaporating temperature -40°C							
TU	0		0.25	0.27	0.28	0.28					0.18	0.19	0.20	0.20	0.20		
	1		0.28	0.30	0.32	0.32	0.32				0.19	0.21	0.21	0.21	0.21		
	2		0.32	0.35	0.37	0.37	0.37				0.22	0.24	0.25	0.25	0.25		
	3		0.46	0.50	0.52	0.53	0.52				0.31	0.34	0.35	0.35	0.35		
	4		0.67	0.73	0.76	0.77	0.76				0.45	0.49	0.50	0.51	0.51		
	5		0.90	0.98	1.02	1.03	1.0				0.61	0.66	0.68	0.68	0.68		
	6		1.3	1.5	1.5	1.5	1.5				0.90	0.97	1.0	1.0	1.0		
	7		1.8	2.0	2.0	2.1	2.1				1.2	1.3	1.4	1.4	1.4		
	8		2.7	3.0	3.1	3.1	3.1				1.8	2.0	2.1	2.1	2.1		
9		4.0	4.3	4.5	4.5	4.5				2.7	2.9	3.0	3.0	3.0			

Correction for subcooling Δt_{sub}

The evaporator capacity used must be corrected if subcooling deviates from 4 K. The corrected capacity can be obtained by dividing the evaporator capacity by the correction factor given below.

Note:

Insufficient subcooling can produce flash gas.

Correction factor for subcooling Δt_{sub}

Δt_{sub}	4 K	10 K	15 K	20 K	25 K	30 K	35 K	40 K	45 K	50 K
Correction factor	1.00	1.08	1.13	1.19	1.25	1.31	1.37	1.42	1.48	1.54

Capacity (continued)

 Capacity in kW for range $N = -40 \rightarrow +10^\circ\text{C}$ and opening superheat $OS = 4\text{ K}$
R404A/R507

Valve type	Orifice no.	Pressure drop across valve Δp bar								Pressure drop across valve Δp bar							
		2	4	6	8	10	12	14	16	2	4	6	8	10	12	14	16
Evaporating temperature +10°C										Evaporating temperature 0°C							
TU	0	0.32	0.40	0.44	0.46	0.46	0.46	0.45	0.44	0.31	0.39	0.42	0.44	0.44	0.44	0.43	0.42
	1	0.47	0.60	0.68	0.69	0.70	0.70	0.68	0.66	0.44	0.56	0.61	0.64	0.64	0.64	0.63	0.61
	2	0.70	0.91	1.0	1.1	1.1	1.1	1.1	1.1	0.60	0.77	0.87	0.92	0.94	0.94	0.93	0.90
	3	0.96	1.2	1.4	1.5	1.5	1.5	1.5	1.5	0.83	1.1	1.2	1.3	1.3	1.5	1.3	1.3
	4	1.5	1.9	2.1	2.3	2.3	2.3	2.3	2.2	1.3	1.6	1.8	1.9	2.0	2.0	1.9	1.9
	5	2.0	2.5	2.8	3.0	3.1	3.1	3.1	3.0	1.7	2.2	2.4	2.6	2.6	2.6	2.6	2.5
	6	2.9	3.8	4.3	4.5	4.7	4.7	4.6	4.5	2.5	3.2	3.6	3.8	3.9	3.9	3.9	3.8
	7	3.9	5.1	5.7	6.0	6.2	6.2	6.1	6.0	3.4	4.3	4.8	5.1	5.2	5.3	5.2	5.0
	8	5.8	7.5	8.4	9.0	9.2	9.2	9.1	8.9	5.0	6.5	7.2	7.6	7.8	7.8	7.7	7.5
9	8.8	11.3	12.7	13.5	13.8	13.9	13.7	13.39	7.5	9.6	10.8	11.4	11.7	11.7	11.5	11.2	
Evaporating temperature -10°C										Evaporating temperature -20°C							
TU	0	0.29	0.36	0.39	0.40	0.41	0.41	0.40	0.39	0.32	0.35	0.36	0.36	0.36	0.35	0.34	
	1	0.39	0.50	0.54	0.57	0.57	0.57	0.56	0.54	0.41	0.46	0.48	0.48	0.48	0.47	0.45	
	2	0.50	0.64	0.71	0.75	0.76	0.76	0.75	0.73	0.51	0.56	0.59	0.60	0.60	0.59	0.57	
	3	0.70	0.89	0.99	1.0	1.1	1.1	1.1	1.0	0.71	0.79	0.83	0.84	0.84	0.82	0.80	
	4	1.0	1.3	1.5	1.6	1.6	1.6	1.6	1.5	1.1	1.2	1.2	1.2	1.2	1.2	1.2	
	5	1.4	1.8	2.0	2.1	2.1	2.1	2.1	2.0	1.4	1.6	1.6	1.7	1.7	1.6	1.6	
	6	2.1	2.7	3.0	3.1	3.2	3.2	3.1	3.1	2.1	2.3	2.4	2.5	2.5	2.4	2.4	
	7	2.8	3.6	4.0	4.2	4.3	4.3	4.2	4.1	2.8	3.1	3.3	3.3	3.3	3.3	3.2	
	8	4.2	5.3	5.9	6.3	6.4	6.4	6.3	6.1	4.3	4.7	4.9	5.0	5.0	4.9	4.8	
9	6.2	7.9	8.8	9.3	9.5	9.5	9.3	9.0	6.3	6.9	7.3	7.4	7.4	7.2	7.0		
Evaporating temperature -30°C										Evaporating temperature -40°C							
TU	0			0.3	0.31	0.31	0.31	0.3	0.29			0.24	0.25	0.25	0.25	0.24	0.23
	1			0.36	0.38	0.38	0.38	0.37	0.36			0.27	0.28	0.28	0.28	0.27	0.26
	2			0.43	0.45	0.45	0.45	0.44	0.43			0.32	0.33	0.33	0.33	0.32	0.31
	3			0.60	0.63	0.64	0.63	0.62	0.60			0.45	0.46	0.47	0.46	0.45	0.43
	4			0.89	0.93	0.94	0.93	0.91	0.88			0.65	0.68	0.68	0.67	0.66	0.63
	5			1.2	1.2	1.3	1.2	1.2	1.2			0.88	0.91	0.91	0.90	0.88	0.85
	6			1.8	1.9	1.9	1.9	1.8	1.8			1.3	1.4	1.4	1.3	1.3	1.3
	7			2.4	2.5	2.5	2.5	2.4	2.4			1.8	1.8	1.8	1.8	1.8	1.7
	8			3.6	3.7	3.8	3.8	3.7	3.6			2.6	2.7	2.8	2.7	2.7	2.6
9			5.3	5.5	5.5	5.5	5.4	5.2			3.9	4.0	4.0	4.0	3.9	3.7	

Correction for subcooling Δt_{sub}

The evaporator capacity used must be corrected if subcooling deviates from 4 K.

The corrected capacity can be obtained by dividing the evaporator capacity by the correction factor given below.

Note:
Insufficient subcooling can produce flash gas.
Correction factor for subcooling Δt_{sub}

Δt_{sub}	4 K	10 K	15 K	20 K	25 K	30 K	35 K	40 K	45 K	50 K
Correction factor	1.00	1.1	1.2	1.29	1.37	1.46	1.54	1.63	1.7	1.78

Capacity (continued)

Capacity in kW for range B = -60 → -25°C and opening superheat OS = 4 K

R404A/R507

Valve type	Orifice no.	Pressure drop across valve Δp bar								Pressure drop across valve Δp bar							
		2	4	6	8	10	12	14	16	2	4	6	8	10	12	14	16
Evaporating temperature -25°C										Evaporating temperature -30°C							
TU	0	0.30	0.36	0.39	0.40	0.40	0.40	0.39	0.38	0.28	0.33	0.36	0.37	0.37	0.37	0.36	0.35
	1	0.41	0.51	0.55	0.56	0.57	0.56	0.55	0.53	0.36	0.45	0.49	0.51	0.51	0.50	0.48	0.47
	2	0.53	0.66	0.73	0.76	0.77	0.77	0.75	0.73	0.45	0.57	0.62	0.65	0.65	0.65	0.64	0.61
	3	0.74	0.92	1.01	1.06	1.07	1.07	1.04	1.01	0.64	0.79	0.87	0.91	0.91	0.91	0.89	0.86
	4	1.1	1.4	1.5	1.6	1.6	1.6	1.6	1.5	1.0	1.2	1.3	1.3	1.4	1.3	1.3	1.3
	5	1.5	1.8	2.0	2.1	2.1	2.1	2.1	2.0	1.3	1.6	1.7	1.8	1.8	1.8	1.8	1.7
	6	2.2	2.8	3.0	3.2	3.2	3.2	3.1	3.0	1.9	2.4	2.6	2.7	2.7	2.7	2.6	2.6
	7	2.9	3.7	4.1	4.2	4.3	4.3	4.2	4.0	2.5	3.2	3.5	3.6	3.6	3.6	3.5	3.4
	8	4.4	5.5	6.1	6.3	6.4	6.4	6.3	6.1	3.8	4.7	5.2	5.4	5.5	5.4	5.3	5.1
	9	6.5	8.2	9.0	9.4	9.5	9.4	9.2	8.9	5.6	7.0	7.7	8.0	8.1	8.0	7.8	7.5
Evaporating temperature -40°C										Evaporating temperature -50°C							
TU	0		0.28	0.30	0.30	0.31	0.30	0.29	0.28		0.22	0.23	0.24	0.24	0.23	0.22	0.21
	1		0.34	0.37	0.38	0.38	0.38	0.37	0.35		0.24	0.25	0.26	0.26	0.26	0.25	0.24
	2		0.40	0.44	0.45	0.46	0.45	0.44	0.42		0.27	0.30	0.31	0.31	0.30	0.29	0.28
	3		0.57	0.62	0.64	0.64	0.63	0.62	0.59		0.39	0.42	0.43	0.43	0.42	0.41	0.39
	4		0.83	0.91	0.94	0.94	0.93	0.91	0.87		0.57	0.61	0.63	0.63	0.62	0.60	0.57
	5		1.1	1.2	1.3	1.3	1.3	1.2	1.2		0.76	0.82	0.84	0.84	0.83	0.81	0.77
	6		1.7	1.8	1.9	1.9	1.9	1.8	1.8		1.1	1.2	1.3	1.3	1.2	1.2	1.2
	7		2.2	2.4	2.5	2.5	2.5	2.4	2.4		1.5	1.6	1.7	1.7	1.7	1.6	1.5
	8		3.4	3.7	3.8	3.8	3.8	3.7	3.5		2.3	2.5	2.6	2.6	2.5	2.4	2.3
	9		4.9	5.4	5.6	5.6	5.5	5.4	5.2		3.3	3.6	3.7	3.7	3.7	3.5	3.4
Evaporating temperature -60°C																	
TU	0			0.16	0.16	0.16	0.16	0.15	0.15								
	1			0.17	0.17	0.17	0.17	0.16	0.15								
	2			0.19	0.20	0.20	0.19	0.19	0.18								
	3			0.27	0.28	0.28	0.27	0.26	0.25								
	4			0.40	0.41	0.41	0.40	0.38	0.36								
	5			0.53	0.55	0.55	0.53	0.51	0.49								
	6			0.79	0.81	0.81	0.79	0.76	0.73								
	7			1.1	1.1	1.1	1.1	1.0	1.0								
	8			1.6	1.7	1.7	1.6	1.6	1.5								
	9			2.3	2.4	2.4	2.3	2.3	2.1								

Correction for subcooling Δt_{sub}
 The evaporator capacity used must be corrected if subcooling deviates from 4 K. The corrected capacity can be obtained by dividing the evaporator capacity by the correction factor given below.

Note:
 Insufficient subcooling can produce flash gas.

Correction factor for subcooling Δt_{sub}

Δt_{sub}	4 K	10 K	15 K	20 K	25 K	30 K	35 K	40 K	45 K	50 K
Correction factor	1.00	1.1	1.2	1.29	1.37	1.46	1.54	1.63	1.7	1.78

Capacity (continued)

 Capacity in kW for range $N = -40 \rightarrow +10^\circ\text{C}$ and opening superheat $OS = 4\text{ K}$
R407C

Valve type	Orifice no.	Pressure drop across valve Δp bar								Pressure drop across valve Δp bar							
		2	4	6	8	10	12	14	16	2	4	6	8	10	12	14	16
Evaporating temperature +10°C																	
TU	0	0.43	0.54	0.60	0.64	0.67	0.68	0.68	0.68	0.41	0.51	0.56	0.60	0.62	0.63	0.63	0.63
	1	0.63	0.81	0.90	0.96	0.99	1.01	1.02	1.01	0.56	0.73	0.81	0.86	0.89	0.90	0.91	0.90
	2	0.90	1.2	1.4	1.5	1.5	1.6	1.6	1.6	0.8	1.0	1.1	1.2	1.2	1.3	1.3	1.3
	3	1.2	1.6	1.9	2.0	2.1	2.2	2.2	2.2	1.0	1.4	1.5	1.7	1.7	1.8	1.8	1.8
	4	1.9	2.5	2.8	3.1	3.2	3.3	3.3	3.3	1.6	2.1	2.3	2.5	2.6	2.7	2.7	2.7
	5	2.5	3.3	3.8	4.1	4.2	4.4	4.4	4.4	2.1	2.7	3.1	3.3	3.5	3.5	3.6	3.6
	6	3.8	5.0	5.7	6.1	6.4	6.6	6.7	6.7	3.1	4.1	4.6	5.0	5.2	5.3	5.4	5.4
	7	5.0	6.6	7.6	8.2	8.6	8.8	8.9	8.9	4.2	5.4	6.2	6.7	6.9	7.1	7.2	7.2
	8	7.5	9.9	11.2	12.2	12.7	13.0	13.2	13.2	6.3	8.2	9.3	9.9	10.4	10.6	10.7	10.7
9	11.3	14.8	16.9	18.2	19.0	19.5	19.7	19.7	9.3	12.2	13.8	14.8	15.4	15.8	15.9	15.9	
Evaporating temperature 0°C																	
Evaporating temperature -10°C																	
TU	0	0.37	0.46	0.51	0.54	0.55	0.56	0.57	0.56	0.33	0.40	0.44	0.47	0.48	0.49	0.49	0.49
	1	0.48	0.62	0.70	0.74	0.76	0.77	0.77	0.77	0.39	0.50	0.56	0.60	0.62	0.63	0.63	0.63
	2	0.60	0.78	0.88	0.94	0.98	1.00	1.01	1.01	0.47	0.60	0.68	0.72	0.75	0.76	0.77	0.76
	3	0.84	1.1	1.2	1.3	1.4	1.4	1.4	1.4	0.66	0.84	0.95	1.0	1.1	1.1	1.1	1.1
	4	1.3	1.6	1.8	2.0	2.0	2.1	2.1	2.1	0.98	1.3	1.4	1.5	1.6	1.6	1.6	1.6
	5	1.7	2.2	2.4	2.6	2.7	2.8	2.8	2.8	1.3	1.7	1.9	2.0	2.1	2.1	2.1	2.1
	6	2.5	3.2	3.7	3.9	4.1	4.2	4.2	4.2	1.9	2.5	2.8	3.0	3.1	3.2	3.2	3.2
	7	3.4	4.3	4.9	5.2	5.5	5.6	5.6	5.6	2.6	3.3	3.7	4.0	4.1	4.2	4.2	4.2
	8	5.0	6.5	7.4	7.9	8.2	8.4	8.4	8.4	3.9	5.0	5.7	6.0	6.2	6.4	6.4	6.4
9	7.5	9.6	10.9	11.6	12.1	12.3	12.4	12.4	5.8	7.4	8.3	8.9	9.2	9.3	9.4	9.3	
Evaporating temperature -20°C																	
Evaporating temperature -30°C																	
TU	0		0.26	0.29	0.31	0.32	0.32	0.32	0.31			0.29	0.31	0.32	0.32	0.32	0.31
	1		0.38	0.43	0.45	0.47	0.48	0.48	0.47			0.31	0.33	0.34	0.34	0.35	0.34
	2		0.45	0.50	0.53	0.55	0.56	0.56	0.56			0.36	0.38	0.40	0.40	0.40	0.40
	3		0.63	0.71	0.75	0.78	0.79	0.79	0.79			0.51	0.54	0.56	0.56	0.56	0.56
	4		0.93	1.0	1.1	1.1	1.2	1.2	1.2			0.75	0.79	0.81	0.82	0.82	0.82
	5		1.3	1.4	1.5	1.5	1.6	1.6	1.5			1.0	1.1	1.1	1.1	1.1	1.1
	6		1.9	2.1	2.2	2.3	2.3	2.3	2.3			1.5	1.6	1.6	1.6	1.6	1.6
	7		2.5	2.8	3.0	3.1	3.1	3.1	3.1			2.0	2.1	2.2	2.2	2.2	2.2
	8		3.8	4.2	4.5	4.6	4.7	4.7	4.7			3.0	3.2	3.3	3.3	3.3	3.3
9		5.5	6.2	6.5	6.7	6.8	6.9	6.8			4.4	4.7	4.8	4.9	4.9	4.8	
Evaporating temperature -40°C																	

 Correction for subcooling Δt_{sub}

The evaporator capacity used must be corrected if subcooling deviates from 4 K.

The corrected capacity can be obtained by dividing the evaporator capacity by the correction factor given below.

Note:

Insufficient subcooling can produce flash gas.

 Correction factor for subcooling Δt_{sub}

Δt_{sub}	4 K	10 K	15 K	20 K	25 K	30 K	35 K	40 K	45 K	50 K
Correction factor	1.00	1.08	1.14	1.21	1.27	1.33	1.39	1.45	1.51	1.57

Capacity (continued)

Capacity in kW for range B = -60 → -25°C and opening superheat OS = 4 K

R407C

Valve type	Orifice no.	Pressure drop across valve Δp bar								Pressure drop across valve Δp bar							
		2	4	6	8	10	12	14	16	2	4	6	8	10	12	14	16
Evaporating temperature -25°C										Evaporating temperature -30°C							
TU	0	0.34	0.42	0.46	0.49	0.50	0.51	0.51	0.50	0.31	0.38	0.42	0.44	0.45	0.46	0.46	0.46
	1	0.43	0.54	0.61	0.65	0.66	0.67	0.67	0.67	0.37	0.47	0.52	0.56	0.57	0.58	0.59	0.58
	2	0.52	0.67	0.75	0.79	0.82	0.83	0.84	0.83	0.45	0.56	0.63	0.67	0.69	0.70	0.70	0.70
	3	0.73	0.93	1.0	1.1	1.2	1.2	1.2	1.2	0.62	0.79	0.88	0.94	0.97	0.98	0.98	0.98
	4	1.1	1.4	1.5	1.6	1.7	1.7	1.7	1.7	0.92	1.2	1.3	1.4	1.4	1.4	1.5	1.4
	5	1.5	1.8	2.1	2.2	2.3	2.3	2.3	2.3	1.2	1.6	1.7	1.8	1.9	1.9	1.9	1.9
	6	2.2	2.8	3.1	3.3	3.4	3.5	3.5	3.5	1.8	2.3	2.6	2.8	2.9	2.9	2.9	2.9
	7	2.9	3.7	4.1	4.4	4.5	4.6	4.6	4.6	2.5	3.1	3.5	3.7	3.8	3.9	3.9	3.9
	8	4.4	5.6	6.2	6.6	6.8	7.0	7.0	7.0	3.7	4.7	5.3	5.6	5.8	5.8	5.9	5.8
9	6.5	8.2	9.2	9.7	10.1	10.2	10.3	10.2	5.5	6.9	7.7	8.2	8.4	8.6	8.6	8.5	
Evaporating temperature -40°C										Evaporating temperature -50°C							
TU	0	0.24	0.30	0.33	0.35	0.36	0.36	0.36	0.36	0.17	0.22	0.24	0.25	0.26	0.26	0.26	0.26
	1	0.27	0.34	0.37	0.39	0.41	0.41	0.41	0.41	0.18	0.23	0.25	0.27	0.27	0.28	0.28	0.27
	2	0.31	0.39	0.44	0.46	0.47	0.48	0.48	0.48	0.21	0.27	0.29	0.31	0.32	0.32	0.32	0.32
	3	0.44	0.55	0.61	0.65	0.67	0.68	0.68	0.67	0.30	0.37	0.41	0.44	0.45	0.45	0.45	0.45
	4	0.65	0.81	0.90	0.95	0.98	0.99	0.99	0.98	0.44	0.55	0.60	0.63	0.65	0.66	0.66	0.65
	5	0.86	1.1	1.2	1.3	1.3	1.3	1.3	1.3	0.59	0.73	0.81	0.85	0.88	0.88	0.88	0.87
	6	1.3	1.6	1.8	1.9	2.0	2.0	2.0	2.0	0.87	1.1	1.2	1.3	1.3	1.3	1.3	1.3
	7	1.7	2.2	2.4	2.5	2.6	2.7	2.7	2.6	1.2	1.5	1.6	1.7	1.7	1.8	1.8	1.7
	8	2.6	3.3	3.6	3.9	4.0	4.0	4.0	4.0	1.8	2.2	2.4	2.6	2.6	2.7	2.7	2.6
9	3.8	4.8	5.3	5.6	5.8	5.8	5.8	5.8	2.6	3.2	3.5	3.7	3.8	3.9	3.9	3.8	
Evaporating temperature -60°C																	
TU	0	0.12	0.15	0.16	0.18	0.17	0.17	0.17	0.17								
	1	0.12	0.15	0.17	0.18	0.18	0.18	0.18	0.18								
	2	0.14	0.17	0.19	0.20	0.21	0.21	0.21	0.20								
	3	0.20	0.25	0.27	0.29	0.29	0.29	0.29	0.29								
	4	0.29	0.36	0.39	0.41	0.42	0.43	0.42	0.42								
	5	0.39	0.48	0.53	0.56	0.57	0.57	0.57	0.56								
	6	0.58	0.71	0.79	0.83	0.85	0.85	0.85	0.83								
	7	0.78	0.96	1.1	1.1	1.1	1.1	1.1	1.1								
	8	1.2	1.5	1.6	1.7	1.7	1.7	1.7	1.7								
9	1.7	2.1	2.3	2.4	2.5	2.5	2.5	2.5									

Correction for subcooling Δt_{sub}

The evaporator capacity used must be corrected if subcooling deviates from 4 K.

The corrected capacity can be obtained by dividing the evaporator capacity by the correction factor given below.

Note:

Insufficient subcooling can produce flash gas.

Correction factor for subcooling Δt_{sub}

Δt_{sub}	4 K	10 K	15 K	20 K	25 K	30 K	35 K	40 K	45 K	50 K
Correction factor	1.00	1.08	1.14	1.21	1.27	1.33	1.39	1.45	1.51	1.57

Capacity (continued)

 Capacity in kW for range $N = -40 \rightarrow +10^\circ\text{C}$ and opening superheat $OS = 4\text{ K}$
R410A

Valve type	Orifice no.	Pressure drop across valve Δp bar								Pressure drop across valve Δp bar							
		3	6	9	12	15	18	21	24	3	6	9	12	15	18	21	24
Evaporating temperature +10°C										Evaporating temperature 0°C							
TU	0	0.56	0.72	0.80	0.85	0.87	0.88	0.87	0.85	0.56	0.70	0.78	0.83	0.85	0.86	0.85	0.84
	1	0.89	1.13	1.26	1.30	1.37	1.38	1.36	1.33	0.84	1.06	1.18	1.24	1.29	1.30	1.29	1.27
	2	1.45	1.90	2.2	2.3	2.4	2.5	2.4	2.4	1.25	1.64	1.86	1.99	2.1	2.1	2.1	2.1
	3	1.98	2.6	3.0	3.2	3.3	3.3	3.3	3.3	1.72	2.3	2.6	2.7	2.9	2.9	2.9	2.9
	4	3.1	4.1	4.6	4.9	5.1	5.2	5.1	5.0	2.6	3.5	3.9	4.2	4.3	4.4	4.4	4.3
	5	4.1	5.3	6.1	6.5	6.7	6.8	6.8	6.7	3.5	4.6	5.2	5.6	5.8	5.9	5.8	5.8
	6	6.2	8.1	9.2	9.9	10.3	10.5	10.4	10.2	5.3	6.9	7.9	8.4	8.7	8.9	8.9	8.8
	7	8.2	10.7	12.7	13.1	13.6	13.8	13.8	13.5	7.0	9.2	10.4	11.1	11.6	11.8	11.8	11.6
	8	12.1	15.8	18.0	19.3	20.0	20.3	20.2	19.9	10.4	13.7	15.5	16.6	17.2	17.5	17.5	17.2
9	18.3	24.0	27.2	29.1	30.2	30.6	30.5	29.9	15.7	20.5	23.3	24.9	25.8	26.2	26.2	25.7	
Evaporating temperature -10°C										Evaporating temperature -20°C							
TU	0	0.53	0.67	0.74	0.78	0.80	0.81	0.81	0.79	0.60	0.67	0.70	0.72	0.73	0.73	0.72	
	1	0.76	0.96	1.07	1.13	1.16	1.17	1.17	1.15	0.83	0.92	0.97	1.00	1.01	1.00	0.99	
	2	1.04	1.35	1.52	1.63	1.69	1.72	1.72	1.70	1.06	1.20	1.28	1.32	1.34	1.34	1.33	
	3	1.44	1.86	2.1	2.3	2.3	2.4	2.4	2.4	1.48	1.67	1.78	1.84	1.87	1.87	1.85	
	4	2.2	2.8	3.2	3.4	3.5	3.6	3.6	3.5	2.2	2.5	2.7	2.7	2.8	2.8	2.8	
	5	2.9	3.7	4.2	4.5	4.7	4.8	4.8	4.8	3.0	3.3	3.5	3.7	3.7	3.7	3.7	
	6	4.3	5.6	6.4	6.8	7.1	7.2	7.2	7.1	4.4	5.0	5.3	5.5	5.6	5.6	5.5	
	7	5.8	7.5	8.5	9.1	9.4	9.6	9.6	9.5	5.9	6.6	7.1	7.4	7.5	7.5	7.4	
	8	8.6	11.2	12.7	13.6	14.1	14.3	14.3	14.1	8.9	10.0	10.7	11.0	11.2	11.2	11.1	
9	12.9	16.8	19.0	20.3	21.0	21.3	21.3	21.0	13.2	14.8	15.8	16.4	16.6	16.6	16.4		
Evaporating temperature -30°C										Evaporating temperature -40°C							
TU	0		0.52	0.58	0.61	0.63	0.63	0.63	0.62			0.48	0.50	0.52	0.52	0.52	0.51
	1		0.66	0.74	0.79	0.82	0.82	0.82	0.81			0.56	0.59	0.61	0.62	0.62	0.61
	2		0.81	0.90	0.96	1.00	1.01	1.01	1.00			0.66	0.70	0.72	0.73	0.73	0.72
	3		1.13	1.27	1.35	1.40	1.41	1.41	1.40			0.93	0.98	1.02	1.03	1.03	1.01
	4		1.67	1.87	2.0	2.1	2.1	2.1	2.1			1.36	1.45	1.49	1.51	1.50	1.48
	5		2.2	2.5	2.7	2.8	2.8	2.8	2.8			1.82	1.9	2.0	2.0	2.0	2.0
	6		3.3	3.7	4.0	4.1	4.2	4.2	4.1			2.7	2.9	3.0	3.0	3.0	3.0
	7		4.5	5.0	5.4	5.5	5.6	5.6	5.5			3.6	3.9	4.0	4.0	4.0	4.0
	8		6.7	7.6	8.0	8.3	8.4	8.4	8.3			5.5	5.8	6.0	6.1	6.1	6.0
9		9.9	11.1	11.8	12.2	12.4	12.4	12.2			8.1	8.6	8.8	8.9	8.9	8.8	

Correction for subcooling Δt_{sub}

The evaporator capacity used must be corrected if subcooling deviates from 4 K.

The corrected capacity can be obtained by dividing the evaporator capacity by the correction factor given below.

Note:

Insufficient subcooling can produce flash gas.

Correction factor for subcooling Δt_{sub}

Δt_{sub}	4 K	10 K	15 K	20 K	25 K	30 K	35 K	40 K	45 K	50 K
Correction factor	1.00	1.08	1.15	1.21	1.27	1.33	1.39	1.45	1.50	1.56

Design/Function

1. Bulb with capillary tube
2. Thermostatic element with diaphragm
3. Setting spindle for adjustment of static superheat SS
4. Orifice assembly
5. Filter

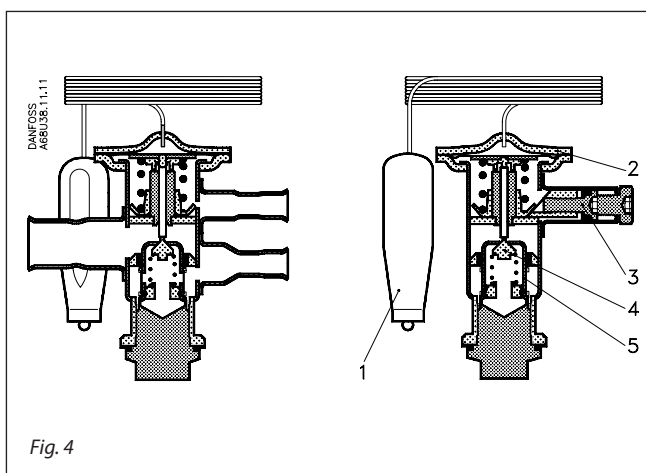

Fig. 4

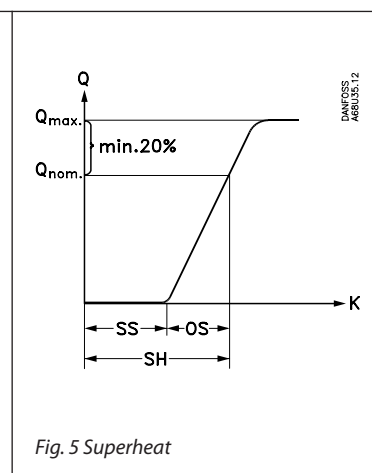

Fig. 5 Superheat

Superheat

See fig. 5

- SS = static superheat
- OS = opening superheat
- SH = SS + OS = total superheat
- Q_{nom} = rated capacity
- Q_{max} = maximum capacity

Static superheat SS can be adjusted with setting spindle 3, see fig. 4.

The standard superheat setting SS is 5 K for valves without MOP and 4 K for valves with MOP (except R507).

The opening superheat OS is 4 K from when opening begins to where the valve gives its rated capacity Q_{nom} .

Example

Static superheat	SS = 5 K
Opening superheat	OS = 4 K
Total superheat	SH = 5 + 4 = 9 K

Dimensions and weight

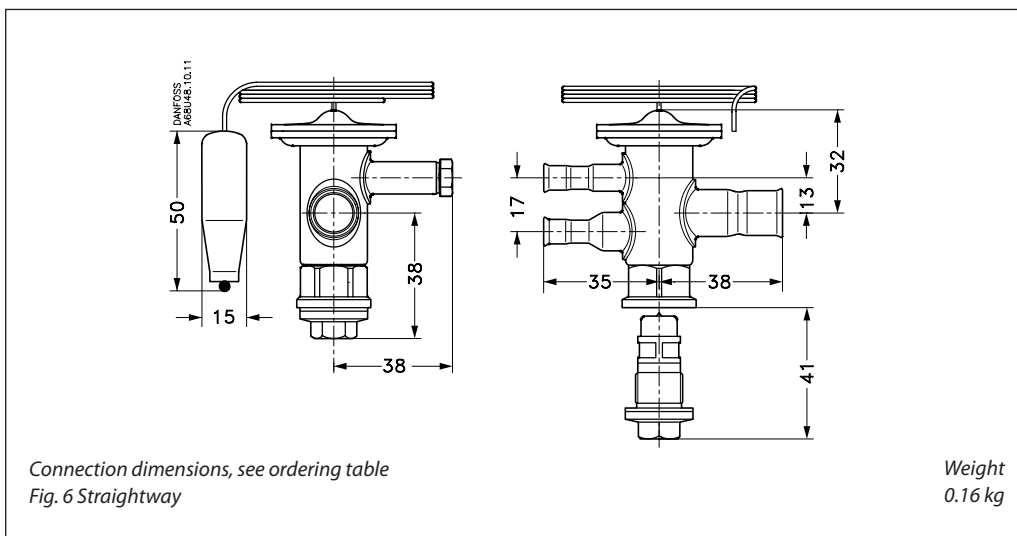

Connection dimensions, see ordering table
Fig. 6 Straightway

Weight
0.16 kg

