

Modulating liquid level regulators direct operated, for low pressure side types SV 4, 5 and 6

Contents

	Page
Introduction.....	3
Features.....	3
Technical data.....	3
Approvals.....	3
Identification.....	3
Materials.....	4
Dimensioning example for SV.....	4
Capacity.....	5
Construction / Function.....	6
Application.....	9
Dimensions and weight.....	10
Ordering.....	11

Introduction



SV 4-6 are for use on the low pressure side as modulating liquid level regulators in refrigeration, freezing and air conditioning systems with ammonia and other common types of refrigerants.

Features

- Reliable function
- Stable regulation, even during momentary load change
- Liquid injection into the float housing or directly into the evaporator through external pipe connection
- Orifice assembly and filter can be replaced without evacuating the float housing
- Can be supplied without float housing for direct installation in the system (special order only)
- Can be used as pilot float for PMLF if mounted with special orifice (diameter Ø2.5 mm)

Technical data

Refrigerants

Can be used for all normal, non-flammable refrigerants, including R717, and non-corrosive gases/liquids - assuming seals of the correct material are used.
Use with flammable hydrocarbons cannot be recommended; please contact Danfoss.

P band

Approx. 35 mm

Max. working pressure

MWP = 28 bar

Max. Δp

SV 4 = 23 bar
SV 5 = 21 bar
SV 6 = 19 bar

Media temperature

-50°C to 120°C

Max. test pressure

MTP = 42 bar

k_v value and diameter for orifice

SV 4: *k_v* = 0.23 m³/hD = 3.0 mm
SV 5: *k_v* = 0.31 m³/hD = 3.5 mm
SV 6: *k_v* = 0.43 m³/hD = 4.0 mm

Approvals



Pressure Equipment Directive (PED)

SV 4, 5 and 6 are approved in accordance with the European standard specified in the Pressure Equipment Directive and are CE marked.
For further details / restrictions - see Installation Instruction

	SV 4, 5 and 6
Classified for	Fluid group I
Category	II

Identification

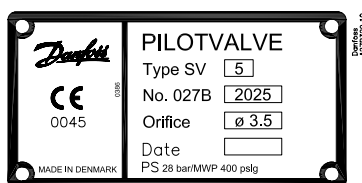

Materials

- Gaskets are non asbestos
- Valve housing made of lowtemperature cast iron, spherical (EN-GJS-400-18-LT)
- Float housing: ST 35.8 DIN 17175 W. no. 1.0305

Dimensioning example for SV

Refrigerant
R717 (NH₃)

Evaporating capacity
 $Q_e = 145 \text{ kW}$

Evaporating temperature
 $t_e = -10^\circ\text{C}$ (~ $p_e = 2.9 \text{ bar abs.}$)

Condensing temperature
 $t_c = +30^\circ\text{C}$ (~ $p_c = 11.7 \text{ bar abs.}$)

Liquid temperature ahead of SV
 $t_l = +20^\circ\text{C}$

Subcooling

$$\Delta t_{\text{sub}} = t_c - t_l = 30^\circ\text{C} - 20^\circ\text{C} = 10 \text{ K}$$

Pressure drop in SV

$$\Delta p = p_c - p_e = 11.7 - 2.9 = 8.8 \text{ bar}$$

Correction factor k for 10 K subcooling
= 0.98

Corrected capacity

$$145 \times 0.98 = 142 \text{ kW}$$

At $t_e = -10^\circ\text{C}$ and $\Delta p = 8 \text{ bar}$ SV 5 yields 147 kW and can therefore be used.

Capacity

The values in the capacity tables are based on a subcooling of 4 K just ahead of the SV valve.
If the subcooling is more or less than 4 K, refer to the following correction factors.

Type	Evaporating temperature t_e °C	Capacity in kW at pressure drop across valve Δp bar							
		0.8	1.2	1.6	2	4	8	12	16

Type	Evaporating temperature t_e °C	Capacity in kW at pressure drop across valve Δp bar							
		0.8	1.2	1.6	2	4	8	12	16

R717 (NH₃)

Type	Evaporating temperature t_e °C	Capacity in kW at pressure drop across valve Δp bar							
		0.8	1.2	1.6	2	4	8	12	16
SV 4	+10	37	45	52	58	79	105	122	134
	0	39	47	54	59	81	107	124	136
	-10	40	48	55	61	82	108	125	137
	-20	41	49	56	62	83	109	125	137
	-30	42	50	57	63	84	109	125	136
	-40	42	51	58	63	84	108	124	135
-50	43	51	58	63	83	107	122	133	
SV 5	+10	51	62	71	78	107	143	166	183
	0	53	64	73	81	110	145	168	185
	-10	54	66	75	83	112	147	170	186
	-20	56	67	76	84	113	148	170	186
	-30	57	68	78	85	114	148	170	185
	-40	58	69	78	86	114	147	168	184
-50	58	69	78	86	113	146	167	182	
SV 6	+10	68	83	95	105	144	191	222	245
	0	71	86	98	108	147	195	226	248
	-10	73	88	101	111	150	197	227	250
	-20	75	90	103	113	152	198	228	250
	-30	76	92	104	115	153	198	227	248
	-40	77	93	105	115	153	197	226	246
-50	78	93	105	115	152	196	223	243	

R22

Type	Evaporating temperature t_e °C	Capacity in kW at pressure drop across valve Δp bar							
		0.8	1.2	1.6	2	4	8	12	16
SV 4	+10	8.5	10.3	11.7	12.9	17.2	21.8	24.1	25.1
	0	8.9	10.7	12.2	13.5	17.8	22.4	24.6	25.7
	-10	9.3	11.2	12.7	14.0	18.3	22.8	25.0	25.9
	-20	9.7	11.6	13.1	14.4	18.7	23.1	25.1	25.9
	-30	9.9	11.8	13.4	14.6	18.9	23.1	25.0	25.7
	-40	10.1	12.1	13.6	14.8	18.9	22.9	24.7	25.3
-50	10.3	12.1	13.6	14.8	18.8	22.6	24.2	24.8	
SV 5	+10	11.6	14.0	15.9	17.6	23.4	29.6	32.7	34.2
	0	12.1	14.6	16.7	18.4	24.3	30.5	33.5	34.9
	-10	12.7	15.2	17.3	19.0	24.9	31.1	34.0	35.3
	-20	13.1	15.7	17.8	19.6	25.4	31.4	34.1	35.3
	-30	13.5	16.1	18.2	19.9	25.7	31.4	34.0	35.0
	-40	13.8	16.4	18.4	20.1	25.7	31.2	33.6	34.5
-50	14.0	16.5	18.5	20.2	25.6	30.7	33.0	33.7	
SV 6	+10	15.5	18.7	21.3	23.6	31.4	39.7	43.9	45.8
	0	16.3	19.6	22.3	24.6	32.6	40.9	45.0	46.8
	-10	17.0	20.4	23.2	25.5	33.5	41.7	45.6	47.3
	-20	17.6	21.1	23.9	26.2	34.1	42.1	45.8	47.3
	-30	18.1	21.6	24.4	26.7	34.5	42.1	45.6	47.0
	-40	18.5	22.0	24.7	27.0	34.5	41.8	45.0	46.2
-50	18.7	22.2	24.8	27.0	34.3	41.2	44.2	45.2	

Correction factors

When dimensioning, multiply the evaporating capacity by the correction factor k , dependent on the subcooling Δt_{sub} just ahead of the valve. The corrected capacity can then be found in the capacity table.

R717 (NH₃)

Δt K	2	4	10	15	20	25	30	35	40	45	50
k	1.01	1.00	0.98	0.96	0.94	0.92	0.91	0.89	0.87	0.86	0.85

R22

Δt K	2	4	10	15	20	25	30	35	40	45	50
k	1.01	1.00	0.96	0.93	0.90	0.87	0.85	0.83	0.80	0.78	0.77

**Construction
Function**

No.	Part	Material	DIN / EN
1	Bottom flange for float valve	Steel	P275NL1 EN10028-3
2	Tube for valve body	Steel	TTST35N DIN17173
3	Connection for float house	Steel	TTST35N DIN17173
4	Top cover for float valve	Steel	P275NL1 EN10028-3
5	Valve housing	Low temperature, cast iron (spherical)	EN-GJS-400-18-LT EN1563
6	Spindle	Stainless steel	
7	Spring	Steel	
8	Sealing ring	Nylon (PA 6)	
9	O-ring	Cloroprene (Neoprene)	
10	Distance ring	Nylon (PA 6)	
11	Packing ring	Nylon (PA 6)	
12	Packing box	Steel	
13	Cap	Steel	
14	Float	Stainless steel	
15	Adjusting ring	Steel	
16	Pin	Steel	
17	Fork for spindle	Steel	
18	Screw	Steel	
19	Locking ring	Steel	
20	Pin	Steel	

Construction
Function
(cont.)

No.	Part	Material	DIN / EN
21	Pin	Steel	
22	Cover with guide	Steel	
23	Screw	Steel	
24	Plug	Steel	
25	Gasket	Non asbestos	
26	Gasket	Aluminium	
27	Valve cone (guide) with pin	Steel / Nylon (PA6)	
28	Valve cone	Teflon (PTFE)	
29	O-ring	Cloroprene (Neoprene)	
30	Nozzle	Teflon (PTFE)	
31	Gasket	Non asbestos	
32	Filter	Steel / Stainless steel	
33	Spring	Steel	
34	Cover for filter	Steel	
35	Gasket	Aluminium	
36	Nipple	Steel	
37	Union nut	Steel	
38	Gasket	Aluminium	
39	Welding nipple	Steel	
40	Locking ring	Steel	
41	Ring	Nylon (PA6)	
42	Pin	Steel	
43	Screw	Stainless steel	A2-70
44	Screw	Stainless steel	A2-70
45	Washer	Steel	
46	Screw	Stainless steel	A2-70

**Construction
Function**
(cont.)

SV 4-6 float valves are for low pressure operation only. They are used for flooded evaporators, where only slight variations in the liquid level can be accepted.

When the liquid level decreases, the float moves downwards. This opens the orifice (pos. 7) and the amount of liquid injected is increased.

The liquid inlet line should be dimensioned in such a way that acceptable liquid velocities and pressure drops are obtained.

This is particularly important when the liquid is only slightly subcooled, since valve capacity is reduced considerably if flashgas occurs in the liquid ahead of the orifice.

The flashgas quantity which occurs on expansion is removed through the balance pipe. On refrigeration plant using fluorinated refrigerants, slight subcooling and a large pressure drop can result in a flashgas quantity of approx. 50% of the injected liquid quantity.

Therefore the pressure drop in this balance pipe must be kept at a minimum, otherwise there is a risk that:

- the liquid level in the evaporator will vary to an unacceptable degree as a function of evaporator load
- the absolute difference between the liquid level of the evaporator and the SV valve

If too large amounts of flash gas are created it is recommended to use the external injection connection or let the liquid expand directly into the surge drum. See application drawings 3 and 4.

See instruction for SV 4 - 6 for:

- Cleaning of strainer
- Change of orifice
- Change of valve plate

Application

The liquid expands into the float housing

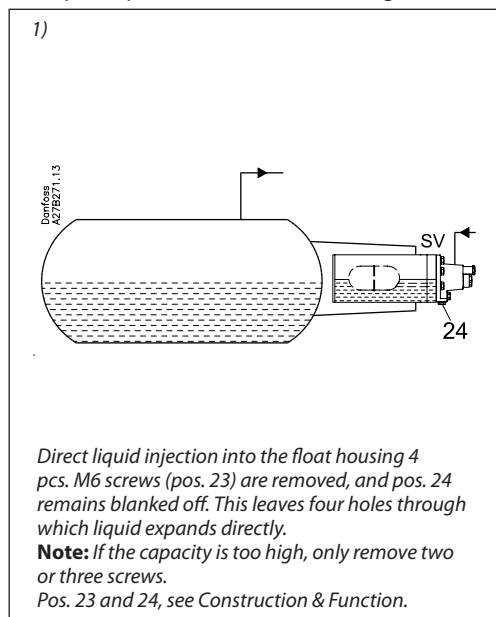

The liquid expands into the float housing

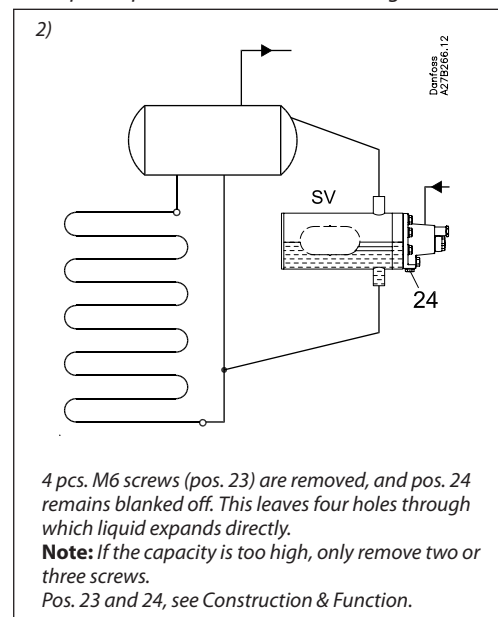

The liquid expands into the evaporator

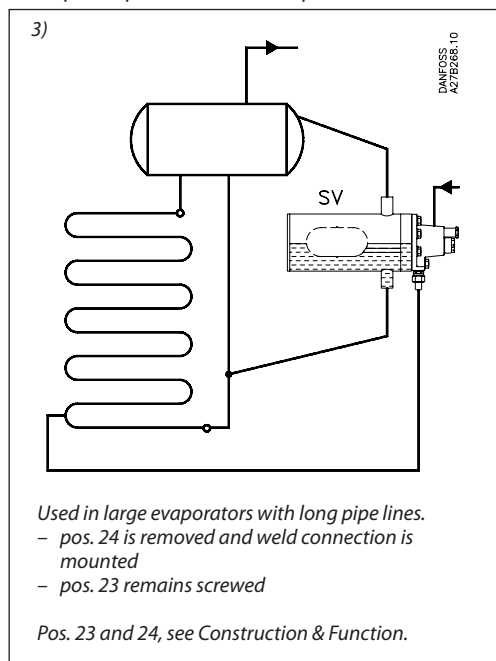

The liquid expands directly into the surge drum

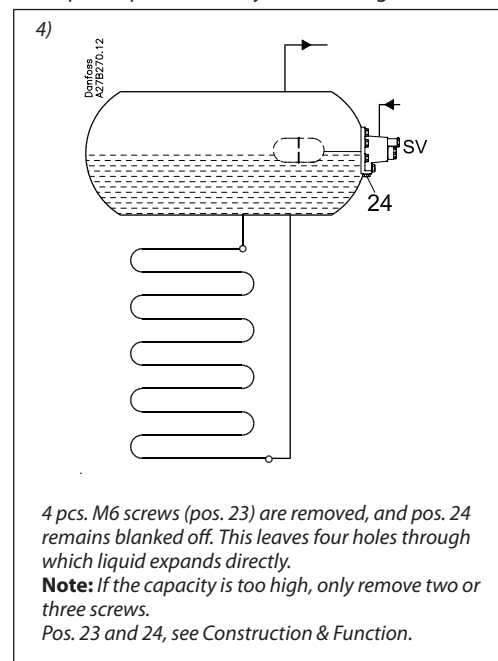

Dimensions and weight

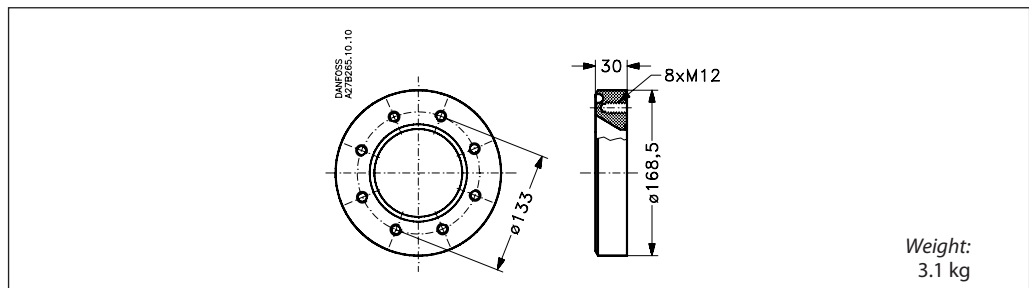
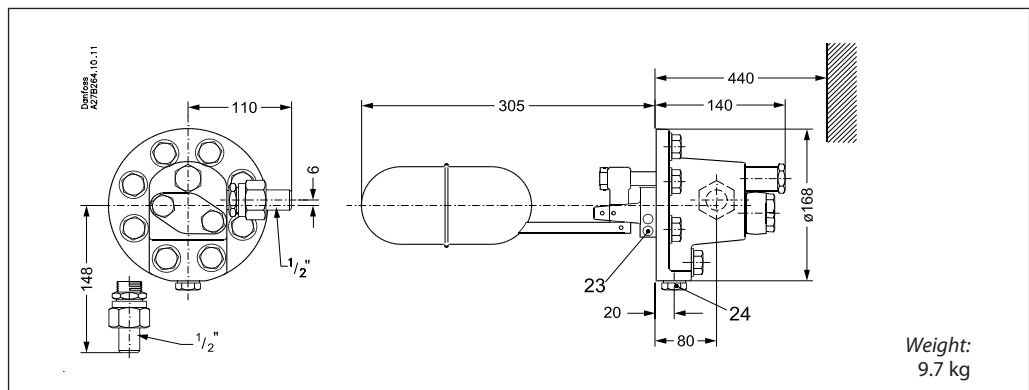
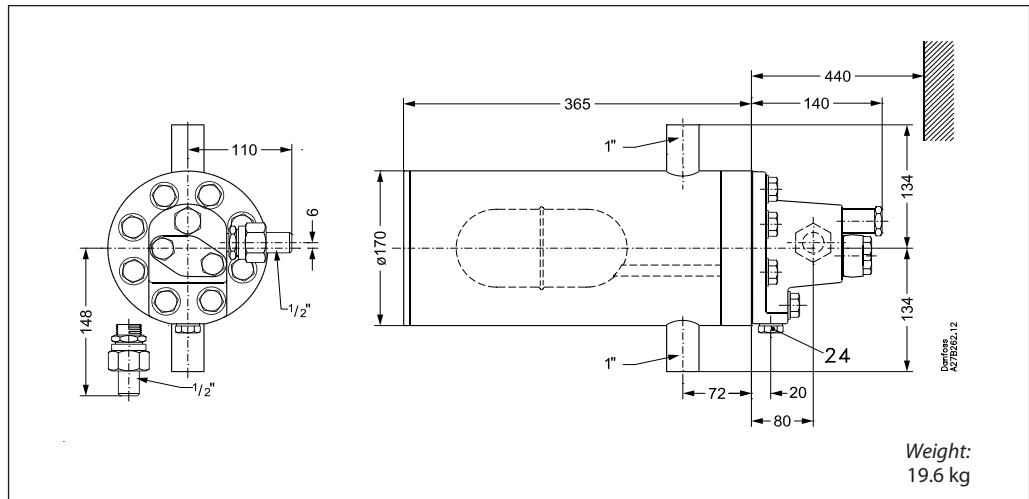

Ordering

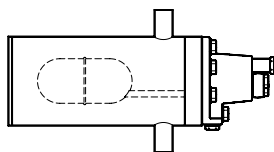

Regulator

The code nos. stated apply to liquid level regulators type SV 4, 5 and 6 with two 1" weld connections for balance tubes and two 1/2" weld joints for liquid and evaporator connections respectively.

Valve type	Orifice diameter	Code no.	Code no. without housing ²⁾	Rated capacity in kW ¹⁾			
				R717	R22	R134a	R404A
SV 4	Ø 3.0 mm	027B2024	027B2014	102	21.0	16.4	15.4
SV 5	Ø 3.5 mm	027B2025	027B2015	138	28.6	22.3	21.0
SV 6	Ø 4.0 mm	027B2026	027B2016	186	38.3	29.9	28.1

¹⁾ The rated capacity refers to the valve capacity at evaporating temperature $t_e = +5^\circ\text{C}$, condensing temp. $t_c = +32^\circ\text{C}$ and liquid temperature $t_l = +28^\circ\text{C}$.

²⁾ Flange for mounting without housing Code no. **027B2027**.

Spare parts and accessories

Smaller orifices for the SV 4 - 6 are available as spare parts and can be mounted in the SV 4 - 6 if smaller capacities are required.

- Seal kit: **027B2070**
- Other spare parts: See spare parts catalogue RK0XG.

Special orifice code no. and rated capacities for SV 4 - 6

Orifice diameter	k_v	Capacities at -10°C evaporating temperature at pressure drop across valve ΔP bar						Code no. ¹⁾
		R717			R22			
		4	7	10	4	7	10	
Ø 1.0 mm	0.026	9	12	13.5	1.6	2.2	2.4	027B2080
Ø 1.5 mm	0.06	21	27	29	3.8	4.9	5.2	027B2081
Ø 2.0 mm	0.10	35	46	50	6.3	8.3	9	027B2082
Ø 2.5 mm	0.16	56	70	81	10	13	15	027B2083
Ø 2.8 mm	0.20	70	87.5	101	12	16	18	027B2084

¹⁾ The code no. includes orifice and all necessary gaskets

Note: The SV 4 - 6 mounted with special orifice diameter Ø2.5 mm is recommended as pilot float valve for the servo-operated level regulators type PMFL for higher capacities.

