



Liquid level glasses, type LLG 185 - 1550

Introduction

LLG are liquid level glasses in ductile steel which meets the strictest requirements on industrial and marine refrigeration installations. The liquid level glasses are offered in 3 different versions:

- with welding nipples (LLG)
- with stop valves equipped with caps (LLG S)
- with stop valves and sight adapter in acrylic glass ready for insulation on site (LLG SF).

The range of liquid level glasses is based on 3 basic liquid level glasses: LLG 185, LLG 335 and LLG 740. The other standard lengths are combined by using variations of basic glass lengths.

LLG produce sufficient flow areas to secure the highest possible degree of synchronous operation, and have a specially hardened reflection glass for quick reading. The front and the base frame are mounted together from the front with countersunk allen screws. This ensures easy insulation on site as well as easy inspection and service, if any.

All liquid level glasses are equipped as standard with a built-in safety system (non return device). If a glass is damaged, the pressure of the refrigerant will activate the safety system and refrigerant loss will be limited to an absolute minimum.

Features

- Refrigerants
Applicable to all common non flammable refrigerants including R717 and non corrosive gases/liquids dependent on sealing material compatibility
- Temperature range
-10/+100°C (-14/+212°F) or
-50/+30°C (-58/+86°F)
- Maximum operating pressure: 25 bar g (363 psi g)
- Equipped with boron silicate glass, hardened by an accurately controlled heat treatment process
- Classification: To get an updated list of certification on the products please contact your local Danfoss Sales Company

Design
Glass

LLG's are equipped with a boronsilicate glass, hardened by an accurately controlled heat treatment process. All glasses are according to DIN 7081.

Gaskets

The glasses are equipped with a special non-asbestos carbon compound gasket which provides superior mechanical characteristics and a long time guarantee against service leakage.

Connectors

LLG 590, LLG 995, LLG 1145 and LLG 1550 are joined together by 2 basic LLG's by means of a connector. The connector holds the two basic glasses together by means of screws and guiding pins, which ensures a rigid construction.

Stop Valves/Nipples

The glasses are connected to the refrigeration system by means of welding nipples or stop valves. Which ever system is used, the nipples or stop valves are screwed into a flange, which is located in the correct position and subsequently tightened with a seal gasket and 4 screws.

Installation

Install the glasses on a bracket using the 4 screws supplied with the glass.

Use the threaded holes on the back of the frame to mount the glass on a bracket (not of Danfoss supply). Always connect the piping after mounting on the bracket. Please note the importance of a minimum of stress in the liquid level glasses from the connected pipes.

Please also make sure that there is sufficient space behind the the liquid level glasses to ensure proper insulation, service and inspection, etc.

For installations below -10°C (+14°F) it is recommended to add the sight adapter to enable reading after insulation has been applied. For installations below -10°C (+14°F) in R717 plants it is recommended to use an oil column as described in the following pages. There will be no formation of bubbles or ice build-up in oilfilled liquid level glasses, which may be the case in the refrigerant-filled glasses.

The liquid sight glasses are designed to withstand high internal pressures. However, the piping system in general should be designed to avoid liquid traps and reduce the risk of hydraulic pressure caused by thermal expansion.

Note:

The LLG liquid level glass can only be placed in CE approved applications with the stop valves in front.

Technical data

- Refrigerants
The liquid level glasses are applicable to all common non flammable refrigerants including R717 and non corrosive gases/liquids dependent on sealing material compatibility.
For further information please see installation instruction for LLG.
Flammable hydrocarbons are not recommended. For further information please contact your local Danfoss Sales Company.
- Temperature range
The liquid level glasses are applicable to the above mentioned refrigerants within the temperature range of:
-10/+100°C (+14/+212°F) for the LLG types with safety system with welding nipples and the LLG S types with safety system with stop valves.
-50/+30°C (-58/+86°F) for the LLG SF types with safety system with stop valves and sight adapter (acrylic glass) and the LLG F types with safety system and sight adapter (acrylic glass).
- Pressure range
All LLG types are designed for:
Max. operating pressure 25 bar g (363 psi g)
Strength test: 50 bar g (725 psi g)
Leakage test: at 25 bar g (363 psi g).

Frostproof liquid level glasses

Example 1
Refrigerant: R717 (ammonia).
Temperature: Recommended for temperatures below -10°C (+14°F).

The principle shown in fig. 1 can be used in connection with low temperature liquid separators or intermediate coolers when the refrigerant is R717 (ammonia).

As the liquid level in the R717 separator varies the oil level will change simultaneously.

Oil Charging

The system is charged with synthetic oil type SHC 226 with a specific weight, differing from that of R717, and (h) must be multiplied by approximately 1.35 (the ratio of density oil to density R717) to calculate H.

Charge the oil vessel (volume approximate 10 litres) to a level just below the lower balancing pipe (A) through the oil charging valve. Close the oil charging valve.

The oil will show in the liquid level glass at a level equal to the level in the oil vessel. When R717 is filled into the separator or intermediate cooler it will enter the oil vessel and press down the oil surface.

The R717 will also rise into the upper balance pipe (B) to a level equal to the level in the separator or intermediate cooler. As the oil surface in the oil vessel is pressed down, the oil will rise into the liquid level glass.

Note:

It is important to use an oil which is not likely to mix with R717. The oil must have a high viscosity index to ensure easy flowing at low temperatures. Mobil SHC 226 of the synthetic polyalphaolefin type has proven suitable for this purpose.

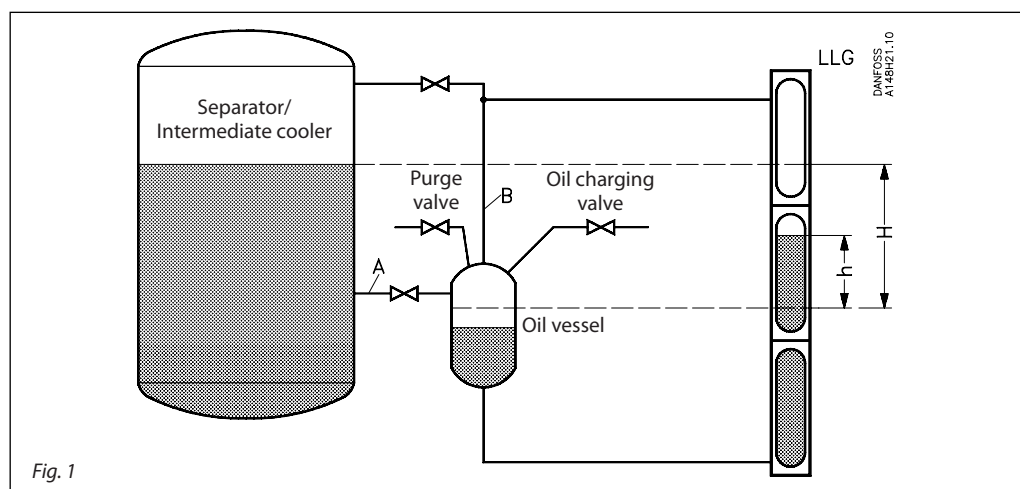

Fig. 1

Frostproof liquid level glasses

Example 2

Refrigerant: R717 (ammonia).
 Temperature: Recommended for temperatures below -10°C (+14°F).

Fig. 2 shows a frostproof liquid level glass for an R717 liquid separator which is placed above ground level. The arrangement is called a Hampsonmeter.

Due to the evaporation taking place in the uninsulated balance pipe (ND 80/3 in.) the pressure in this pipe will be equal to
 $P_1 = P_0 + H \times \rho \times g$.

- P_0 Separator pressure N/m²
- H R717 liquid level (see fig. 2)..... m
- ρ R717 densitykg/m³
- g Acceleration due to gravity 9.81m/s²

Oil Charging

The pressure will act on the oil surface in the oil vessel and cause the oil to rise in the liquid level glasses which are installed in a length of e.g. 2 in. pipe, the top of which is connected to the top of the separator which is at pressure P_0 .

The oil will rise to a level h and H can then be calculated by multiplying h by 1.35 (the ratio of density oil to density R717).

Charge the oil vessel through the oil charging valve to a level of approximately $\frac{3}{4}$ of full level. The level will show in the lower liquid level glass.

Take care that the volume of the oil vessel is sufficient to allow the oil to rise into the liquid level glasses. When the system is operating keep the bypass valve closed.

Note:

It is important to use an oil not likely to mix with R717, and having a high viscosity index to ensure easy oil movements at low temperatures. Mobil SHC 226 of the synthetic polyalphaolefin type has proven suitable for this purpose.

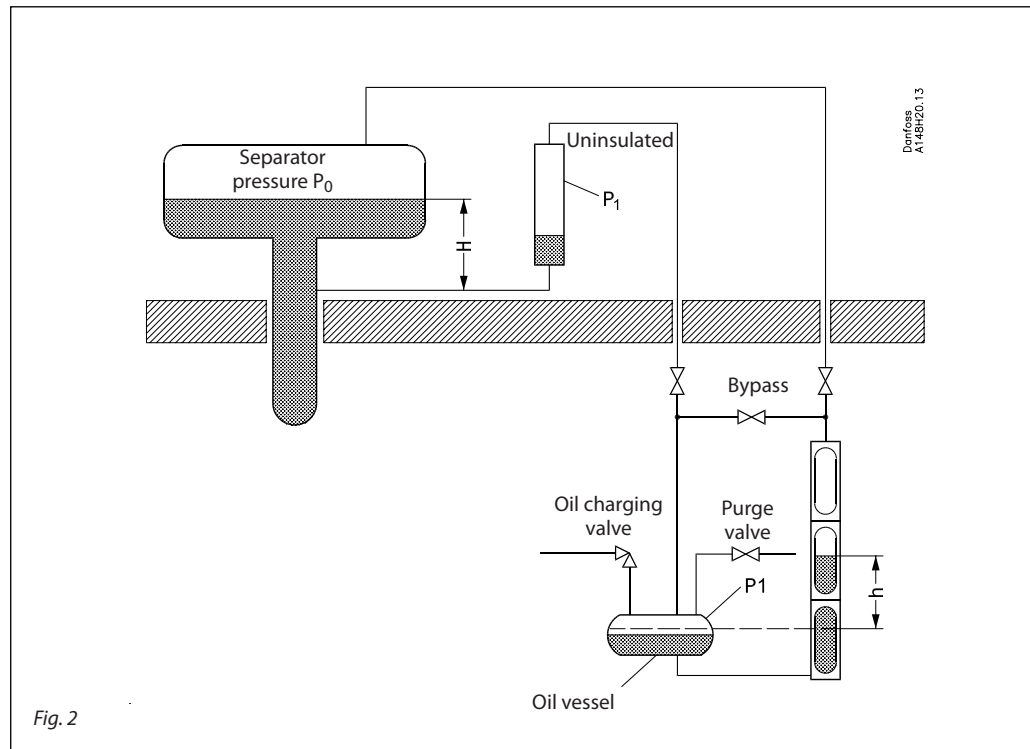

Material specification

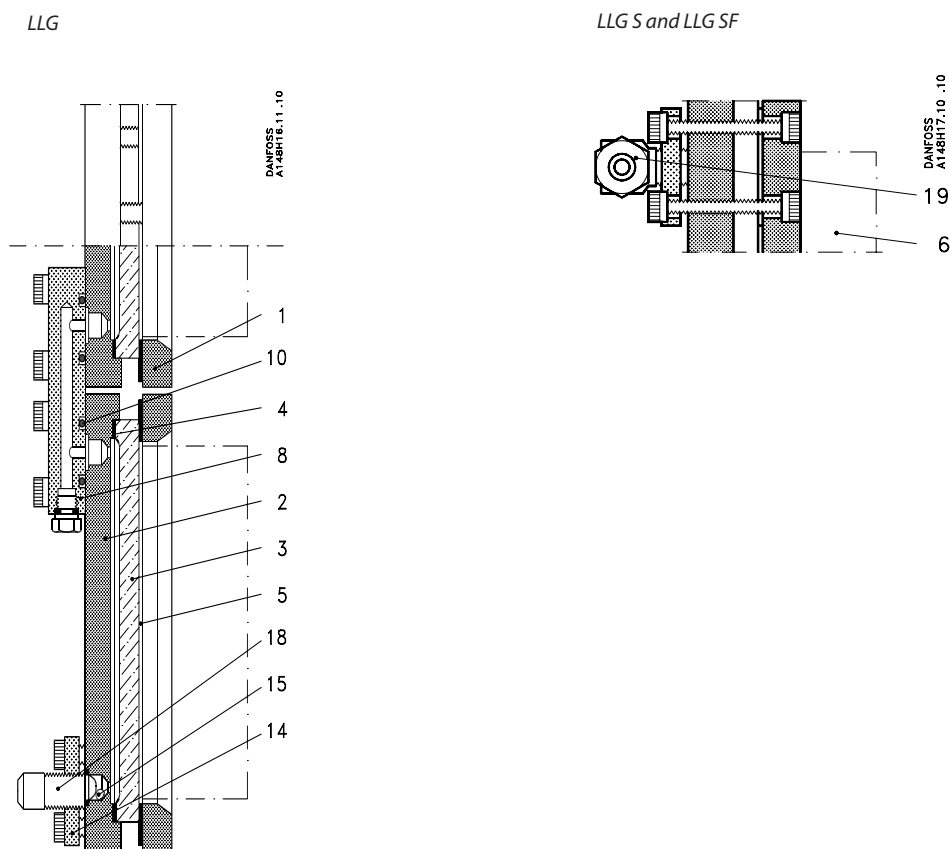

| No. | Part | Material | DIN | ISO | ASTM |
|-----|------------------------------------|-----------------------|-------------------|---------------|----------------|
| 1 | Front frame | Steel | RSt. 37.2, 17 100 | Fe 360 B, 630 | Grade C, A 283 |
| 2 | Back frame | Steel | RSt. 37.2, 17 100 | Fe 360 B, 630 | Grade C, A 283 |
| 3 | Sight glass | Glass | | | |
| 4 | Gasket | Non-asbestos | | | |
| 5 | Protective coating for sight glass | Non-asbestos | | | |
| 6 | Sight adapter | PMMA-acrylic | | | |
| 8 | Connecting piece | Steel | RSt. 37.2, 17 100 | Fe 360 B, 630 | Grade C, A 283 |
| 10 | O-ring | Cloroprene (Neoprene) | | | |
| 14 | Flange | Steel | RSt. 37.2, 17 100 | Fe 360 B, 630 | Grade C, A 283 |
| 15 | Balls | Stainless steel | | | |
| 18 | Welding nipple | Steel | RSt. 37.2, 17 100 | Fe 360 B, 630 | Grade C, A 283 |
| 19 | Stop valve (SNV-ST*) | Steel | | | |

* See technical data for SNV-ST valves.

Dimensions and weights

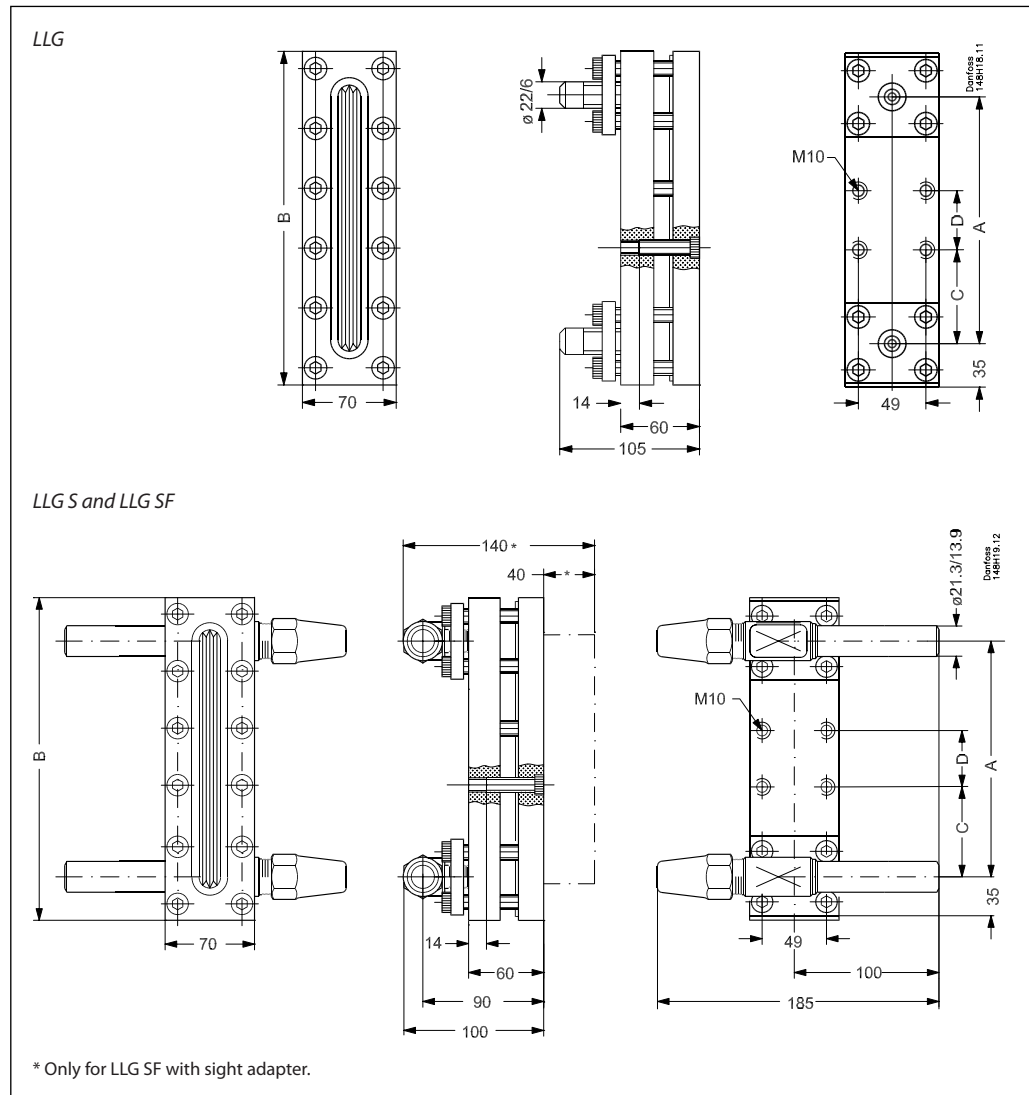

| Type | | A | B | C | D | Weight |
|-----------------------|-----------|------------|-------------|--------------------|--------------------|--|
| <i>LLG 185 - 1550</i> | | | | | | |
| LLG 185 | mm in. | 185 7¼ | 255 10 | 69 2¾ | 48 2 | 4.2 kg ¹⁾ 5.8 kg ²⁾ |
| LLG 335 | mm in. | 335 13¼ | 405 16 | 63 2½ | 42 1¾ | 7.5 kg ¹⁾ 9.2 kg ²⁾ |
| LLG 590 | mm in. | 590 23¼ | 660 26 | 69 + 63 2¾ + 2½ | 48 + 42 2 + 1¾ | 13.2 kg ¹⁾ 15.1 kg ²⁾ |
| LLG 740 | mm in. | 740 29¼ | 810 32 | 63 2½ | 42 1¾ | 16.5 kg ¹⁾ 18.5 kg ²⁾ |
| LLG 995 | mm in. | 995 39¼ | 1065 42 | 69 + 63 2¾ + 2½ | 48 + 42 2 + 1¾ | 22.5 kg ¹⁾ 24.7 kg ²⁾ |
| LLG 1145 | mm in. | 1145 45 | 1215 47¾ | 63 2½ | 42 + 42 1¾ + 1¾ | 25.7 kg ¹⁾ 28.0 kg ²⁾ |
| LLG 1550 | mm in. | 1550 61 | 1620 63¾ | 63 2½ | 42 1¾ | 33.5 kg ¹⁾ 36.1 kg ²⁾ |

¹⁾ Type LLG
²⁾ Type LLG S and LLG SF

Specified weights are approximate values only.

* please note that LLG 740 consist of one back piece and 2 front sight glasses.

Ordering
How to order

The table below is used to identify liquid level glasses required.

Please note that the type codes only serve to identify the liquid level glasses, some of which may not form part of the standard product range.

For further information please contact your local Danfoss Sales Company.

Example for type codes
LLG 740 SF
Type codes

| Valve type | LLG | Liquid Level Glass |
|--------------------|-------------|---|
| Nominal size in mm | 185 | DN 185 |
| | 335 | DN 335 |
| | 590 | DN 590 |
| | 740 | DN 740 |
| | 995 | DN 995 |
| | 1145 | DN 1145 |
| | 1550 | DN 1550 |
| Equipment | - | Safety system and welding nipples |
| | F | Safety system and sight adapter |
| | S | Safety system and stop valves (SNV-ST) |
| | SF | Safety system, stop valves (SNV-ST) and sight adapter |

Liquid level glasses - LLG
With safety system and welding nipples

| Length | | Type | Code no. |
|--------|-----|----------|-----------------|
| mm | in. | | |
| 185 | 7¼ | LLG 185 | 2512+049 |
| 335 | 13¼ | LLG 335 | 2512+050 |
| 590 | 23¼ | LLG 590 | 2512+051 |
| 740 | 29¼ | LLG 740 | 2512+052 |
| 995 | 39¼ | LLG 995 | 2512+053 |
| 1145 | 45 | LLG 1145 | 2512+054 |
| 1550 | 61 | LLG 1550 | 2512+055 |

Liquid level glasses - LLG S
With safety system and stop valves (SNV-ST)

| Length | | Type | Code no. |
|--------|-----|------------|-----------------|
| mm | in. | | |
| 185 | 7¼ | LLG 185 S | 2512+056 |
| 335 | 13¼ | LLG 335 S | 2512+057 |
| 590 | 23¼ | LLG 590 S | 2512+058 |
| 740 | 29¼ | LLG 740 S | 2512+059 |
| 995 | 39¼ | LLG 995 S | 2512+060 |
| 1145 | 45 | LLG 1145 S | 2512+061 |
| 1550 | 61 | LLG 1550 S | 2512+062 |

Liquid level glasses for insulating - LLG F
With safety system and sight adapter

| Length | | Type | Code no. |
|--------|-----|------------|-----------------|
| mm | in. | | |
| 185 | 7¼ | LLG 185 F | 2512+078 |
| 335 | 13¼ | LLG 335 F | 2512+079 |
| 590 | 23¼ | LLG 590 F | 2512+080 |
| 740 | 29¼ | LLG 740 F | 2512+081 |
| 995 | 39¼ | LLG 995 F | 2512+082 |
| 1145 | 45 | LLG 1145 F | 2512+083 |
| 1550 | 61 | LLG 1550 F | 2512+084 |

Liquid level glasses for insulating - LLG SF
With safety system, stop valves (SNV-ST) and sight adapter

| Length | | Type | Code no. |
|--------|-----|-------------|-----------------|
| mm | in. | | |
| 185 | 7¼ | LLG 185 SF | 2512+066 |
| 335 | 13¼ | LLG 335 SF | 2512+067 |
| 590 | 23¼ | LLG 590 SF | 2512+068 |
| 740 | 29¼ | LLG 740 SF | 2512+069 |
| 995 | 39¼ | LLG 995 SF | 2512+070 |
| 1145 | 45 | LLG 1145 SF | 2512+071 |
| 1550 | 61 | LLG 1550 SF | 2512+072 |

Important!

Where products need to be certified according to specific certification societies or where higher pressures are required, the relevant information should be included at the time of order.

