

## Thermostatic liquid level regulators

**Introduction**

TEVA valves are designed for use as liquid level regulators for flooded evaporators, intermediate receivers, and liquid separators.

**Materials**

Valve housing made of GGG40.3

Gaskets are non asbestos

**Technical data**

*Refrigerant*  
R717 (NH<sub>3</sub>). Can also be used for R22.

*Max. working pressure*  
PS= 19 bar

*Temperature of medium*  
-50 → +10°C

*Max. test pressure*  
p' = 28.5 bar

*Capillary tube length*  
5 m

*Voltage and consumption*  
24 V a.c. 10 W

*Connection for external pressure equalization*  
¼ in. (Ø6.5 / Ø 10 mm) weld nipple or 8 mm cutting ring connection.

*Length of electric cable*  
1.5 m

*Approvals*  
DSRK

**Ordering**

Separate thermostatic element with electric heater for TEVA 20 and 85, code no. **068G3255**.

Extra weld bush for bulb, including coupling nut, sealing plug and gasket, code no. **068G0026**.

Separate electric heater for TEVA 20 and 85, code no. **068G0037**.

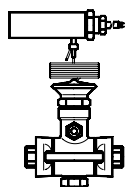

Type and rated capacity in tons (TR)	Rated capacity R717 <sup>1)</sup> (NH <sub>3</sub> ) kW	Connection weld flanges		Code no.		
		Inlet in.	Outlet in.	Ass. regulator with strainer <sup>2)</sup>	Ass. regulator without strainer <sup>2)</sup>	Separate orifice assembly

TEVA 20

TEVA 20-1	3.5	½	½	<b>068G6040</b> + <b>006-0042</b>	<b>068G6040</b>	<b>068G2050</b>
TEVA 20-2	7.0	½	½	<b>068G6041</b> + <b>006-0042</b>	<b>068G6041</b>	<b>068G2051</b>
TEVA 20-3	10.5	½	½	<b>068G6042</b> + <b>006-0042</b>	<b>068G6042</b>	<b>068G2052</b>
TEVA 20-5	17.5	½	½	<b>068G6043</b> + <b>006-0042</b>	<b>068G6043</b>	<b>068G2053</b>
TEVA 20-8	30.0	½	½	<b>068G6044</b> + <b>006-0042</b>	<b>068G6044</b>	<b>068G2054</b>
TEVA 20-12	42.0	½	½	<b>068G6045</b> + <b>006-0042</b>	<b>068G6045</b>	<b>068G2055</b>
TEVA 20-20	70.0	½	½	<b>068G6046</b> + <b>006-0042</b>	<b>068G6046</b>	<b>068G2056</b>

TEVA 85

TEVA 85-33	115	¾	¾	<b>068G6047</b> + <b>006-0048</b>	<b>068G6047</b>	<b>068G2057</b>
TEVA 85-55	195	¾	¾	<b>068G6048</b> + <b>006-0048</b>	<b>068G6048</b>	<b>068G2058</b>
TEVA 85-85	295	¾	¾	<b>068G6049</b> + <b>006-0048</b>	<b>068G6049</b>	<b>068G2059</b>

- 1) The rated capacity is the regulator capacity at -15°C evaporating temperature and +32°C condensing temperature. The capacities are based on 4°C subcooling ahead of the regulator.
  - 2) The strainer is supplied with gaskets, bolts and nuts.
- Note: Subcooling of the liquid in front of the valve is essential for the function of the valve. Lack of subcooling will lead to malfunction of the valve and increase wear on orifice

**Identification**

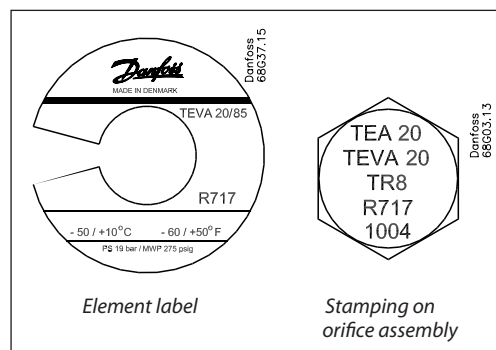

The thermostatic element has a white label on the top. The colour refers to the refrigerant for which the valve is designed: R717 (NH<sub>3</sub>).

The orifice assembly is market with the valve type (TEVA 20) rated capacity (8 TR = 28 kW), refrigerant (R717 = NH<sub>3</sub>), and date marking (1004 = week 10, 2004).

Capacity

The capacities apply to the evaporating temperature range  $-50 \rightarrow +10^{\circ}\text{C}$ .

**R717 (NH<sub>3</sub>)**

Type and rated capacity in tons (TR)	Capacity in kW at pressure drop across regulator <sup>1)</sup>							
	$\Delta p$ bar							
	2	4	6	8	10	12	14	16

**kW**

TEVA 20

TEVA 20 - 1	1.7	2.4	2.9	3.2	3.5	3.7	3.8	4.0
TEVA 20 - 2	3.6	4.9	5.8	6.5	7.0	7.4	7.8	8.1
TEVA 20 - 3	5.5	7.4	8.6	9.7	10.5	10.9	11.5	12.0
TEVA 20 - 5	9.2	12.4	14.8	16.3	17.6	18.5	19.4	20.4
TEVA 20 - 8	14.5	19.8	22.7	25.6	27.9	29.0	30.8	32.0
TEVA 20 - 12	22.1	29.7	33.7	39.0	41.9	44.2	46.5	48.8
TEVA 20 - 20	36.6	50.0	58.0	64.5	70.4	74.4	77.9	81.4

TEVA 85

TEVA 85 - 33	60.5	82.0	96.0	107	116	122	130	135
TEVA 85 - 55	98.9	137	160	179	192	201	213	224
TEVA 85 - 85	150	207	243	276	298	312	329	340

<sup>1)</sup>  $\Delta p$  is generally the pressure difference between condensing and evaporating pressures. In the case of other substantial pressure drops, e.g. due to resistance in long liquid lines, across fittings or difference in height between evaporator and receiver, these pressure drops should be taken into account.  
Capacity tables for TEA and TEAT can also be used as the orifice assembly in the valves are the same.

Design Function

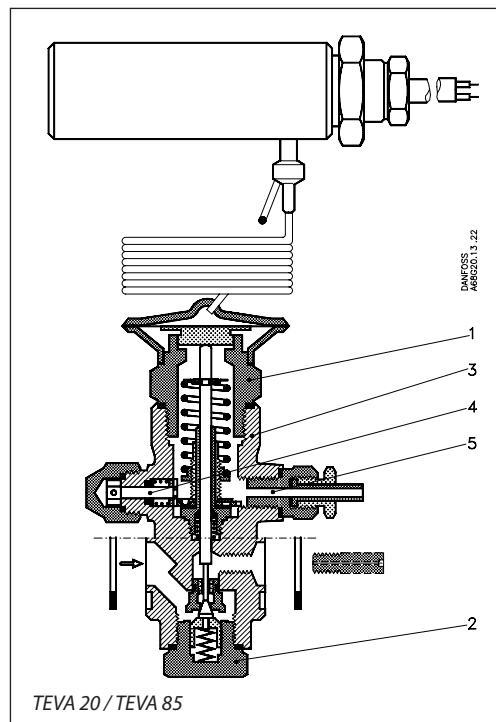

1. Thermostatic element (diaphragm)
2. Orifice assembly
3. Valve body
4. Setting spindle
5. Ext. pressure equalizing connection

Thermostatic liquid level regulator type TEVA consists of a thermostatic expansion valve with a bulb containing a low voltage electric heating element. The purpose of the bulb is to transmit a "superheat signal", to the regulator independent of the temperature of the vapour drawn from the evaporator.

A weld bush is supplied with the bulb for welding into the evaporator or receiver at the required liquid level height. The bulb is fitted in the weld bush.

With the TEVA fitted and the heating element connected, heat is supplied to the bulb. If the liquid level is below the bulb, the heat will not dissipate and pressure across the valve diaphragm will rise. When the liquid level reaches the bulb, the heat in the bulb will dissipate through the refrigerant liquid and the regulator will throttle or shut off completely.

*Note:* The TEVA valve is not able to close completely tight, so a solenoid valve is needed to shut off liquid supply when system stops.

Dimensions and weights

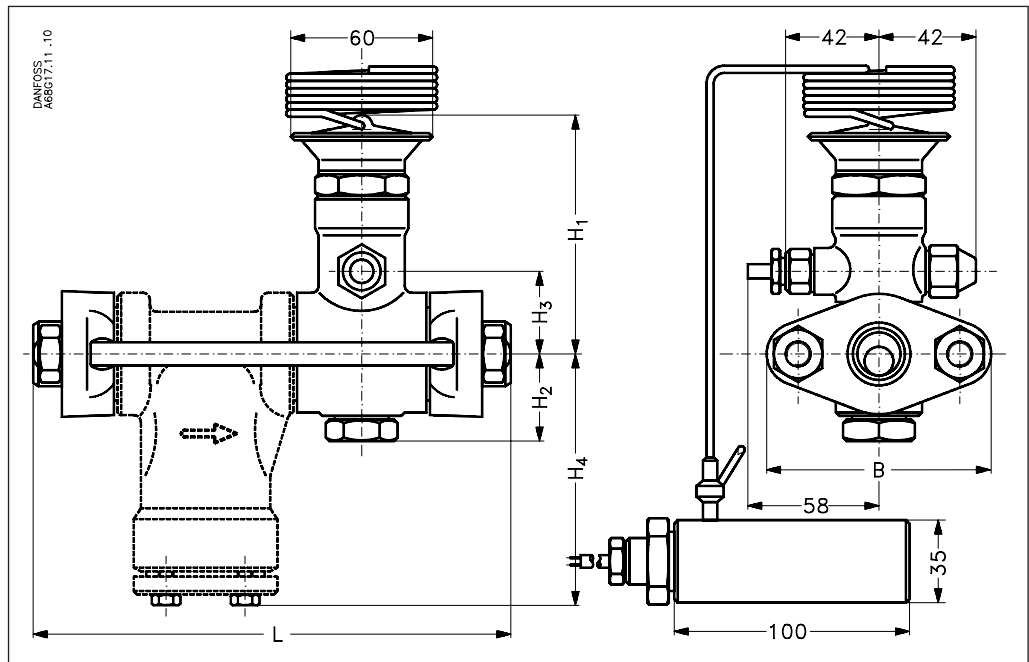

Type	H <sub>1</sub> mm	H <sub>2</sub> mm	H <sub>3</sub> mm	H <sub>4</sub> mm	L		B mm	Weight	
					Without strainer mm	With strainer mm		Without strainer kg	With strainer kg
TEVA 20	94	38	25	96	110	164	80	2.1	3.0
TEVA 85	104	37	35	106	125	199	95	3.0	4.5





