

Safety relief valves, type BSV 8

Contents

	Page
Introduction.....	3
Features.....	3
Technical data.....	4
Design.....	5
Capacity.....	6
Material specification.....	9
Connections.....	10
Dimension and weight.....	10
Ordering.....	11

Introduction



BSV is a standard, back pressure **independent** safety relief valve, especially designed for protection of small components against excessive pressure and as a pilot valve for the pilot operated internal safety valve, type POV.

BSV is an angle-way safety relief valve which can operate with a very high back pressure. The valve is designed to meet the strict quality demands and safety requirements for refrigeration installations, specified by the international classification societies.

As the valve is not dependent on the back pressure, it is recommended for use as an internal safety relief valve. However, the valve can also be used as an external safety relief valve. The spring housing is tightly sealed to avoid refrigerant leakage.

The inlet flow diameter of the BSV 8 is 8.0 mm (⁵/₁₆ in.).

The valves can be delivered with set pressures between 10 and 25 bar g (145 and 363 psi g).

Standard pressure setting valves having "TÜV Pressure Setting Certificate" with each valve are also available.

Features

- Applicable for the refrigerants R717 (ammonia), HFC, HCFC (e.g. R22, R134a, R404a) and other refrigerants dependent on sealing material compatibility.
- Classification: To get an updated list of certification on the products please contact your local Danfoss Sales Company.

Technical data

- **Refrigerants**
Applicable for the refrigerants R717 (ammonia, NH₃), HFC, HCFC (e.g. R22, R134a, R404A) and other refrigerants dependent on sealing material compatibility.
Flammable hydrocarbons are not recommended. For further information please contact your local Danfoss Sales Company.
- **Pressure**
Pressure setting range: 10 - 25 bar g (145 - 363 psi g), For further information please contact your local Danfoss Sales Company.
- **Pressure setting**
The operating pressure of the plant should be at least 15% below the set pressure. This allows a perfect re-seating of the safety relief valve after having been activated.
- **Temperature range for BSV used as an external safety relief valve:**
-30/+100°C (-22/+212°F)
- **Temperature range for BSV used as a pilot valve for POV:**
-50/+100°C (-58/+212°F)

The valves are designed for:
Strength test: 43 bar g (624 psi g)
Leakage safety: 25 bar g (363 psi g)

Special circumstances such as vibrations (which should be avoided) and oscillating pressure may require an increased difference between the operational pressure and the closing pressure.

Pressure Equipment Directive (PED)

The BSV-valves are approved in accordance with the European standard specified in the Pressure Equipment Directive and are CE marked.
For further details / restrictions - see Installation Instruction

	BSV 8
Nominal bore	8 mm (0.315 in.)
Classified for	Fluid group I
Category	IV

Design

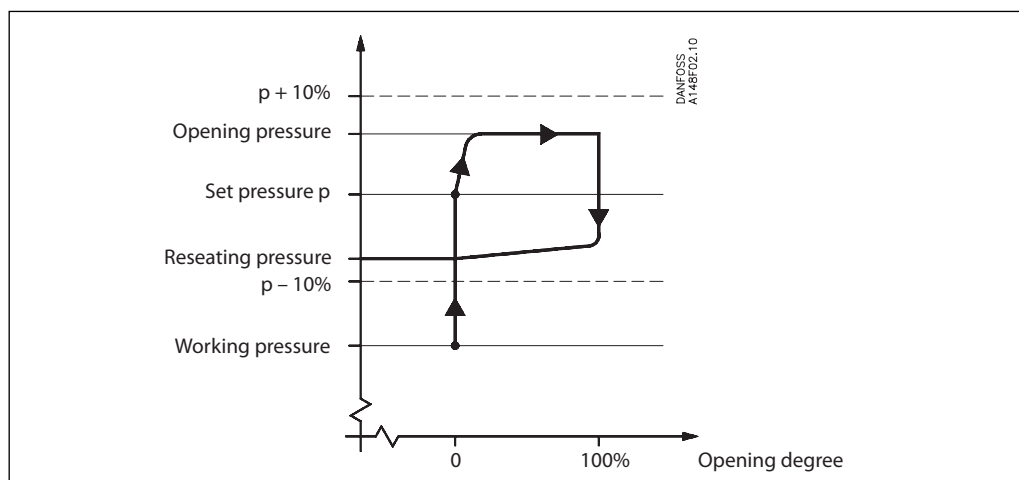

BSV is designed as a standard safety relief valve (DIN 3320) which are recommended for refrigeration plants. On a rise in pressure above the set pressure, the safety relief valve will initially start opening slightly, to minimise the outlet of refrigerant. If the pressure continues to increase, the valve will open fully. The safety relief valve will be fully open before the pressure is 10% higher than set pressure, and fully closed before the pressure is 10% below set pressure.

The valve is recommended as an internal safety relief valve because its function is independent of the back pressure. The valve can also be used as an external safety relief valve.

Connections

Available with the following connections:

- Outside pipe thread T (ISO 228/1)

Housing

Made of special steel approved for low temperature application. Spindle and seat are made of stainless steel, to ensure precise operation even during extraordinary conditions. The gasket of the valve cone is made of a special neoprene compound.

Installation

To ensure exact operation of the safety relief valve it should be installed with the spring housing upwards. If the valve is mounted as an internal safety relief valve without any demand for exact opening pressure, the valve may be fitted with the spring housing in other positions. When the valve is mounted, it is important to avoid the influence of static, dynamic and thermal stress.

A very precise technique has been applied for the production of the seal. However, this seal can still be damaged, if dirt is blown from the pipe system into the valve.

Re-calibration/servicing

In certain countries the authorities demand that the valves are readjusted at least once a year (see local rules).

Control/Identification

After adjustment of the set pressure at Danfoss, the valves are sealed. For that reason Danfoss can only guarantee correct operation, as long as the seal remains unbroken.

All valves are provided with a metal plate with the following information:

- Flow diameter
- Set pressure
- Date of production
- Production number
- Type approved code.

Transport/Handling

The valves are fitted with special protection covers and packed in purpose made transportation cartons. It is important that the cover remains fitted around the valve until it is installed.

To ensure the exact and precise operation of the valve it must be handled with care.

Capacity

The design and construction of the safety relief valve has been tested and approved by TÜV. This test comprises control of the function of the valve as well as measuring of the capacity, which is the basis of the curves and tables on the following pages. The values in the table are based on saturated gas.

If e.g. back pressure or superheated gas have to be taken into consideration, the formulas or the Danfoss computation program (DIRcalc™) can be used.

Table 1.

Valve	Nominal size		Flow diameter d ₀	Flow area A ₀	De-rated, certified coefficient of discharge K _{dr}
	Inlet	Outlet			
BSV 8	15 mm 1/2 in.	20 mm 3/4 in.	8 mm 0.315 in.	50 mm ² 0.078 in ²	0.46

The discharge capacity of the safety relief valves are based on (ISO 4126-1/EN 1268-1 / prEN 1313 6 (1998)).

$$q_m = 0.2883 \times C \times A_0 \times K_{dr} \times K_b \times \sqrt{\frac{p}{v}}$$

q_m Discharge capacity (kg/h)

C Discharge function depending of the actual refrigerant (κ) see table 2.

A₀ Flow area of the safety relief valve (mm²).

K_{dr} De-rated coefficient of discharge (K_{dr} = K_d × 0.9), (the K_{dr} is certified by TÜV) see table 1.

K_b Correction factor for sub-critical flow. (-)

K_b = 1.0 when the back pressure is lower than approx. 0.5 × relieving pressure (P_b < 0.5 × p).

v Specific volume of the vapour. (m³/kg)

p_{set} Set pressure, the predetermined pressure at which a pressure relief valve under operation starts to open (p_{set} is indicated on the metal plate on the safety relief valve). (bar g)

p_{atm} Atmospheric pressure. (1 bar)

p Relieving pressure, p = p_{set} × 1.1 + P_{atm} (bar a)

For further details see the above mentioned ISO or EN standards.

Important!

For back pressure higher than 0.5 × p, the Danfoss computer program (DIRcalc™) or the above mentioned standard must be used when calculating the capacity.

Table 2. Properties of Refrigerants

Refrigerant	Isentropic exponent κ	Discharge function C
R22	1.17	2.54
R134a	1.12	2.50
R404A	1.12	2.49
R410A	1.17	2.54
R717 (Ammonia)	1.31	2.64
R44 (CO ₂)	1.30	2.63
Air	1.40	2.70

Capacity

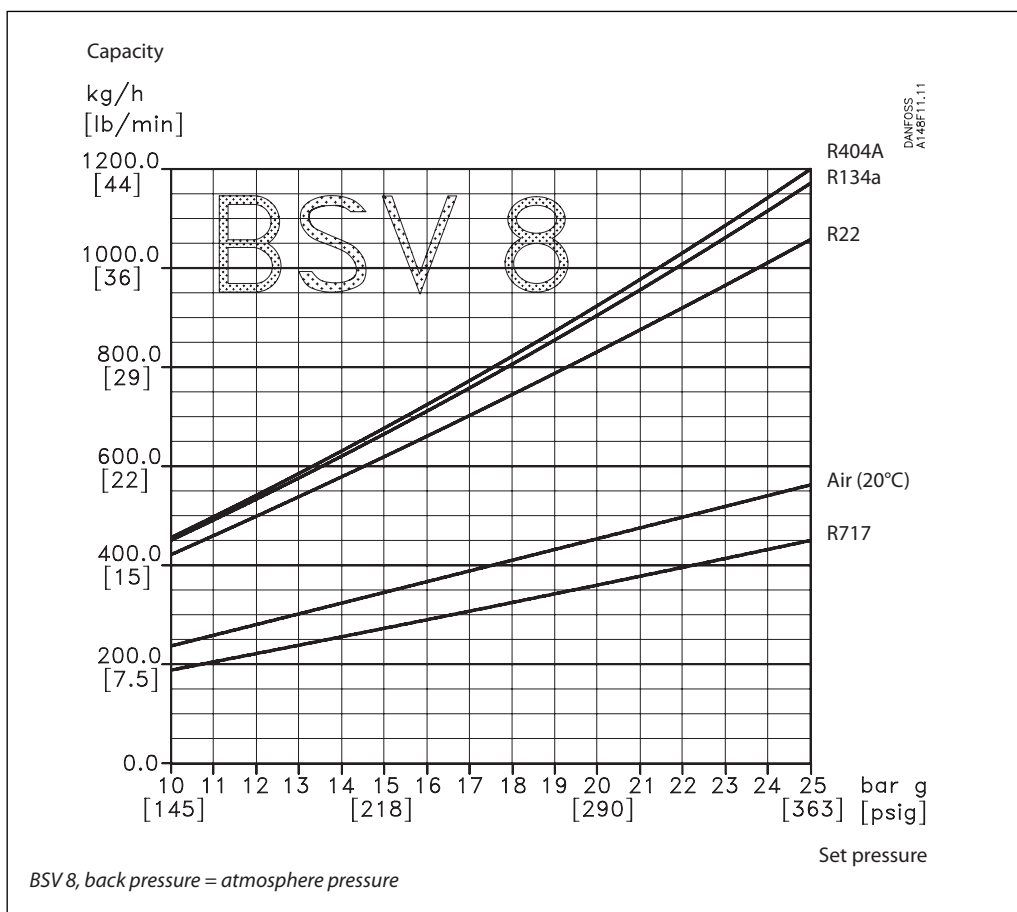

Capacity

Set pressure	R22	R134a	R404A	R717	Air (20°C)
--------------	-----	-------	-------	------	------------

BSV 8, back pressure = atmosphere pressure

13 bar g	kg/h	540	575	590	240	300
189 psi g	lb/min	19.9	21.2	21.6	8.7	11.1
18 bar g	kg/h	745	810	825	325	410
261 psi g	lb/min	27.5	29.7	30.3	11.9	15.0
21 bar g	kg/h	875	955	970	375	475
305 psi g	lb/min	32.2	35.1	35.7	13.8	17.4
25 bar g	kg/h	1060	1175	1200	445	560
363 psi g	lb/min	38.9	43.2	44.0	16.4	20.6

The capacity calculation is based on ISO 4126 - 1 / EN 1268 - 1 / prEN 13136 (1998)

Capacity

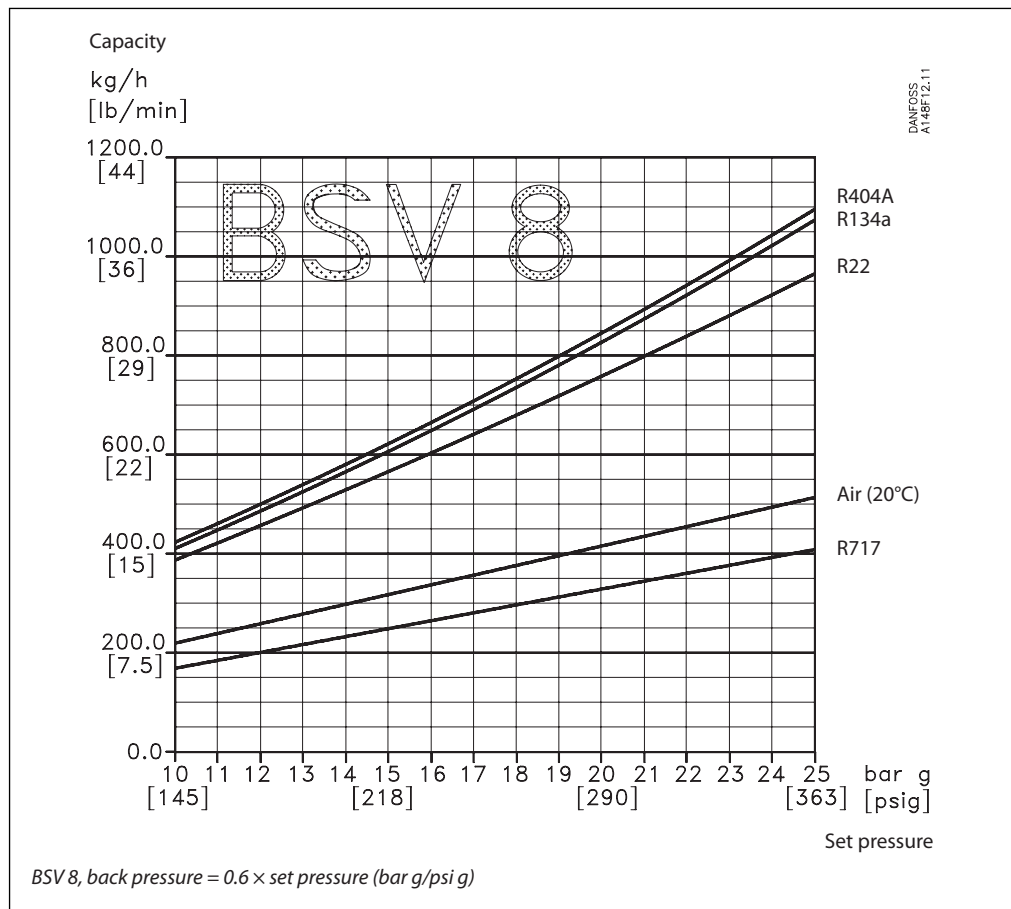

Capacity

Set pressure	R22	R134a	R404A	R717	Air (20°C)
--------------	-----	-------	-------	------	------------

BSV 8, back pressure = 0.6 x set pressure (bar g/psi g)

13 bar g	kg/h	495	525	535	215	275
189 psi g	lb/min	18.2	19.4	19.7	8.0	10.1
18 bar g	kg/h	680	740	755	295	375
261 psi g	lb/min	25.1	27.1	27.7	10.9	13.7
21 bar g	kg/h	800	875	885	345	435
305 psi g	lb/min	29.4	32.1	32.6	12.6	15.9
25 bar g	kg/h	965	1075	1095	410	510
363 psi g	lb/min	35.5	39.4	40.2	15.0	18.8

The capacity calculation is based on ISO 4126 - 1 / EN 1268 - 1 / prEN 13136 (1998)

Material specification

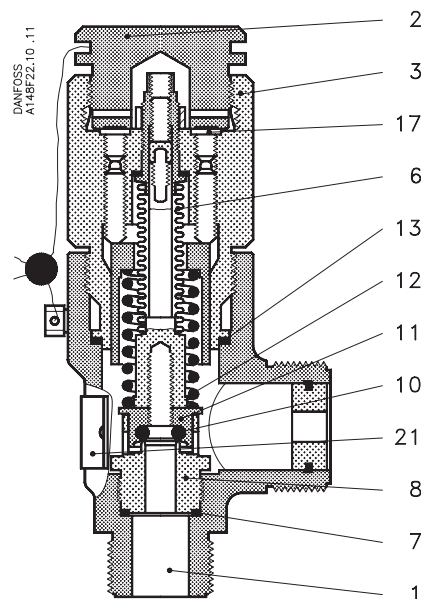

No.	Part	Material	DIN	ISO	ASTM
1	Housing	Steel	TT St 35 N/V, 17173	TW 6, 2604/3-75	Grade 1, A333, A334 A350 LF2 ¹⁾
2	Threaded plug	Steel	9S Mn28, 1651 - 88	11S Mn28 630/9 - 88	1213 SAE J 403
3	Valve top	Steel	St. 37.2, 1652 - 2 - 90	Fe 360 B, 660 - 80	Grade C, A 283
6	Bellow	Stainless steel			
7	Gasket	Aluminium			
8	Valve seat	Stainless steel			
10	O-ring	Cloroprene (Neoprene)			
11	Valve cone	Steel			
12	Spring	Steel	Class C, 17223-1-84		A 679SAE J 403
13	Gasket	Aluminium			
17	Gasket	Aluminium			
21	Marking label	Aluminium			

¹⁾ Alternative material

Connections

T

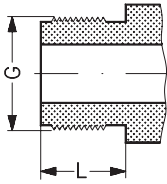

DANFOSS
A148B21-11

Size mm	Size in.	Inlet	Outlet		L mm	L in.		
---------	----------	-------	--------	--	------	-------	--	--

T outside pipe thread, (ISO 228/1)

8	5/16	G 3/4	G 1		17	0.67		
---	------	-------	-----	--	----	------	--	--

Dimension and weight

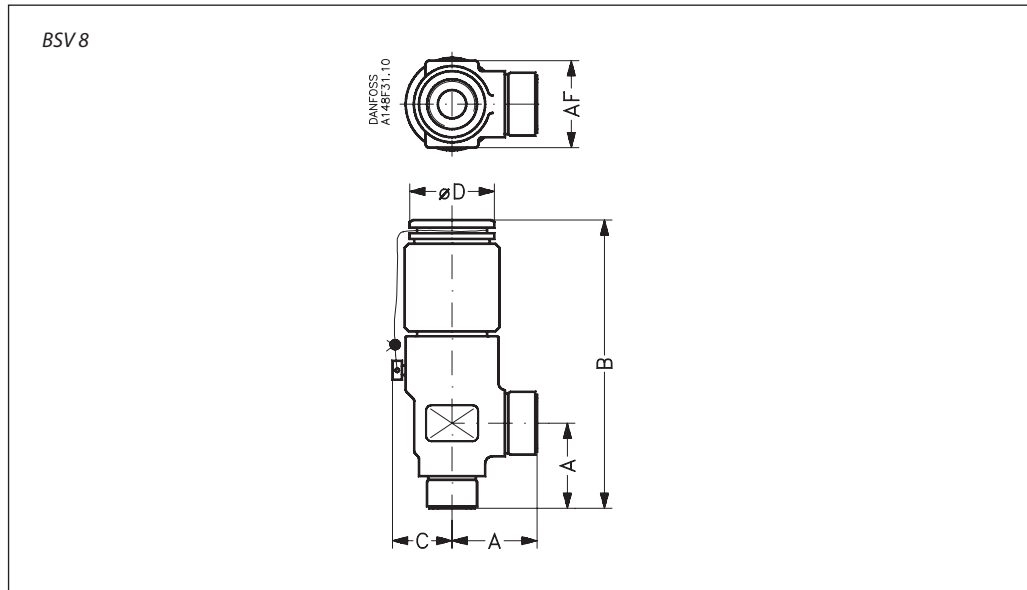

Valve size		A	B	C		∅D		AF	Weight
------------	--	---	---	---	--	----	--	----	--------

BSV 8, with threaded connections ISO 228/1 pipe threads

BSV 8 (5/16 in.)	mm	45	150	32		50		46	1.5 kg
	in.	1.77	5.91	1.26		1.97		1.81	3.3 lb

Specified weights are approximate values only.

Ordering
How to order

The table below is used to identify the valve required.

Please note that the type codes only serve to identify the valves, some of which may not form part of the standard product range. For further information please contact your local Danfoss Sales Company.

Example for type codes

BSV 8 T 211

Type codes

Valve type	BSV	Back pressure independent safety valve
Nominal size in mm	8	DN 8
Connections	T	Outside threaded connections: ISO 228/1 Pipe thread - Fittings for connections must be ordered separately - Fittings for pilot operation - The welding fittings for single mounted safety relief valve must be ordered separately
Pressure setting	210 211 212 213 214 215 216 217 218 219 220 221 222 223 224 225 310 311 312 313 314 315 316 317 318 319 320 321 322 323 324 325	<i>Standard pressure setting: 2××</i> 10 bar g (145 psi g) 11 bar g (160 psi g) 12 bar g (174 psi g) 13 bar g (189 psi g) 14 bar g (203 psi g) 15 bar g (218 psi g) 16 bar g (232 psi g) 17 bar g (247 psi g) 18 bar g (261 psi g) 19 bar g (276 psi g) 20 bar g (290 psi g) 21 bar g (305 psi g) 22 bar g (319 psi g) 23 bar g (334 psi g) 24 bar g (348 psi g) 25 bar g (363 psi g) <i>Standard pressure setting with TÜV certificate: 3××</i> 10 bar g (145 psi g) 11 bar g (160 psi g) 12 bar g (174 psi g) 13 bar g (188 psi g) 14 bar g (203 psi g) 15 bar g (218 psi g) 16 bar g (232 psi g) 17 bar g (247 psi g) 18 bar g (261 psi g) 19 bar g (276 psi g) 20 bar g (290 psi g) 21 bar g (304 psi g) 22 bar g (319 psi g) 23 bar g (334 psi g) 24 bar g (348 psi g) 25 bar g (362 psi g)

Important!

Where products need to be certified according to specific certification societies, the relevant information should be included at the time of order.

Certified BSV valves with standard set pressure

Size		Construction and test facilities are approved by TÜV		
mm	in.	Type	bar g (psi g)	Part No.
8	$\frac{5}{16}$	BSV8 T 210	10 (145)	2416+200
8	$\frac{5}{16}$	BSV8 T 211	11 (160)	2416+309
8	$\frac{5}{16}$	BSV8 T 212	12 (174)	2416+310
8	$\frac{5}{16}$	BSV8 T 213	13 (189)	2416+201
8	$\frac{5}{16}$	BSV8 T 214	14 (203)	2416+311
8	$\frac{5}{16}$	BSV8 T 215	15 (218)	2416+312
8	$\frac{5}{16}$	BSV8 T 216	16 (232)	2416+221
8	$\frac{5}{16}$	BSV8 T 217	17 (247)	2416+313
8	$\frac{5}{16}$	BSV8 T 218	18 (261)	2416+202
8	$\frac{5}{16}$	BSV8 T 219	19 (276)	2416+225
8	$\frac{5}{16}$	BSV8 T 220	20 (290)	2416+203
8	$\frac{5}{16}$	BSV8 T 221	21 (305)	2416+204
8	$\frac{5}{16}$	BSV8 T 222	22 (319)	2416+224
8	$\frac{5}{16}$	BSV8 T 223	23 (334)	2416+314
8	$\frac{5}{16}$	BSV8 T 224	24 (348)	2416+315
8	$\frac{5}{16}$	BSV8 T 225	25 (363)	2416+205

Certified BSV valves with standard set pressure and TÜV pressure setting certificate with each valve

Size		Each valve is certified by a representative from TÜV		
mm	in.	Type	bar g (psi g)	Part No.
8	$\frac{5}{16}$	BSV8 T 310	10 (145)	2416+316
8	$\frac{5}{16}$	BSV8 T 311	11 (160)	2416+317
8	$\frac{5}{16}$	BSV8 T 312	12 (174)	2416+318
8	$\frac{5}{16}$	BSV8 T 313	13 (189)	2416+206
8	$\frac{5}{16}$	BSV8 T 314	14 (203)	2416+319
8	$\frac{5}{16}$	BSV8 T 315	15 (218)	2416+320
8	$\frac{5}{16}$	BSV8 T 316	16 (232)	2416+222
8	$\frac{5}{16}$	BSV8 T 317	17 (247)	2416+321
8	$\frac{5}{16}$	BSV8 T 318	18 (261)	2416+207
8	$\frac{5}{16}$	BSV8 T 319	19 (276)	2416+322
8	$\frac{5}{16}$	BSV8 T 320	20 (290)	2416+208
8	$\frac{5}{16}$	BSV8 T 321	21 (305)	2416+209
8	$\frac{5}{16}$	BSV8 T 322	22 (319)	2416+210
8	$\frac{5}{16}$	BSV8 T 323	23 (334)	2416+323
8	$\frac{5}{16}$	BSV8 T 324	24 (348)	2416+324
8	$\frac{5}{16}$	BSV8 T 325	25 (363)	2416+211