

## Type 2:

# Installation instructions, Wingrail, round outlet equipped with Fasttrack

### Installation instructions

Inspect your shipment carefully matching contents with packing slip information. Make sure everything is present. Note any missing or damaged pieces listed on the Bill of Lading before accepting the shipment in order to facilitate a claim for shipping damage.

Euro Air products are for use only as described in the brochure and catalogue published by Euro Air. All other use is without liability for Euro Air A/S. If you have any questions about Euro Air products please contact your local Euro Air office.

### Special tips:

1. All outlet components are given a position number which can be found on the washing label (washing label is sewn onto the inside of the outlet, one present at all joints). **When mounting, always connect continuous numbers, example: Pos. 1.1 => Pos. 1.2 => Pos. 1.2 => Pos. 1.3 (by identical pieces, the components are given the same position number).**
2. To hide the clamp you can wrap the collar piece over the clamp
3. When the unit is turned on, gently pull the sock on one end to straighten out any wrinkles, and fix the clip at the end of the outlet to the suspension wire, using the included wire locknut.

## Type 2:

# Montage vejledning, Wingrail, rund posekanal med Fasttrack

### Montage vejledning

Inspicer forsendelse omhyggeligt, indhold i kasser skal svare nøjagtigt til vedlagt pakkeliste. Såfremt enkelte dele er blevet beskadiget under transporten, skal dette noteres på fragtbrev før forsendelse accepteres.

Anvendelse af Euro Air's produkter, begrænser sig til de i brochure og katalog nævnte områder. Al anden anvendelse sker på eget ansvar og absolut uden ansvar for Euro Air.

Ved tvivlsspørgsmål, henvend Dem da altid til Euro Air's hovedkontor i Rødning.

### Specielle tips:

1. Alle delkomponenter til posen er tildelt et individuelt positionsnummer. Dette nummer kan findes på indvendig side af posen, på det isyede vaskemærke. **Ved montage monteres altid efter fortløbende numre, eksempel: Pos. 1.1 => Pos. 1.2 => Pos. 1.2 => Pos. 1.3 (såfremt flere delkomponenter er identiske har disse identiske positionsnumre).**
2. Buk posekanal rundt om spændebånd så dette skjules
3. Efter opstart træk da forsigtigt i ende af posekanal så eventuelle rynker udglattes, og fiksér sidste clips på montage wiren vha. medleverede wirelås.

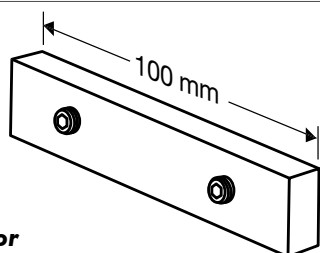
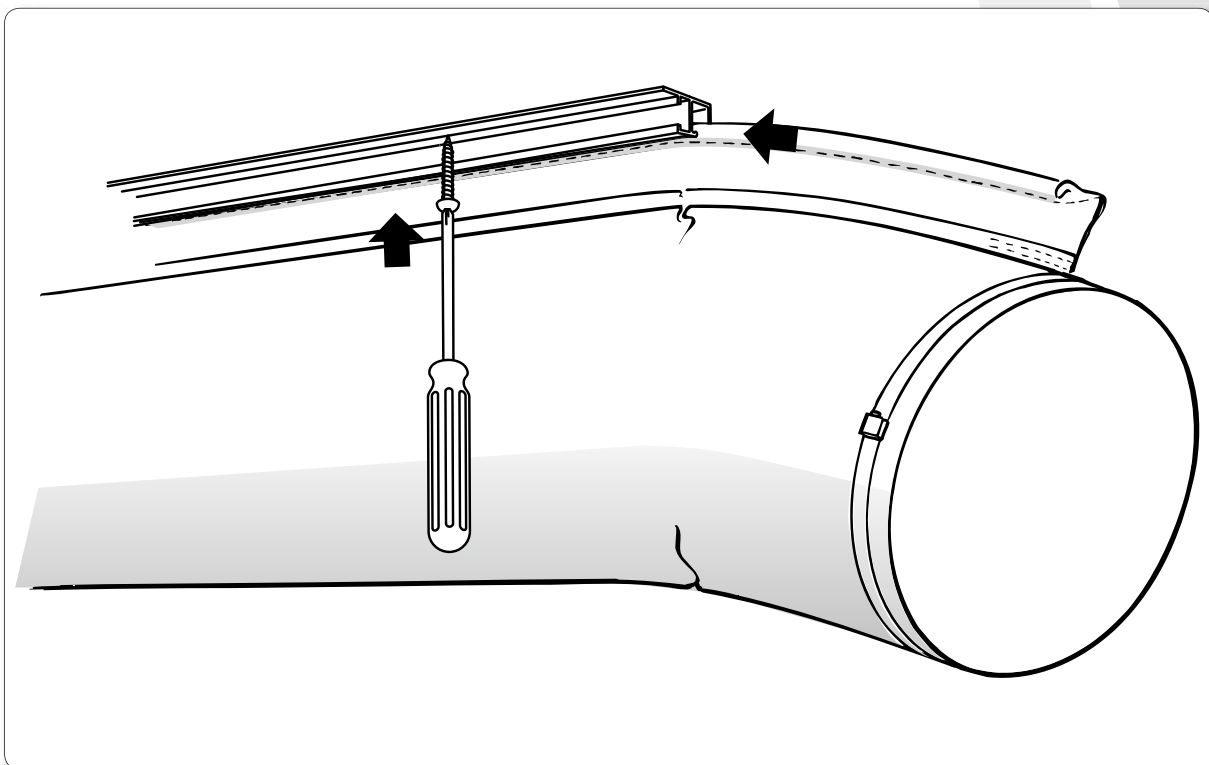

**Wingrail connector**  
Wingrail samler

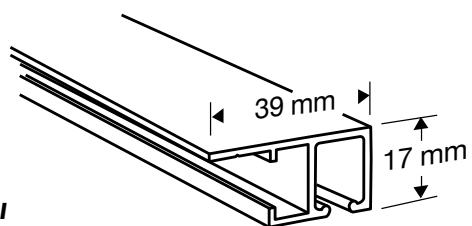

**Wingrail**  
Wingrail

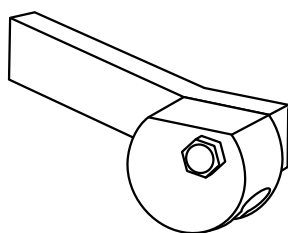

**Fasttrack feeder tool for wingrail**  
Montage værktøj til fasttrack/wingrail



**Mini cleat**  
Skødeklemme

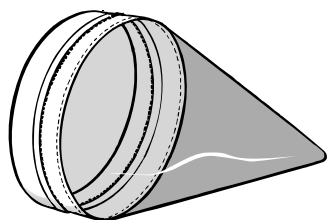

**Static Regain diffuser**  
SRD

## 1. Installing round outlets with Fasttrack onto ceiling mounted Wingrail

- Attach Wingrail to ceiling using screws for every 300-1000mm depending on type of ceiling and size of outlet. Note: the wing on the rail has a groove for lining up when drilling the holes needed in the rail.
- Sections of Wingrail is joined by sliding the Wingrail connector into the side groove of the rail, and then tightening the allen screws. When tightening the allen screws, the 2 sections of rail will self-align.
- The Fasttrack cord fitted to the outlet is slid into the rail opening, and can now be pushed/pulled into the rail. If you have ordered our special Fasttrack feeder tool, this must be fitted into the side groove prior to sliding the outlet into the rail. Using the special feeder tool the outlet can be pull onto the rail very easily with a minimum use of force.
- The outlet is fixed to the steel duct or fan using clamp.
- If "Luxe bottom" was ordered you will also have received a small cleat (stamped Mini cleat) per outlet. This cleat is mounted directly onto the rail, at the end of the rail where the bottom of the outlet will be located. The cleat is fitted using the included special flat nuts and bolts. When the outlets are ordered with the "Luxe type bottom" the outlets have a pull cord attached at the bottom end. This cord is pulled tight and fixed into the cleat. Following this, the cord can be shortened as needed.

## 1. Montering af rund posekanal med Fasttrack, i loftsmonteret Wingrail skinne

- Skinne fastgøres til loft med skruer per 300-1000mm, afhængigt af loftstype samt kanaldimension. Bemærk at skinnen har et spor i montage fligen, for nemmere at styre boremaskinen, samt sikre korrekt hul placering.
- Hvor skinner skal samles indskydes skinnesamler i samlersporet, og fastspændes. Herved sikres at de enkelte skinnestykker liner korrekt op.
- Posekanalens Fasttrack føres ind i Wingrail skinnens montage spor, og kan herefter trækkes/ skubbes ind i skinnen. Såfremt der er bestilt vort specielle montageværktøj for Wingrail skydes denne først ind i samlersporet på skinnen. Herefter kan posen ganske ubesværet trækkes på skinnen, med et minimum af trækpåvirkning nødvendig.
- Posekanalen fastgøres på stålkanalen/ventilator ved hjælp af spændebånd.
- Hvis der er bestilt "Luxe-bund" til posen, medfølger ligeledes et stk. "mini-cleat" (skødeklemme) per pose. Denne monteres direkte på skinnen (der medfølger special møtrikker samt skruer til dette formål), i den ende hvor posekanalens bund sidder. Når der er bestilt "Luxe-bund" er posen udstyret med en kraftig isyet snor ved bunden. Denne snor bruges til at strække posen helt ud, hvorefter snor kan kiles fast i skødeklemmen. Snoren kan slutteligt afkortes efter behov.

GB

#### Washing instructions

Cleaning of polyester and Trevira CS

Wash 2-4 times at max 40°C with washing powder in accordance to instructions by manufacturer.

If outlets are heavily soiled, they should be rinsed between washes. If the outlets are to be disinfected, add up to 200 grams of active chlorine to the final rinse water (N.B. colored socks can lose some of their color when disinfected)

Rinse outlets in clean cold water.

Socks can be spin dried, the exception being outlets with internal rings. Here the rings must be removed prior to drying.

#### Chemical cleaning of polyester and Trevira CS

Chemical cleaning of outlets should only be attempted in cases where the outlets are slightly dirty. To achieve some degree of disinfection, it is recommended to use chemical cleaning with perchlorethylen.

#### Washing or chemical cleaning, clean room materials

Washing or chemical cleaning of clean room materials is not recommended under normal circumstances, but is possible following the procedures given for Polyester and Trevira CS material. If the fabric turns slightly grey during operation, the pre-filtration should be examined and possibly exchanged for a filter better suited. During the washing procedure, particles can be picked up by the fabric and later blown into the room. If the clean room socks are being washed there is no further guarantee for the function of the socks from EURO AIR, with regards to particle count.

#### Cleaning of Inject outlets

EURO AIR Inject outlets do not require cleaning from a flow technical point of view, however aesthetic or hygiene conditions may necessitate the cleaning of the outlets. EURO AIR Inject systems can be cleaned manually on the outside and on the inside. For this purpose a thin water/soap dilution and a brush or a sponge should be used (standard grade washing detergent can be used). After the cleaning the Inject Socks should be rinsed with clean water. If the Inject Sock is very dirty the inside of the sock should be turned out and swept or vacuumed. Use of Hydrocarbon based solvents can cause damage. Under no circumstances use solvents containing Chlorate, this will deteriorate the PVC coating, causing the material to turn brittle, eventually cracking can occur.

#### Cleaning of M0 Outlets (Glass fibre weave)

These outlets must only be cleaned by means of a damp cloth. A standard commercial grade detergent can be used in a watery solution for this purpose. Outlets must be allowed to drip dry.

DK

#### Vaskeanvisning

Vask af polyester og Trevira CS

Vask 2-4 gange ved max. 40°C, tilsæt vaskepulver i dosering svarende til fabrikantens anvisning. Såfremt posekanalerne er meget snavsede bør disse skylles mellem hver vask. Efter endt vask efterskylles i rent koldt vand. Såfremt poserne ønskes desinficeret kan dette opnås ved at tilsætte max. 200g aktivt klor til sidste hold skyllevand (vær opmærksom på at farvede kanaler ved denne desinficering kan blive let blegede). Såfremt der desinficeres efterskylles igen med rent koldt vand. Kanaler med interne ringe kan centrifugeres, blot skal ringene demonteres før dette kan foretages.

#### Kemisk rens af polyester og Trevira CS

Kemisk rens af tekstil kanaler bør kun anvendes i tilfælde hvor disse har en lav- til middel tilsmudsgrad. Ved kemisk rens bør der anvendes perkloræthylen, og kanalerne bør udluftes.

#### Vask eller kemisk rens af renrumsmaterialer

Vask eller kemisk rens af renrumsmaterialer anbefales ikke under normale omstændigheder, men er dog muligt som nævnt ovenfor for polyester og Trevira CS materiale. Hvis kanalen har en tendens til at blive grålig i farven bør forfiltret efterses, og eventuelt udskiftes med filter af højere filterklasse. Under rense- eller vaskeprocessen kan pose materialet blive forurenet med støvpartikler og lignede, hvorfor Euro Air A/S fralægger sig ansvaret for renrumsklassen efter en eventuel vask.

#### Rengøring af injekt materiale

Kan ikke maskinvaskes. Euro Air injekt kanaler kræver ikke vask eller rens ud fra et luftteknisk synspunkt, idet dette materiale er ikke-permeabelt, det vil sige, materialet stopper ikke til selv om der støvpartikler tilstede i indblæsningsluften. Poserne kan rengøres manuelt på yder- og inderside med en tynd sæbeopløsning vha. svamp og børste. Efter rengøring vaskes poserne over med rent vand. Der må under ingen omstændigheder bruges klorholdige rengøringsprodukter, idet klor kan nedbryde PVC-belægningen.

#### Rengøring af glasfibervæv

Kan ikke maskinvaskes. Kan rengøres med fnugfri klud påført tynd opløsning af sæbevand. Skylles efterfølgende med rent vand og dryp tørrer.



MI500002