

Series A28 Two stage Thermostats

Introduction

These thermostats are designed for various types of heating, cooling, ventilation, or air-conditioning applications. All models have two SPDT switches providing the following control possibilities:

- 2 stage heating
- 2 stage cooling
- heating/cooling with automatic changeover

Models are provided with a standard IP30 case or splashproof, dust-tight IP65 plastic case

Description

Controls are compact with fixed differential per stage and (on most models) adjustable differential between stages. Liquid filled element provides wide range, constant differential over whole range and no influence from barometric pressure. Since the bulb contains the major portion of the total fill the thermostat may be considered as cross-ambient, capillary and cup temperature variations affect the operating point only slightly due to the small amount of fill they contain.

For quantity orders it is possible to have the below stated optional constructions

- Without case and cover for panelmounting
- Close differential per stage
- Different capillary lengths

All standard IP30 enclosure models have a universal way of adjustment. For this purpose a knob and sealing cap are enclosed.



A28QA
splashproof dust-tight thermostat with 2m
capillary and style 1b bulb (left).

A28AA
thermostat with style 3 element (right).

Feature and Benefits

<input type="checkbox"/> Liquid filled sensing element	No cross ambient temperature problems Constant differential over the whole range
<input type="checkbox"/> Dust tight Penn switch	Prevents pollution of the contacts by electrostatic influences.
<input type="checkbox"/> IP65 protection class models available	Suitable for outdoor applications
<input type="checkbox"/> Front adjustment	Less mounting space required

Note

These controls are designed for use only as operating controls. Where an operating control failure would result in personal injury or loss of property it is the responsibility of the installer to add devices or systems that protect against, or warn of, control failure.

Adjustment

Models "set low" (see also cover label):
The dial indicates the switch point "SP1" (see switching diagram).

Models "set high" (see also cover label):
The dial indicates the switch point "SP2" (see switching diagram)

For IP30 models the standard screwdriver adjustment can be converted easily in the field to knob adjustment. Also concealing of adjustment is possible after installation.

Contact function

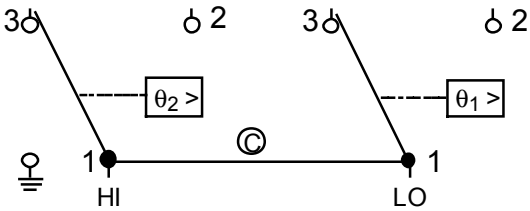

$$\theta_1 < \theta_2$$

Fig. 1
1-2 closes on temperature increase.
C Removable jumper.

Switching diagram (Heating Mode)

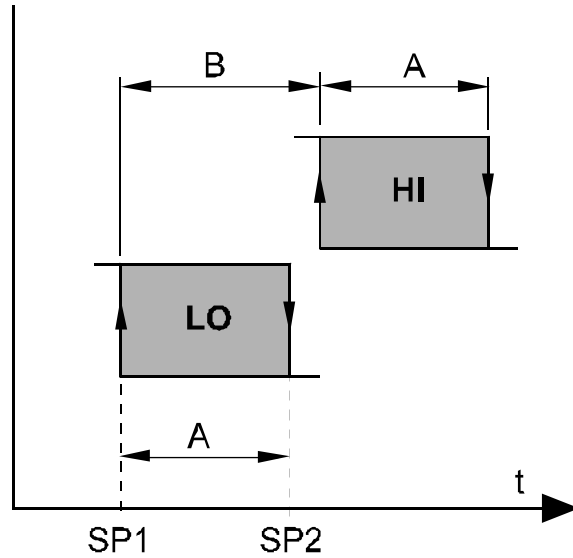

Fig.2

- A** Differential per stage.
- B** Differential between the stages.
- SP1** Dial setting (for exceptions see 'SP2').
- SP2** Dial setting (range 0 to 43°C and 1 to 60°C).
- t** Temperature increase.
- LO** Low stage.
- HI** High stage.

Repair and Replacement

Repair is not possible. In case of an improperly functioning control, please check with your nearest supplier. When contacting the supplier for a replacement you should state the type/model number of the control. This number can be found on the data plate or cover label.

Type number selection table:

Range (°C)	Diff. per stage (K)	Diff. between stages (K)	Element style (cap. length)	Bulb size (mm)	Element finish	Setting (see page 2 adjustment)	Max. bulb temp (°C)	Bulb well (optional)	Order number
------------	---------------------	--------------------------	-----------------------------	----------------	----------------	---------------------------------	---------------------	----------------------	--------------

Type A28AA Capillary Thermostats, General Purpose IP30

-35 to +10	2	1 to 4	1b(2m)	9.5 x 110	Tin-plated	set low	60	WEL14A602R	A28AA-9006
-5 to +28	1.5	1 to 4	1b(2m)	9.5 x 135	Tin-plated	set low	60	WEL14A603R	A28AA-9007
-5 to +28	1.5	1 to 4	1b(5m)	9.5 x 135	Tin-plated	set low	60	WEL14A603R	A28AA-9106
1 to 60	2	1 to 4	1b(3m)	9.5 x 115	-	set high	85	WEL14A602R	A28AA-9118

Type A28AA Space thermostat

0 to +43	1.5	1 to 4	3	-	St. Steel	set high	60	-	A28AA-9113
----------	-----	--------	---	---	-----------	----------	----	---	-------------------

Type A28QA Capillary Thermostats, Splashproof IP65, Dust-tight Case

-35 to +10	2	1 to 4	1b(2m)	9.5 x 110	Tin-plated	set low	60	WEL14A602R	A28QA-9110
-5 to +28	1.5	1 to 4	1b(2m)	9.5 x 135	Tin-plated	set low	60	WEL14A603R	A28QA-9111
-35 to +40	2	1 to 4	1b(3.5m)	9.5 x 110	Tin-plated	set low	60	WEL14A602R	A28QA-9114
1 to 60	2	1 to 4	1b(3m)	9.5 x 115	-	set high	60	WEL14A602R	A28QA-9115

Type A28QA Space Thermostats, Splashproof IP65, Dust-tight Case

0 to +43	1.5	1 to 4	3	-	St. Steel	set high	60	-	A28QA-9113
----------	-----	--------	---	---	-----------	----------	----	---	-------------------

Type A28QA Capillary Thermostats, Splashproof IP65, Dust-tight Case, Concealed adjustment. For use on cooling-towers evaporative condensers, or air cooled condensers

5 to 50	2	4	1b(2m)	9.5 x 110	Tin-plated	set low	100	WEL14A602R	A28QA-9101
---------	---	---	--------	-----------	------------	---------	-----	------------	-------------------

Type A28QJ Capillary Thermostats, Splashproof IP65, Dust-tight Case For use on heat pumps and heat recovery units

10 to 95	1.5	1 to 4	1b(3m)	9.5 x 100	-	set low	115	WEL14A602R	A28QJ-9100
----------	-----	--------	--------	-----------	---	---------	-----	------------	-------------------

Note: If what you need is not in the specific type numbering selection table then please contact your representative.

Sensor styles

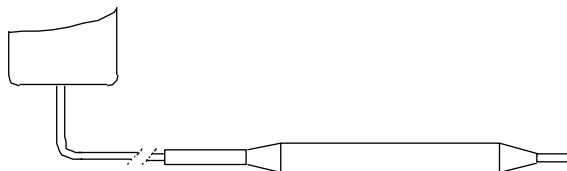

Fig. 3
Style 1b

swaged bulb, can be used with closed-tank connector **FTG13A-600**

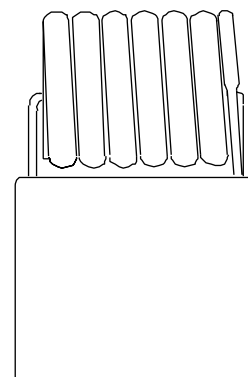
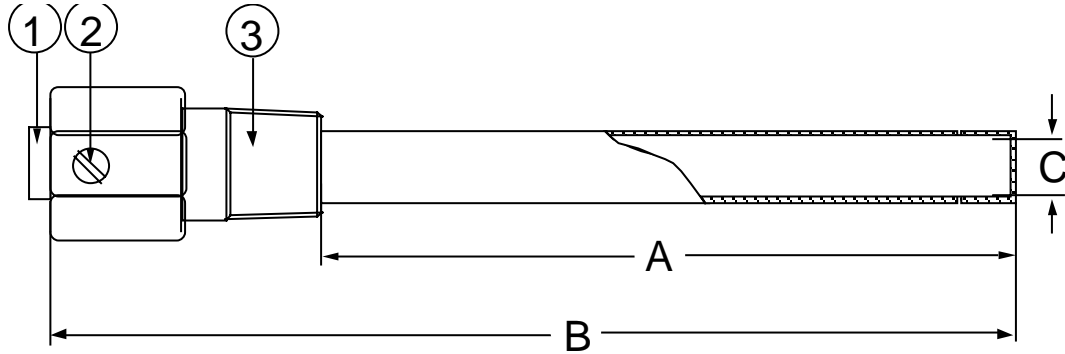

Fig. 4
Style 3 (coil)

Accessories (optional)



Order no.	Dimension A	Dimension B	Dimension C Internal
WEL14A602R	125 mm	171 mm	9.8 mm
WEL14A603R	147 mm	193 mm	9.8 mm

1. Bushing
 2. Set screw
 3. Adapter, 1/2"-14 NPT
- Bulb well (brass, copper pipe)**

Fig. 5

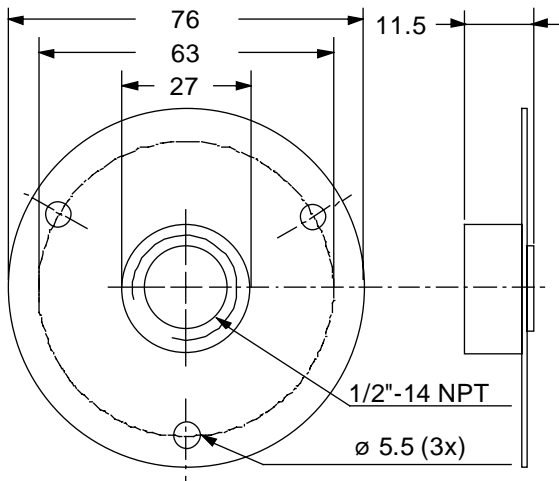
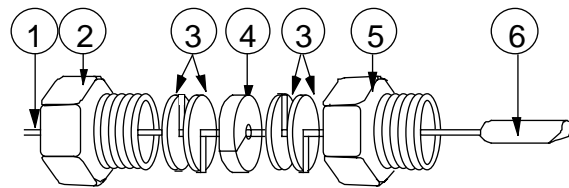

Fig. 6

Duct flange to be used with closed-tank connector FTG13A-600R.
Order number T-752-1001



1. Style 1b bulb support tube
2. Packing nut
3. Washer
4. Packing
5. Adapter, 1/2"-14 NPT
6. Bulb

Fig. 7

Closed-tank connector
Order number FTG13A-600R

Dimensions (mm)

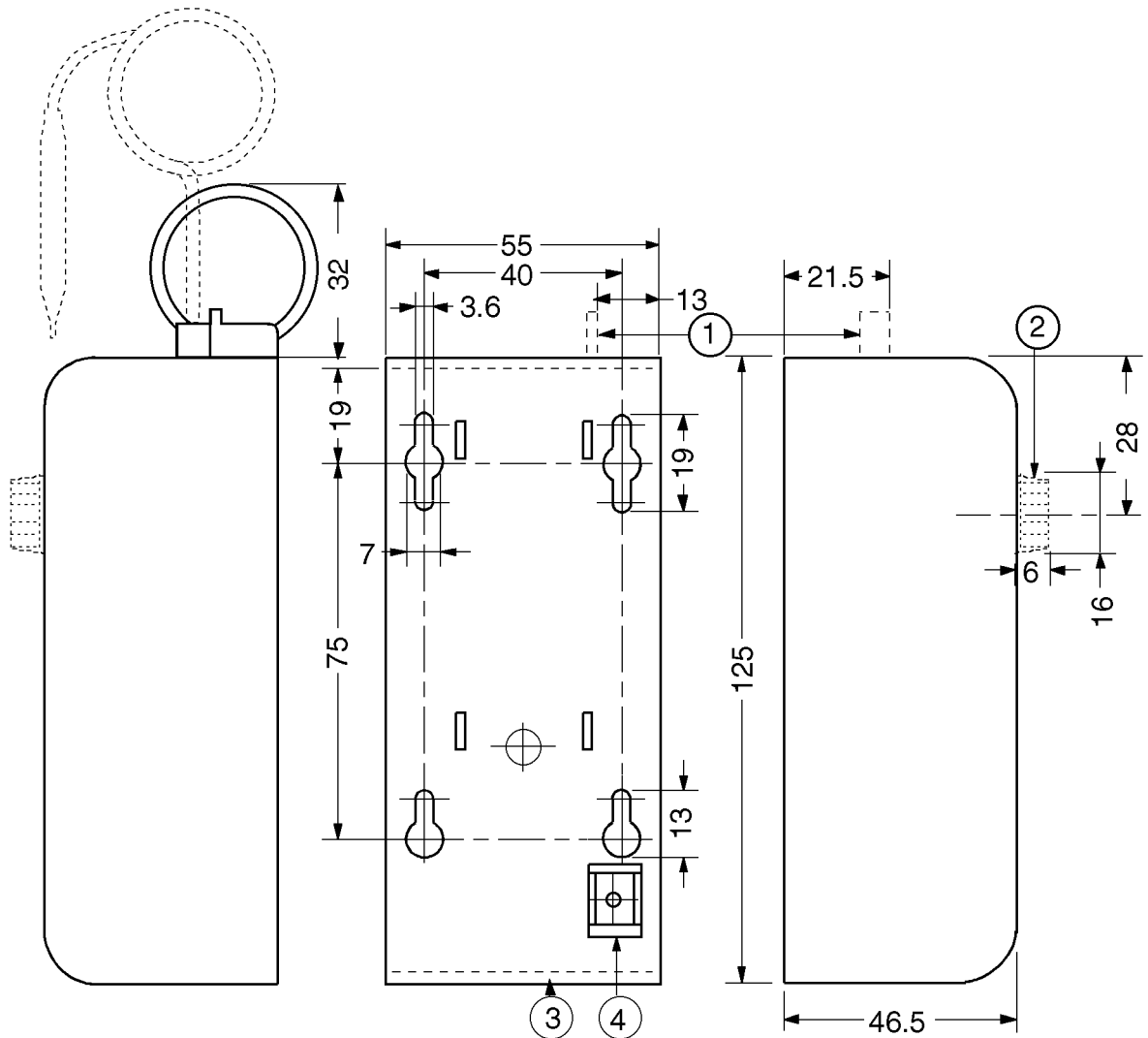

Fig. 8
A28AA (standard IP30 enclosure)

- 1 Reset lever
- 2 Knob packed separately with the control
- 3 22.3 mm dia. cable inlet hole for PG-16
- 4 Earth screw

Dimensions (mm)

Fig. 9
A28QA/QJ (splash-proof IP65, dust-tight enclosure)

- 1** Knob (knob models only)
- 2** Cable grommet \varnothing 5 to \varnothing 13 mm
- M** 4 Mounting holes \varnothing 4.5 mm use 2 holes only

Notes

Specifications

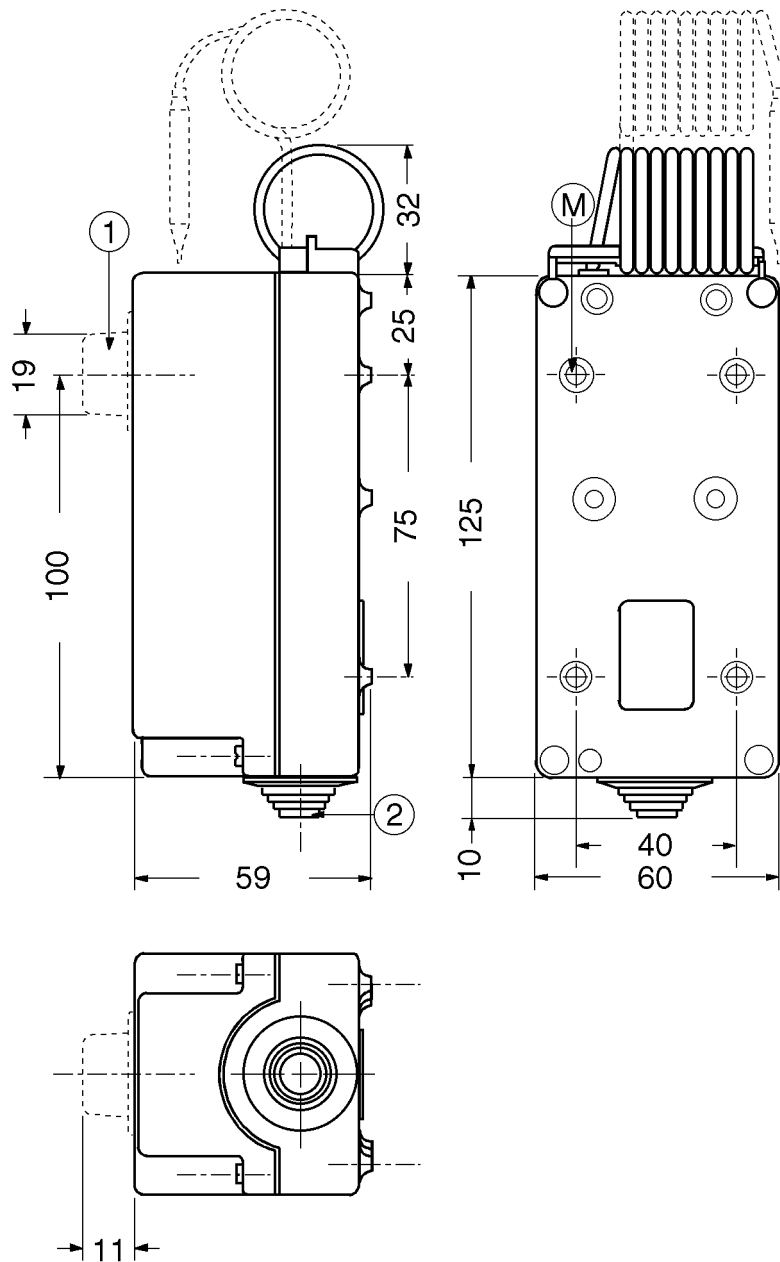
Type number	A28AA (standard IP30 enclosure)		A28QA/QJ (splashproof, dust-tight IP65 enclosure)	
Element style	Style 1b bulb element	Style 3	Style 1b bulb element	Style 3
Application	General purpose -	Space -	General purpose Cooling towers and air-cooled condensers	Space (out-door and agriculture) -
Operating ranges	See type number selection table			
Differentials	See type number selection table			
Adjustment	Universal	-	External knob (general purpose) Concealed under cover (cooling-tower and air-cooled condensers) Controls with adjustable differential between stages have an adjustment lever under the cover	
Material Case Cover	1.75 mm cold-rolled zinc plated steel 1.5 mm ABS plastic		Polycarbonate Blue-colour finish Polycarbonate Blue-colour finish	
Conduit opening	22.3 mm dia. hole for PG16		Cable grommet. Conduit opening also applicable for PG16 connector	
Amb. temp. limits	-35 to +55°C		-35 to +55°C	
CE Conformity	According to low voltage directive and EMC directive			
Electrical ratings	~15(5)A 230V		~15(5)A 230V (A28QJ: ~15(3)A 230V)	
Enclosure	IP30		IP65	
Shipping weight	ind. pack 0.4 kg		ind. pack 0.5 kg	
	overpack 10 kg (24 pcs.)		overpack 12 kg (24 pcs.)	

The performance specifications are nominal and conform to acceptable industry standards. For applications at conditions beyond these specifications, consult the local Johnson Controls office or representative. Johnson Controls shall not be liable for damages resulting from misapplication or misuse of its products.

**JOHNSON
CONTROLS**

Johnson Controls International, Inc.

Headquarters: Milwaukee, WI, USA
 European Headquarters: Westendhof 8, 45143 Essen, Germany
 European Factories: Lomagna (Italy), Leeuwarden (The Netherlands) and Essen (Germany)
 Branch Offices: Principal European Cities.

This document is subject to change

Printed in Europe