

Series A36

3- and 4 Stage Thermostats for Refrigeration, Cooling, Heating, Ventilation and Air-conditioning

Introuction

Designed for multi-stage thermostatic operation of electrically controlled equipment such as:

- packaged liquid chillers
- heat pumps
- electric duct heaters
- computer room airconditioners

Description

Models are available in 'open' construction for panel mounting. Single knob adjustment moves the entire staging band up and down within the range of the control. The differential on each stage and sequencing between stages are factory set.

This permits the OEM to completely engineer the cycling of their equipment without the hazard of field mis-adjustments and erratic sequencing.



A36 Three and Four Stage Thermostat

Note

These controls are designed for use only as operating controls. Where an operating control failure would result in personal injury or loss of property it is the responsibility of the installer to add devices or systems that protect against, or warn of, control failure.

Feature and Benefits	
<input type="checkbox"/> Dust-tight SPDT switches	Prevents pollution of the contacts by electrostatic influences
<input type="checkbox"/> Cushion mounted	Prevents vibrations and chattering contacts
<input type="checkbox"/> Operation from a single, liquid filled element	Easy mounting
<input type="checkbox"/> Case compensation standard on all models	Assures uniform performance at different ambient conditions

Repair and Replacement

Repair is not possible. In case of an improperly functioning control, please check with your nearest supplier. When contacting the supplier for a replacement you should state the

type/model number of the control. This number can be found on the data plate or cover label.

Contact functions

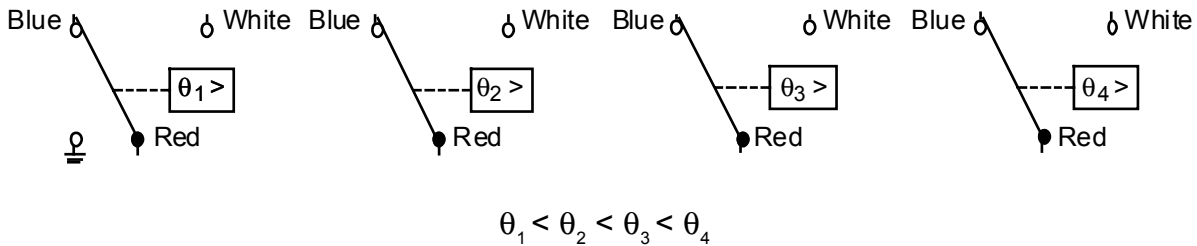
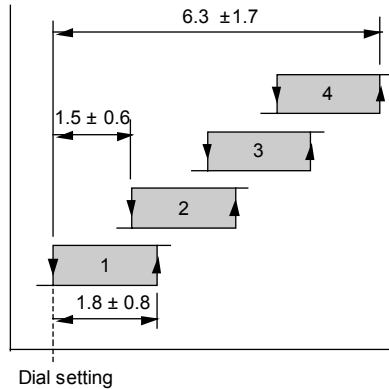
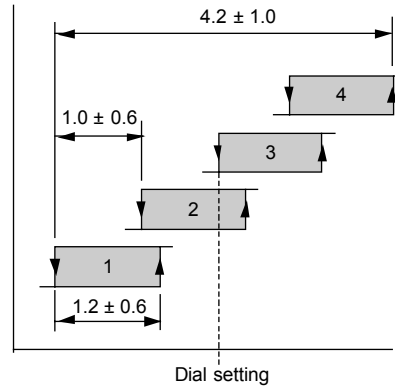

Fig. 1
Red - white closes on temperature increase.

Adjustment codes and tolerances



B1 Chiller/refrigeration standard differential



B2 Range close differential

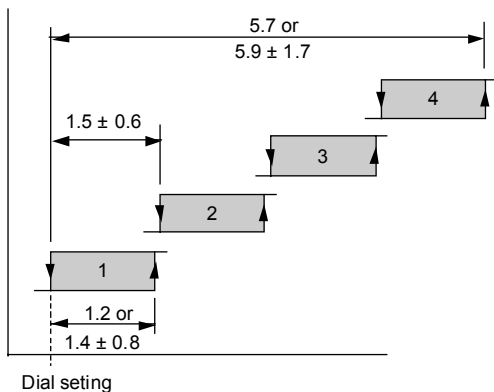

C1 Air-conditioning/heating standard differential

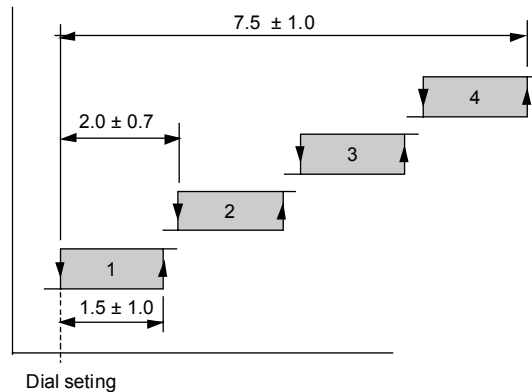

D2 Range wide differential

*T*ype number selection table:

Range °C	Diff. each stage	Between stage diff.	Adj. code	Bulb 9.5 mm Ø x length (mm)	Cap. length (m)	Special features	Electrical rating Amp. ~230V	Order number
----------	------------------	---------------------	-----------	-----------------------------	-----------------	------------------	------------------------------	--------------

3 stage models

-18 to +20	1.8	1.5	B1	125	5.0	PVC armoured	15(5)	A36AGA-9101
-18 to +20	1.8	1.5	B1	125	3.5	PVC armoured	15(5)	A36AGA-9102
-18 to +20	1.2	1.5	B2	125	3.5	PVC armoured	15(3)	A36AGB-9103
15 to 35	1.2	1.0	C1	140	3.5	PVC armoured	15(5)	A36AGA-9103

4 stage models

-18 to +20	1.8	1.5	B1	125	3.5	PVC armoured	15(5)	A36AHA-9105
-16 to +20	1.8	1.5	B1	125	5.0	PVC armoured	15(5)	A36AHA-9107
15 to 35	1.2	1.0	C1	140	3.5	PVC armoured	15(5)	A36AHA-9108
10 to 95	1.5	2.0	D2	100	3.0		15(3)	A36AHB-9103
-18 to +20	1.2	1.5	B2	125	3.5	PVC armoured	15(3)	A36AHB-9104
-18 to +20	1.2	1.5	B2	125	5.0	PVC armoured	15(3)	A36AHB-9105
-15 to +30	1.4	1.5	B2	110	5.0		15(3)	A36AHB-9109

Accessories (optional)

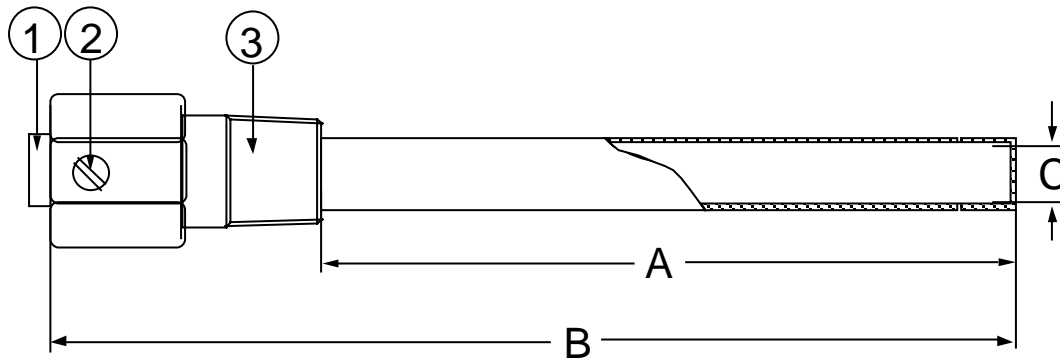

Order no.	Dimension (A)	Dimension (B)	Dimension (C) Internal
WEL14A602R	125 mm	171 mm	9.8 mm
WEL14A603R	147 mm	193 mm	9.8 mm

Fig. 3
Bulb well (brass, copper tube)

- C. Bushing
- D. Set screw
- E. Adapter, 1/2"-14 NPT

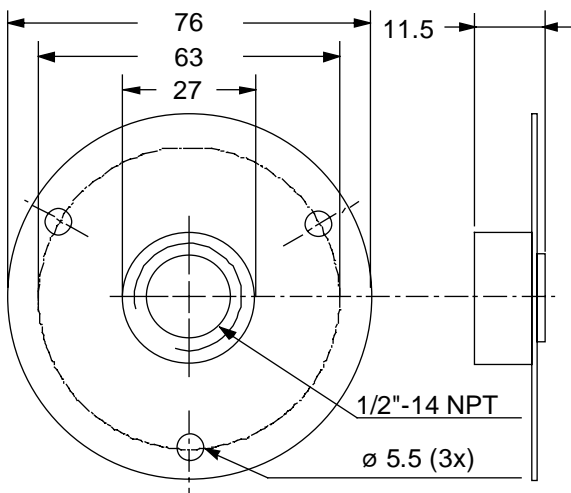

Fig. 4
Duct flange to be used with closed-tank
connector FTG13A-600R.
order number T-752-1001

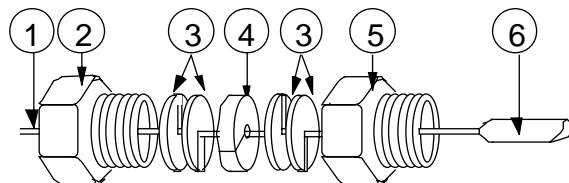

Fig. 5
Closed-tank connector
order number FTG13A-600R

- 1. Style 1b bulb support tube
- 2. Packing nut
- 3. Washer
- 4. Packing
- 5. Adapter, 1/2"-14 NPT
- 6. Bulb

Element styles

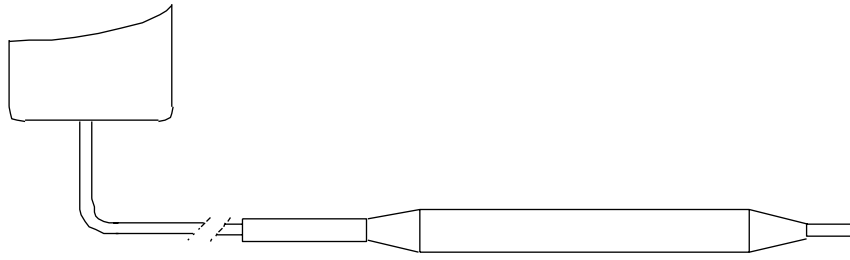
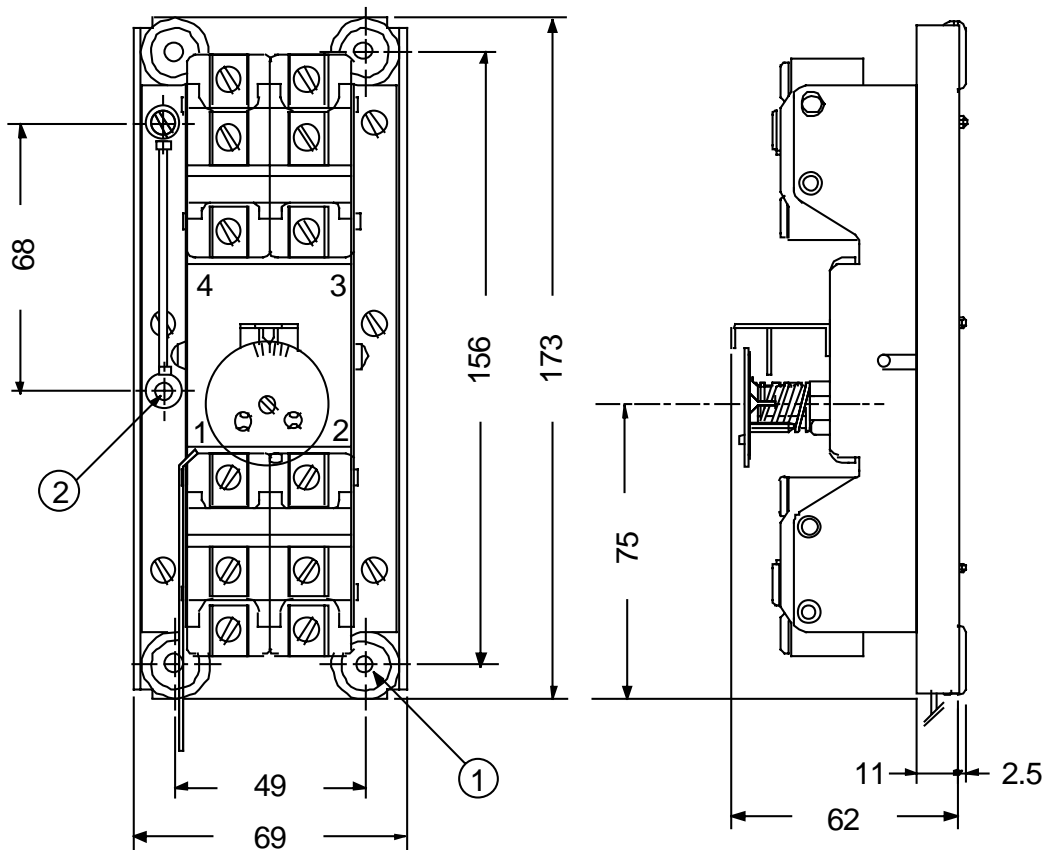

Fig. 6
Style 1b
Can be used with closed tank connector FTG13A-600RR

Dimensions (mm)



1. 4 Mounting grommets \varnothing 4.5 mm
2. Earth wire

Fig. 7

Notes

Notes

Specifications

CE Conformity	According to low voltage directive and EMC directive	
Element style	Liquid filled, copper bulb Ø 9.5 mm and capillary tube	
Operating ranges and differentials	See corresponding type number selection table.	
Adjustment	Calibrated dial and pointer	
Max. bulb temperature after installation	50 °C	
	115 °C for A36AHB-9103	
	75 °C for A36AHB-9109	
Max. temperature	+55 °C	
Shipping weights	Individual pack	1 kg
	Over pack	14 kg (14 pcs)
Contact functions	SPDT, snap-acting, enclosed and dust-tight switches	

The performance specifications are nominal and conform to acceptable industry standards. For applications at conditions beyond these specifications, consult the local Johnson Controls office or representative. Johnson Controls shall not be liable for damages resulting from misapplication or misuse of its products.



Johnson Controls International, Inc.

Headquarters: Milwaukee, WI, USA
 European Customer Service Center: Westendhof 3, D-45143 Essen, Germany
 European Factories: Lomagna (Italy), Leeuwarden (The Netherlands) and Essen (Germany)
 Branch Offices: Principal European Cities.

This document is subject to change

Printed in Europe