

MS Electronic Controls for general purpose and multi stages controls

/ntroduction

This range of versatile controls is intended for single or multistage (2 or 4 stages) applications such as heating, cooling but also humidity or pressure depending on the input type.

This range incorporates all control functions as required by modern applications and it exists in both panel mount and DIN rail enclosures. Particular attention has been given to its style in order to better suit your machine design.

This complete range of microprocessor based controls offers innovative features and "state of the art" technology.



Panel and DIN Rail Models

Features and Benefits	
<input type="checkbox"/> Attractive Panel mount and DIN rail mount enclosure	Easy and quick installation
<input type="checkbox"/> Up to 4 relays in panel mount enclosure	Reduced space
<input type="checkbox"/> 230 Volt power supply models available	Reduced installation time
<input type="checkbox"/> Accept A99 and 0-10 Volts sensor signal depending on models	Opens a wide range of potential applications
<input type="checkbox"/> Power supply to sensors on 0-10 Volts models available from controller	Reduced wiring
<input type="checkbox"/> Accurate and interchangeable IP 68 sensor	Accurate control performance No recalibration needed
<input type="checkbox"/> Wide range of enclosures for sensors available	Possibility to match a wide variety of temperature sensing needs
<input type="checkbox"/> Keyboard lock	Avoids accidental tampering by personnel
<input type="checkbox"/> SMD technology	Higher quality and reliable components

Features

Display

The display has 3 LED digits with +/- indication and accepts a temperature range from -40 to 70 °C (-40 to 158 °F) with a precision of 1 °C or F. When used with a 0-10 Volts signal, the displayed value can be configured from -40 to 100.

Sensor input

This range of controllers uses Johnson Controls A99 temperature sensor. Its accuracy is within 0.5 °C between -15 and 75 °C. Its tolerance increases at temperatures outside this range, as shown below.

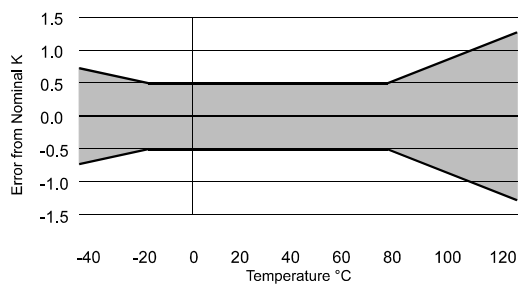

Its gas tight packaging makes it the best sensor for refrigeration applications. *For details please refer to A99 documentation.* An offset of the measured temperature can be configured for temperature compensation or cable extension.

One stage and two stages controls are also available with a 0-10 Volts input making it compatible with a wide variety of standard sensors, and among others it can be used with HT9 humidity sensors and P99 pressure sensors from Johnson Controls. *For details please refer to HT9 and P99 documentation.* A 12 Volts dc signal is available from the controller in order to power the sensor. Both with temperature and voltage input, controllers allow an offset of the measured value that can be used for compensation.

Adjustable setpoint limits

The setpoint range can be limited in order to avoid "too high" or "too low" setpoint setting of the equipment. The final user cannot set a setpoint value exceeding these limits.

Function mode

A special mode allows you to select the type of action you require. Direct or reverse (respectively cooling or heating, dehumidifying or humidifying, etc...). Pre-set functions have been programmed for you, avoiding possible mistakes of stages crossing. Furthermore, the configuration of this parameter is in a different table than other parameters preventing from final user to alter the defined control strategy.

Anti short cycle protection

In order to protect your equipment, all models have two built-in anti short cycles. The first one is dedicated to cooling stages while the second is used for heating stages. This allows you to use this features only when required.

Keyboard locking

A sequence of key strokes allows you to disable/enable modification of the internal parameters. This prevents unauthorised personnel from making parameter modifications.

Soft start

When switching on your equipment, the process variable might be very different from your setpoint, and a full load might be incompatible with your process. In this case, the controller allows to increase the setpoint degree per degree at a predefined rate (in degree per minutes).

Self-testing procedure

This feature helps you to check the installation and configuration of the controller once installed. After a key stroke sequence (▼) + (▲), it will cycle all outputs and flash all LEDs.

Alarm management

All devices include a high and low limit alarm. This alarm is related to the main setpoint of the controller and displays "Hi" or "Lo" in case of exceeding those limits. A delay can be configured in order to prevent non significant events from triggering the alarm. The differential of the alarm is also adjustable.

Events such as a disconnected or short circuited sensor will be detected, signalled and will results in the shut OFF of the installation.

Display updating time

This is very handy to avoid displaying intermittent changes of process variable. It provides an adjustable time delay till the display is "refreshed".

Units

Units can be selected from degree Celsius or Fahrenheit.

Configuration

Available keys	Action
Up	Check 2 nd sensor value (if applicable) and DI status. Scroll parameters, change values
Down	Check DI status and 2 nd sensor value (if applicable). Scroll parameters, change values
SET for 3" < t < 7"	Go to setpoint setting
SET for 7" < t < 15"	Go to parameters setting
SET+DN for t > 7"	Mode selection
UP+DN for t > 5"	Self test
SET+UP+DN for t > 10"	Lock/Unlock keyboard

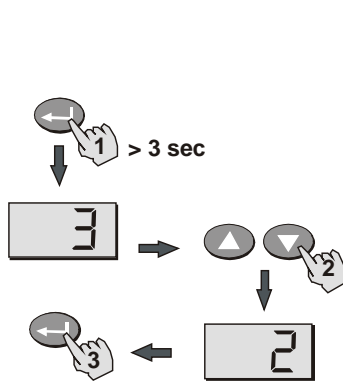

Set point

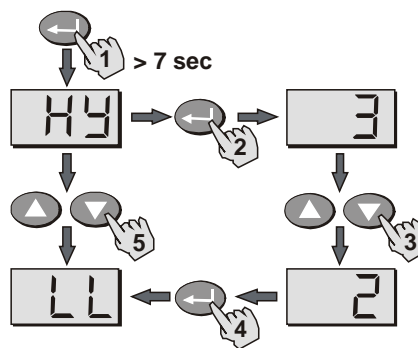

Parameters

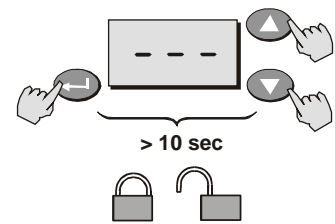

Keyboard Lock / Unlock

Dimensions (in mm)

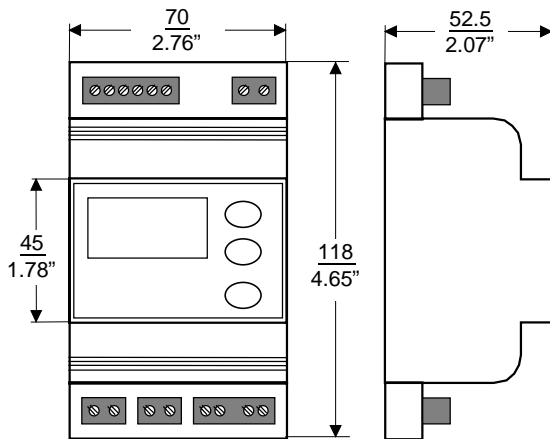

DIN Rail enclosure

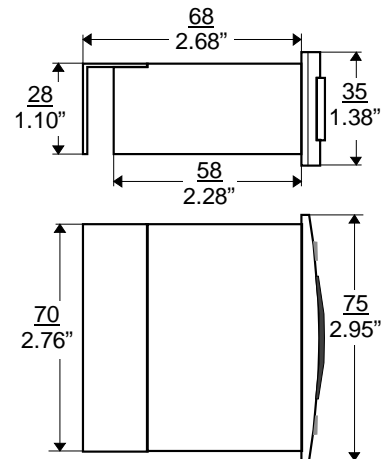

Panel cut-out for panel mount versions

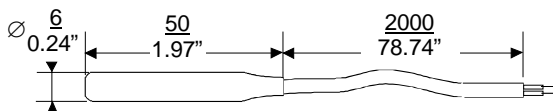

A99BB-200C Sensor

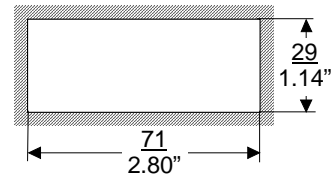

Panel cut-out for panel mount versions

Wiring Instruction

WARNING

When wiring and servicing make sure that:

- the electric supply to the actuator is switched off to avoid possible damage to the equipment, personal injury or shock.
- you do not touch or attempt to connect or disconnect wires when electric power is on.

Note

These controls are intended to control equipment under normal operating conditions. Where failure or malfunction of the controls could lead to an abnormal operating condition that could cause personal injury or damage to the equipment or other property, other devices (limit or safety controls) or systems (alarm or supervisory systems) intended to warn of or protect against failure or malfunction of the controls must be incorporated into and maintained as part of the control system.

Display

These devices are to display temperature and humidity:

Description

Through a switch selection, you can select the range in °C and °F. Separate models are available to display %. In case of a 0-10 Volts input type, the power supply to the sensor is available from the controller (12 Volts dc).

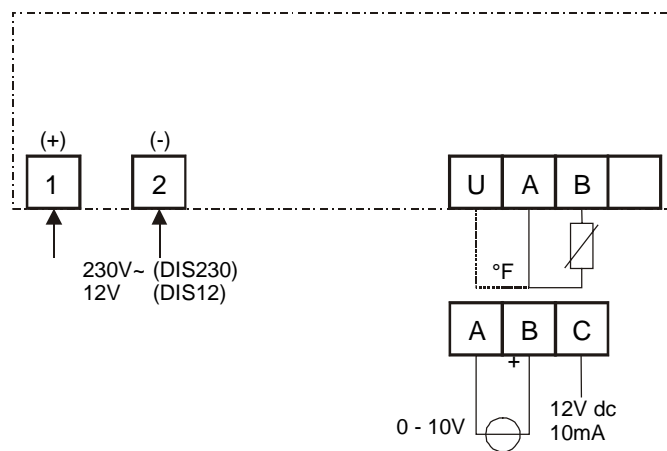

Display DIS

Selection table

Item code	Enclosure	Power supply	Input type	Shipping weight
DIS12T-1C	Panel 75x35	12 Vac/dc	A99, sensor included, 2m	200 g
DIS230T-1C	Panel 75x35	230 Vac	A99, sensor included, 2m	260 g
DIS12V-1C	Panel 75x35	12 Vac	0 to 10 V, no sensor	160 g
DIS230V-1C	Panel 75x35	230 Vac	0 to 10 V, no sensor	220 g

One stage controls - MS1

This device is designed to control one stage applications which can be in the following configuration:

- One direct stage (cooling, dehumidifying,...).
- One reverse stage (heating, humidifying....).

Description

The output is equipped with a SPST or SPDT relay capable of driving units up to 16(12) Amps. It also features, in its standard version, a low power output dedicated for alarm signalling sufficient to drive an LED, a 24 V light bulb or a buzzer.

Note: A detailed list of available parameters and their description can be found at the end of this documentation.

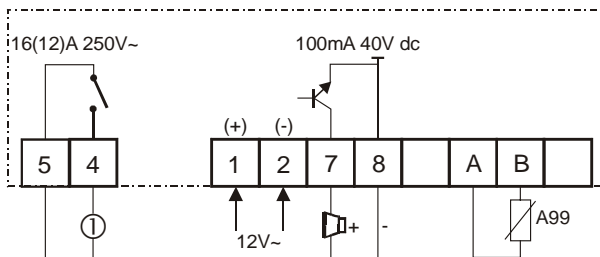

Wiring diagram a)

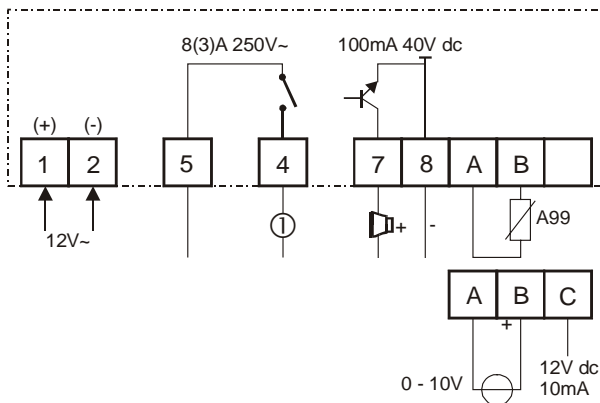

Wiring diagram b)

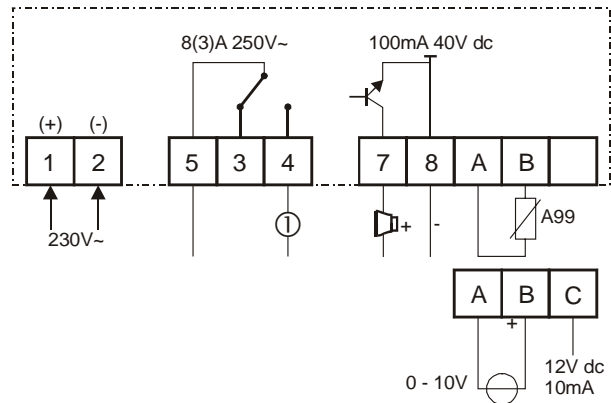

Wiring diagram c)

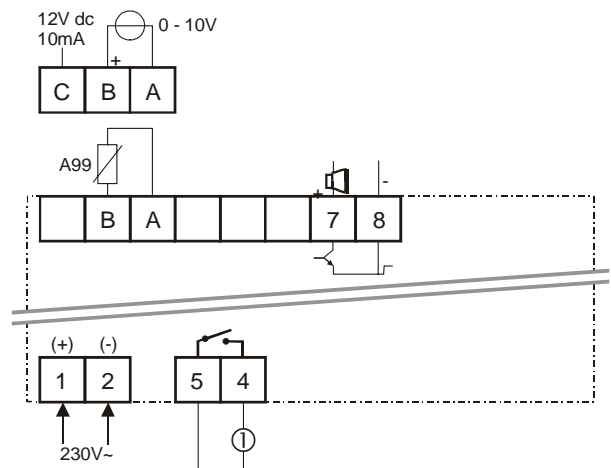

Wiring diagram d)

Selection table:

Item code	Enclosure	Power supply	Input type	Shipping weight	Wiring diagram
MS1PM12RT-1C	Panel 75x35	12 Vac/dc	A99	230 g	a)
MS1PM230T-1C	Panel 75x35	230 Vac	A99	300 g	c)
MS21PM12RT-1C	Panel 75x35	12 Vac	A99	230 g	b)
MS1DR230T-1C	DIN Rail	230 Vac	A99	340 g	d)
MS1PM12RV-1C	Panel 75x35	12 Vac	0-10 Volts	180 g	a)
MS1PM230V-1C	Panel 75x35	230 Vac	0-10 Volts	240 g	c)
MS1DR230V-1C	DIN Rail	230 Vac	0-10 Volts	290 g	d)

Note: Models with an A99 temperature input have a temperature sensor included

Two stages controls – MS2

This device is specifically designed for the control of two stages applications which can be in the following configuration:

- Two direct stages (cooling, dehumidifying,...) with common setpoint.
- Two reverse stages (heating, humidifying...) with common setpoint.
- Two stages with deadband, direct / reverse stage (heating/cooling, humidifying/dehumidifying..) with one setpoint.
- Two independent stages, one direct / one reverse, (heating/cooling, humidifying/dehumidifying..) with two setpoints.

Digital input functions

All controllers are equipped with an additional digital input. This input can perform the following functions:

- External alarm : If the input is open for a time longer than preset, all output goes OFF and an alarm message is displayed.
- Night setback: The setpoint are shifted of a preset value in order to save energy.
- Remote shut-OFF: In this case all output are shut-OFF and the display shows "OF". Key on the keypad.

Note: A detailed list of available parameters and their description can be found at the end of this documentation

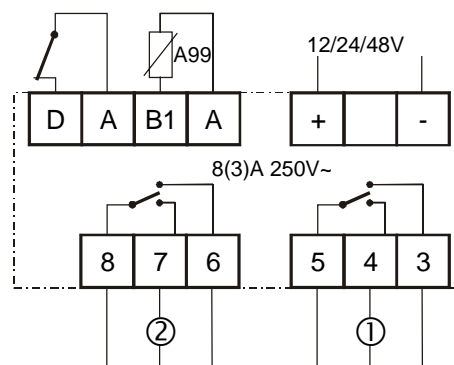

Wiring b)

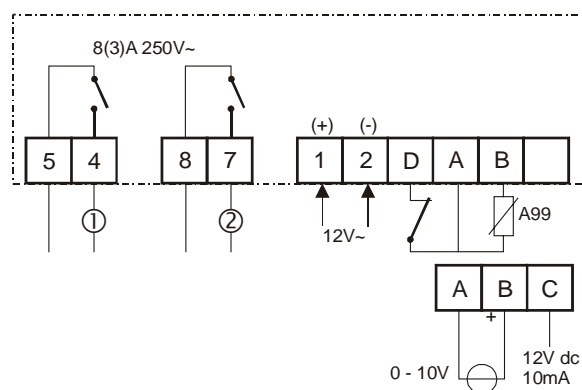

Wiring a)

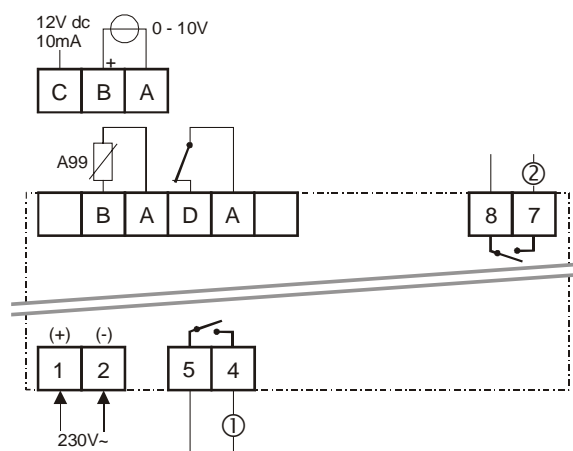

Wiring c)

Selection table

Item code	Enclosure	Power supply	Input type	Shipping weight	Wiring diagram
MS2PM12RT-1C	Panel 75x35	12 Vac/dc	A99	240 g	a)
MS2DR230T-1C	DIN Rail	230 Vac	A99	360 g	c)
MS2DR48DT-1C	DIN Rail	12-24 Vac/dc 48Vdc	A99	300 g	b)
MS2PM12RV-1C	Panel 75x35	12 Vac	0-10 Volts	180 g	a)
MS2DR230V-1C	DIN Rail	230 Vac	0-10 Volts	300 g	c)

Note: Models with an A99 temperature input have a temperature sensor included

Four stages controls – MS4

This control is specifically designed for the control of four stages temperature applications which can be in the following configuration:

- Four cooling stages with common setpoint.
- Four heating stages with common setpoint.
- Four stages with deadband, two heating stages / two cooling stages with common setpoint.
- Two independent sets of two dependent stages, two heating stages / two cooling stages

This control can be equipped with two sensors, one for the ambience and one for the outdoor. In this case it can perform energy saving functions by outdoor temperature compensation.

Digital input functions

All controllers are equipped with an additional digital input. This input can perform the following functions:

- External alarm: If the input is open for a longer time than preset, all output goes OFF and an alarm message is displayed.
- Night setback: The setpoint are shifted of a preset value in order to save energy.
- Remote shut-OFF: In this case all output are shut-OFF and the display shows "OF".

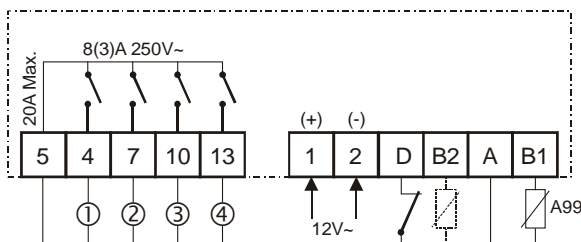

Wiring a)

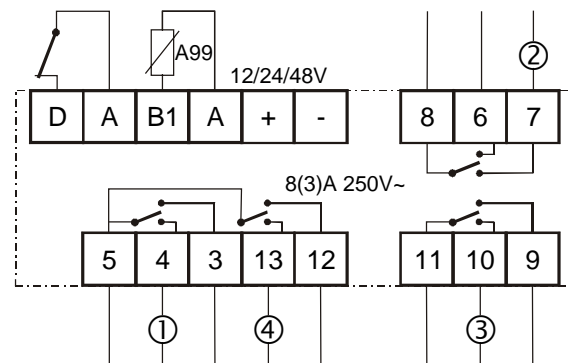

Wiring b)

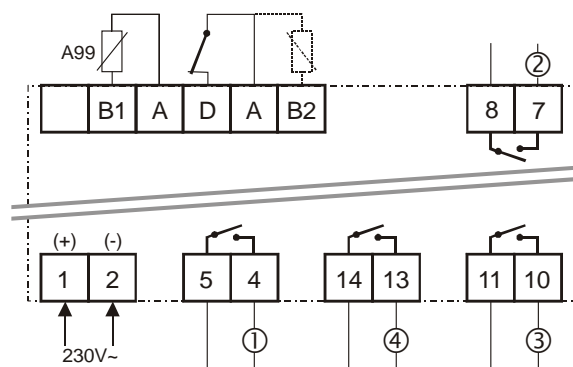

Wiring c)

Outdoor temperature compensation

This function is activated and configurable only when the second sensor is connected.

In this case, the controls perform a setpoint compensation based on the difference between outdoor temperature and the setpoint. You just need to fix the non compensated band, the heating and cooling compensation gain .

Note: A detailed list of available parameters and their description can be found at the end of this documentation.

Selection table:

Item code	Enclosure	Power supply	Input type	Shipping weight	Wiring diagram
MS4PM12RT-1C	Panel 75x35	12 Vac/dc	A99	270 g	a)
MS4DR230T-1C	DIN Rail	230 Vac	A99	400 g	b)
MS4DR48DT-1C	DIN Rail	12-24 Vac/dc 48Vdc	A99	400 g	c)

Note: Models have one temperature sensor included

Description of each parameter

Action modes:

This family of controllers allow the following type of predefined action modes:

One stage models MS1 and MSx1

One stage direct (1d)

One stage reverse (1r)

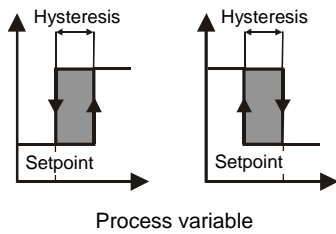

Process variable

Two stages models MS2

Two stages direct (2d)

Two stages reverse (2r)

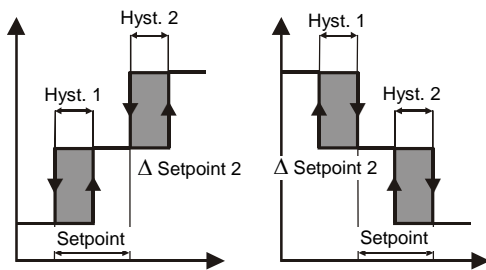

Process variable

Two independent stages (2i)

Two independent stages (2b)

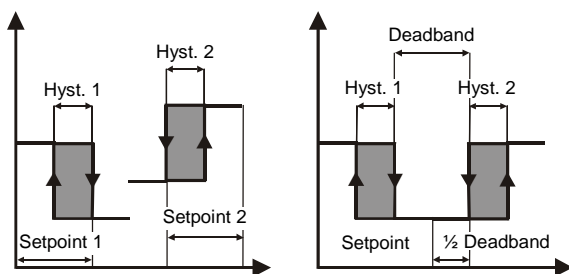

Process variable

Four stages models MS4

Four stages cooling (4d)

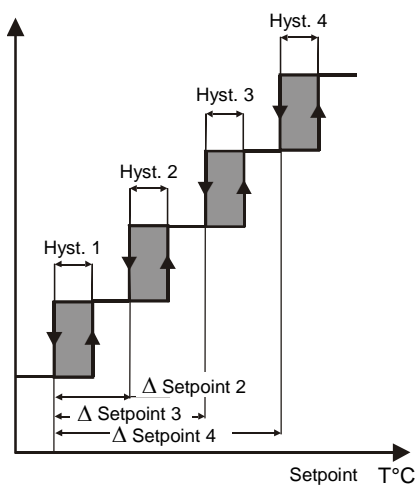

Setpoint T°C

Four stages heating (4r)

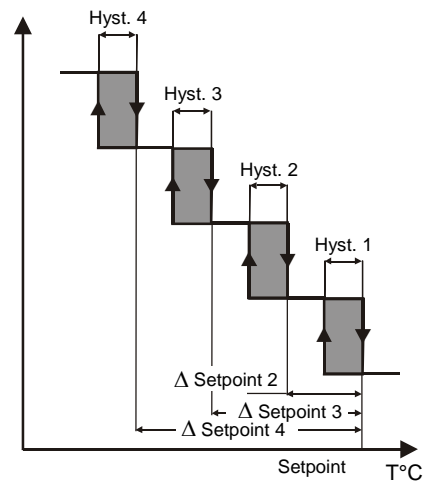

Setpoint T°C

Four stages with deadband (4b)

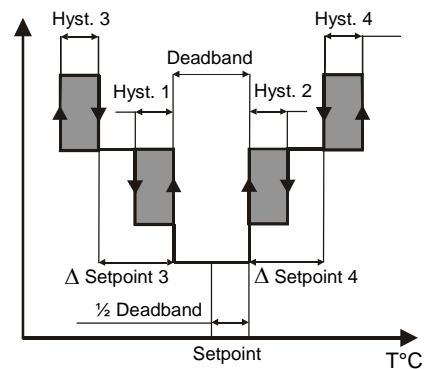

Setpoint T°C

Four independent stages (2 x 2) (4i)

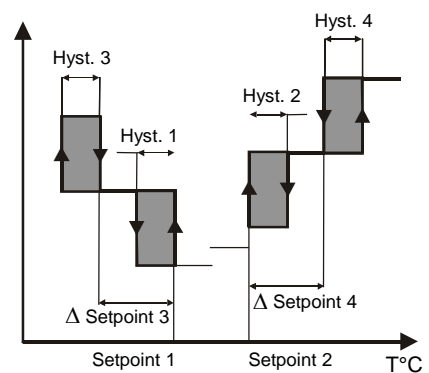

Setpoint 1 Setpoint 2 T°C

Description of each parameter

Setpoint

Definition depends on the action mode.
Please refer to the diagrams at the previous pages.

Hy1 Hysteresis

This is the difference between the value at which the output is switched OFF and the value at which the output is switched ON. This is an absolute value, related to the setpoint.

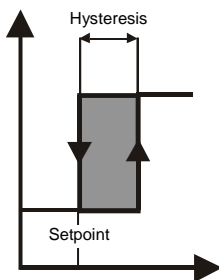

Example:
Cooling Setpoint = 6 °C
Hysteresis = 2 K
The compressor is switched ON when the temperature goes over 8 °C, and is turned OFF when the temperature decreases to 6 °C.

S2 Δ Setpoint 2

Switch OFF of output 2. Depending of the action mode it will have different meaning:
Mode 2d, 2r, 4d and 4r: differential to stage 1
Mode 2b and 4b: deadband
Mode 2i and 4i: independent setpoint 2

Hy2 Hysteresis

This is the difference between the value at which the output is switched OFF and the value at which the output is switched ON. This is an absolute value, related to the setpoint.

S3 Δ Setpoint 3

This is the differential between stage 3 and stage 1.

Hy3 Hysteresis

This is the difference between the value at which the output is switched OFF and the value at which the output is switched ON. This is an absolute value, related to the setpoint.

S4 Δ Setpoint 4

This is the differential between stage depending on the model, it refers to different setpoint:
Mode 4d and 4r: differential to stage 1
Mode 4b and 4i: differential to stage 2

Hy4 Hysteresis

This is the difference between the value at which the output is switched OFF and the value at which the output is switched ON. This is an absolute value, related to the setpoint.

LL/HL Lower & Upper setpoint limit

The setpoint value cannot be adjusted outside the limits defined by these parameters, to avoid improper setpoint setting by the user.

CC Anti short cycle protection, cooling

This parameter prevents the compressor from being turned ON / OFF too often. The value that you set is the minimum time between two subsequent switches ON of the output. It will be effective only on direct acting stages (i.e. cooling).

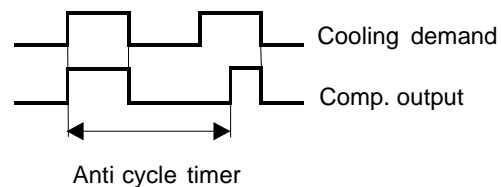

CH Anti short cycle protection, heating

Identical to the previous parameter but effective only on reverse acting stages (i.e. heating). This combination allows you to have a protection on stages driven by compressors and none on electrical coil stages.

rT Soft start

Allows you to increase or decrease the setpoint according to a time rate. The unit is minutes/units, in case of temperature input signal, it would be minutes/°C

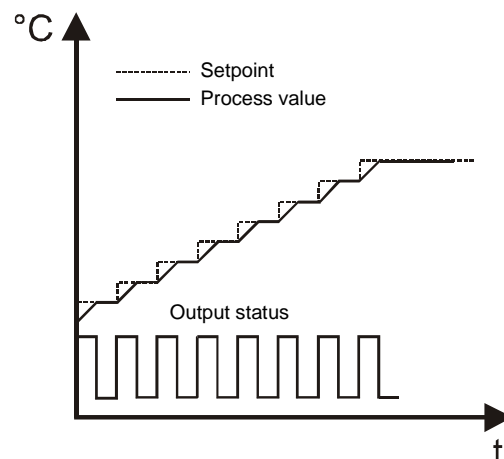

AH Maximum alarm

High alarm value relative to setpoint. If your setpoint is at 50% RH and you want an alarm 40% above setpoint, it will be triggered at 90%.

AL Minimum alarm

Low alarm value relative to setpoint. If your set point is at 6°C and you want an alarm 5 K below setpoint, it will be triggered at 1°C.

Ad Alarm differential

Useful to avoid alarm oscillation.

For example:

Setpoint = 6 °C

Max. temperature alarm = 5 K

Alarm differential = 2 K

In this case, when the cold room temperature goes over 6 + 5 = 11 °C for a time greater than parameter 16 the alarm is activated; when temperature returns below 6 + 5 - 2 = 9 °C the alarm is reset.

At Alarm time delay

Delay between the detection of the alarm and the activation of the alarm sequences. This is useful to prevent temporary conditions from causing an alarm. Furthermore, the controller automatically ignores the alarm condition "for 20 minutes after the power-ON".

So Sensor offset

This value is added to or subtracted from the measured value to compensate for possible field measurement offset errors. With the A99 sensor, to compensate for extra long copper cabling use the following formula:

$$\text{Compensation} = -\frac{5 \times \text{length}}{1000 \times \text{area}} \text{ K, where}$$

length = length of the cable in meters

area = section of the cable in millimetres and compensate for the calculated value.

Un Temperature units

(apply only to models with an A99 input)

0 = Celsius degrees,

1 = Fahrenheit degrees.

PU Display updating time delay

The process value display will be refreshed with this defined period. It will not affect the control performance.

iF Digital input function

The digital input (normally closed) can be configured according to the plant requirements:

0 = the DI is not connected

1 = If the contact is open for more a time longer than that set through parameter 22, the plant is switched OFF and an alarm message is displayed

2 = Stand-by bias. When the contact is open the setpoint(s) are shifted of the value set in parameter 21. Reverse setpoints (heating, humidifying) are decreased, direct setpoints (cooling, dehumidifying) are increased.

3 = Remote shut-off of the plant. When the contact is open, the plant is stopped.

Sb Stand-by bias

Value of the setpoint shift when the Digital input is open and configuration of parameter 20 = 2

Id Digital input time delay

Time between the detection of the digital input opening and the enabling of the function selected through parameter 20.

The following parameters are dedicated to temperature compensation and are available only when the second temperature sensor (AI2) is connected.

The compensation can only perform energy saving type and is calculated based on the difference between external temperature and setpoint. Its parameters are the following

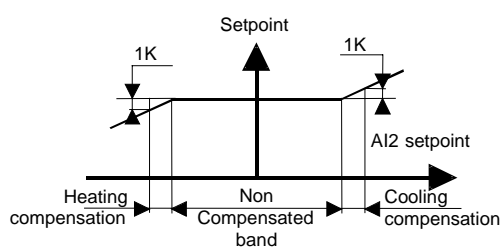
**Lc Non compensated band**

This is the band of temperature difference (outside temperature - setpoint) where no compensation is performed.

Uc Heating compensation

This is the decreasing rate of compensation when: (outside temperature - setpoint) gets below half of the non compensated band. It is given in Kelvin / Kelvin (Amount of outside temperature decrease to reduce the setpoint by 1K)

nc Cooling compensation

This is the increasing rate of compensation when: (outside temperature - setpoint) gets above half of the non compensated band. It is given in Kelvin / Kelvin (Amount of outside temperature increase to increase the setpoint by 1K)

IS Interstage delay

This is the time delay between switching ON of 2 or more successive stages. It prevents a high inrush current when there is a request for cooling or heating and more stages should switch ON simultaneously. It is active between stages of the same type (i.e. cooling stages) and is only active during switch ON.

Lr Low range analog input 1

(apply only to models with 0 to 10 Volt input). This is the value at 0.0 Volt dc when input 1 is used with 0-10 Volts signal.

Hr High range analog input 1

(apply only to models with 0 to 10 Volt input). This is the value at 10.0 Volt dc when input 1 is used with 0-10 Volts signal.

Parameters

	Parameter	Setting Range	Default	MS1 MSx1	MS2	MS4
Temperature control parameters						
H1	Hysteresis (HY)	1 to 9 K	2	•	•	•
S2	Δ Setpoint 2	Direct/Reverse = 1 to 40 units Deadband = 2 to 40 units Indip. setpoint = Low to high limit	3		•	•
H2	Hysteresis (HY)	1 to 9 K	-40		•	•
S3	Δ Setpoint 3	1 to 40 units	-40			•
H3	Hysteresis (HY)	1 to 9 K	-40			•
S4	Δ Setpoint 4	1 to 40 units	-40			•
H4	Hysteresis (HY)	1 to 9 K	-40			•
LL	Lower setpoint limit (LL)	-40°C to higher limit	-40	•	•	•
HL	Higher setpoint limit (HL)	lower limit to 125 units	70	•	•	•
CC	Anti short cycling cooling (CC)	0 to 9 min	2	•	•	•
CH	Anti short cycling heating (CH)	0 to 99 min	60	•	•	•
rt	Soft start	0 to 99 min / units	3	•	•	•
Alarm parameters						
AH	High. temperature alarm	0 to 50 units related to setpoint	10	•	•	•
AL	Low temperature alarm	-50 to 0 units related to setpoint	-10	•	•	•
Ad	Alarm differential	1 to 9 units	1	•	•	•
At	Alarm time delay	0 to 99 min	30	•	•	•
Temperature parameters						
Lc	Non compensated band	0 to 20 K	OF			•
Uc	Heating compensation	0 to 6 K/K	0			•
nc	Cooling compensation	0 to 6 K/K	20			•
Other parameters						
So	Sensor offset	-20 to +20 units	0	•	•	•
Un	Temperature units	0 = Celsius degrees 1 = Fahrenheit degrees	0	•	•	•
PU	Display updating time delay	1 to 99 sec	7	•	•	•
iF	Digital input function	0 = Not used 1 = Shut off and alarm signalling 2 = Stand by mode 3 = Remote switch off	6		•	•
Sb	Stand-by bias	0 to 20 units	40		•	•
Id	Digital input time delay	0 to 99 sec	5		•	•
IS	Interstage delay	3 to 99 sec	20		•	•
Lr	Low range analog input 1	-40 to high range	20	•	•	
Hr	High range analog input 1	Low range to 100	20	•	•	

* When there are 2 setpoints (MS2 or MS4 is configured for independent setpoint mode), the low alarm is linked to the lowest setpoint and the high alarm is linked to the highest setpoint.

Accessories

Item Code	Description
TR230/12-1	Transformer 230 / 12,3 VA
A99BB-200C	Sensor, cable length: 2m

For humidity or pressure sensors refer to HT9 or P99 Product Data Sheets.

Repair and replacement

Field repair is not possible. In case of defective or improperly functioning control, please check with your nearest supplier. When contacting the supplier for replacement, you should state the type-model number of the control. This number can be found on the data plate.

Notes

Specifications

Power Requirements	12 Vac/dc $\pm 10\%$ (Models with 0 to 10 V input 12 Vac $\pm 10\%$) 230 Vac $\pm 10\%$ (only MSxDR48DT) 12-24 Vac/dc $\pm 10\%$ – 48 Vdc $\pm 10\%$	Not all power supplies are available in every version. Please refer to selection tables.			
Frequency	50/60 Hz				
Power consumption	DIS : 1.5 VA MS : 2 VA				
Protection Class	Panel mount	Front panel	IP 54		
		Rear	IP 20		
	DIN rail	IP 20			
Ambient Operating Conditions	-10° to +55 °C (14° to 131 °F)				
Range	0 to 95 % RH (non condensing)				
	-40 to +70 °C -40 to 100 when 0-10 Volts input				
Accuracy & Precision	± 1 unit				
Sensor cable	2 meters with temperature input None when 0 to 10 Volt input				
Output ratings (250V ac)	Stage 1	Stage 2	Stage 3 & 4	Alarm	
	MS1PM12	SPST 8(3)A		o.c(*)	
	MS21PM12	SPST 16(12)A		o.c(*)	
	MS1PM230	SPDT 8(3)A		o.c(*)	
	MS1DR230	SPST 8(3)A		o.c(*)	
	MS2PM12	SPST 8(3)A	SPST 8(3)A		
	MS2DR48	SPDT 8(3)A	SPDT 8(3)A		
	MS2DR230	SPST 8(3)A	SPST 8(3)A		
	MS4PM12RT-1C	SPST 8(3)A	SPST 8(3)A	SPST 8(3)A	
	MS4DR230T-1C	SPST 8(3)A	SPST 8(3)A	SPST 8(3)A	
	MS4DR48DT	SPDT 8(3)A	SPDT 8(3)A	SPDT 8(3)A	
	(*) Open collector:	40 Vdc/100 mA			
Dimensions (H x W x D)	Panel mount	35 x 75 x 68 (1.38" x 2.95" x 2.68")			
	DIN rail	118 x 70 x 52.5 (4.65" x 2.76" x 2.07")			
CE Compliance	73/23/EEC directive: EN60730 89/336/EEC directive: EN50082-1 EN50082-2				

The performance specifications are nominal and conform to acceptable industry standards. For applications at conditions beyond these specifications, consult the local Johnson Controls office or representative. Johnson Controls shall not be liable for damages resulting from misapplication or misuse of its products. This document is subject to change without prior notice.

**JOHNSON
CONTROLS**

Johnson Controls International, Inc.

Headquarters: Milwaukee, WI, USA
 European Headquarters: Westendhof 8, 45143 Essen, Germany
 European Factories: Lomagna (Italy), Leeuwarden (The Netherlands), Essen (Germany)
 Branch Offices: Principal European Cities.
 This document is subject to change without notice