

SUCTION LINE ACCUMULATORS

The primary function of a Suction Line Accumulator is to prevent a sudden surge of liquid refrigerant, or oil, from returning down the suction line and into a compressor. The suction line accumulator is a temporary reservoir for liquid refrigerant and oil.

The accumulator is designed to meter both the liquid refrigerant and oil back to the compressor at a controlled rate. This prevents compressor damage. By metering the liquid refrigerant and oil back to the compressor, the accumulator also helps maintain system efficiency and proper crankcase oil levels. Both horizontal and vertical suction line accumulators are available. Heat Exchanger (HE) and Heat Pump models (HP) are also available.

Applications

Suction line accumulators are installed in air conditioning and refrigeration systems where a sudden return of liquid down the suction line is possible. The product range is designed for use with HCFC and HFC refrigerants, along with their associated oils.

How it works

Refrigerant vapour from the evaporator enters the suction line accumulator, along with any liquid refrigerant or oil. The outlet side of each accumulator is designed to allow refrigerant vapour to return to the compressor. For a horizontal vessel, the position of the outlet connection ensures vapour return. For a vertical vessel, vapour return is achieved by a special U tube arrangement. On certain models, a tube within a tube arrangement is used as an alternative. Liquid is held at the bottom of the accumulator ready for metering back to the compressor.

For horizontal accumulators, liquid is metered to the compressor via a dip tube. For vertical models, liquid is metered to the compressor via a screened orifice at the bottom of the tube. The vapour carries the metered liquid back to the compressor. Metering of liquid only occurs when the compressor is running.

Main features

- Prevents liquid slugging
- Controlled liquid return
- Large flow capacity
- Low pressure drop
- Screen protected orifice on vertical models
- Heat exchanger and Heat pump options

Technical Specification

S-76 series:

MWP = 20.8 barg @ +100°C

S-704 series (all models), S-7061-CE to S-7065-CE (except HE models), S-7721-CE & S-7725-CE (except HE models):

MWP = 31 barg @ +100°C

S-705 series (all models), S-7061-CE to S-7065-CE (HE models), all other S-77 series models :

MWP = 31 barg @ +130°C

Note: For all models, a de-rated MWP applies for operating temperatures below -10 °C. For further information, please contact Henry Technologies.

Materials of Construction

The shell and end caps are made from carbon steel. Branch connections are made from steel or copper.



SUCTION LINE ACCUMULATORS

Part No	Conn Size (inch)	Dimensions (mm)						Mounting Details	Weight (kg)	CE Cat
		Ø A	B	C	D	E	F			
S-7615-CE	1 5/8 ODS	152	711	546	99	762	812	4 x Ø12.7mm Slots	13	Cat II
S-7621-CE	2 1/8 ODS	152	933	768	100	984	1035	4 x Ø12.7mm Slots	17	Cat II
S-7625-CE	2 5/8 ODS	152	1270	1105	105	1320	1371	4 x Ø12.7mm Slots	21	Cat II

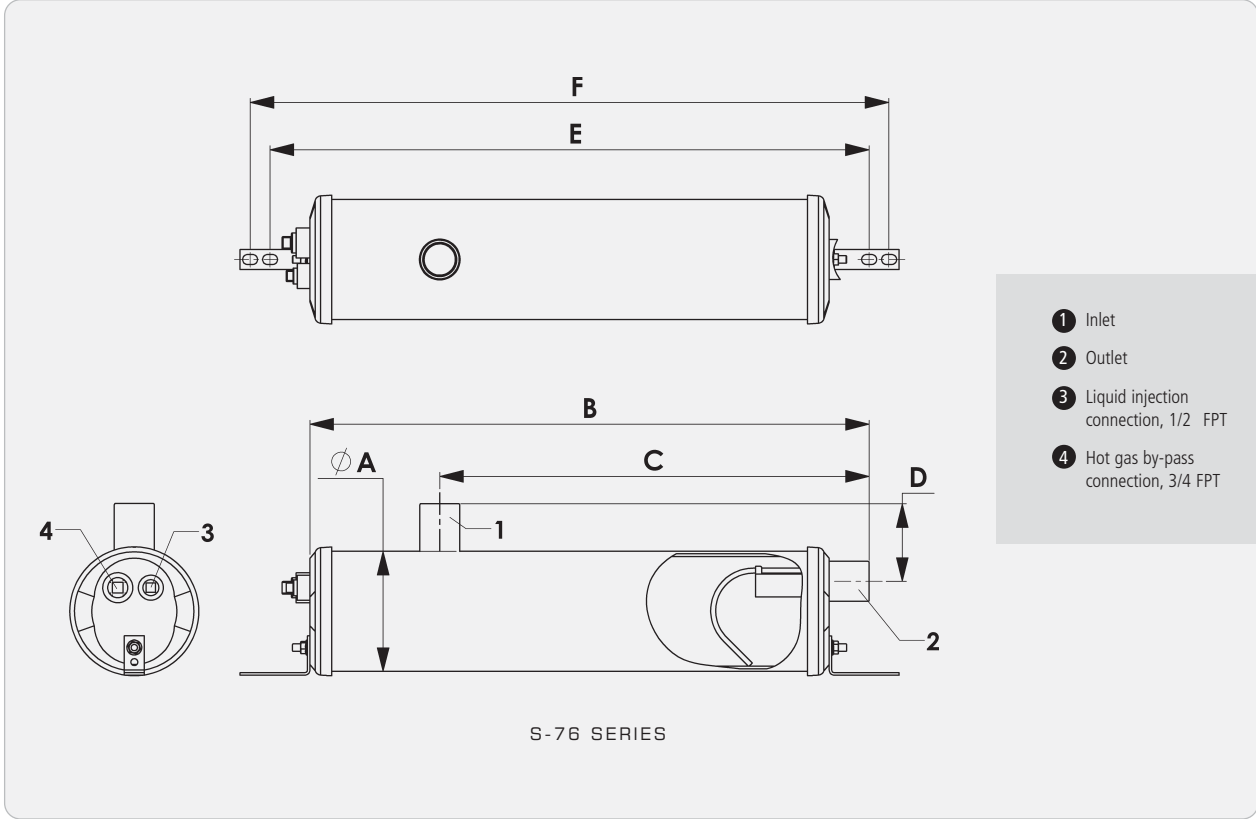

Part No	Conn Size (inch)		Dimensions (mm)					Mounting details	HE Coil Conn Size (inch)	Drawing Reference	Weight (kg)	CE Cat	
			A	B	C	D	E (Ø)						
S-7043	-	-	5/8 ODS	102	168	48	N/A	N/A	3/8-16 stud & nut	N/A	fig.1	2	SEP
S-7044	-	S-7044-HP	1/2 ODS	102	264	48	N/A	N/A	3/8-16 stud & nut	N/A	fig.1	2.5	SEP
S-7045	-	S-7045HP	5/8 ODS	102	264	48	N/A	N/A	3/8-16 stud & nut	N/A	fig.1	2.5	SEP
-	S-7045HE	-	5/8 ODS	102	264	64	64	N/A	3/8-16 stud & nut	3/8 ODS	fig.1	2.5	SEP
S-7046	-	S-7046HP	3/4 ODS	102	270	48	N/A	N/A	3/8-16 stud & nut	N/A	fig.1	2.5	SEP
-	S-7046HE	-	3/4 ODS	102	270	64	64	N/A	3/8-16 stud & nut	3/8 ODS	fig.1	2.5	SEP
S-7057-CE	S-7057HE-CE	S-7057HP-CE	7/8 ODS	127	330	57	70	N/A	3/8-16 stud & nut	1/2 ODS	fig.1	5	CAT I
S-7061-CE	S-7061HE-CE	S-7061HP-CE	1 1/8 ODS	152	381	76	73	N/A	M10 or 3/8-16 stud & nut	5/8 ODS	fig.1	8	CAT I
S-7063-CE	S-7063HE-CE	S-7063HP-CE	1 3/8 ODS	152	630	76	73	N/A	M10 or 3/8-16 stud & nut	5/8 ODS	fig.1	12	CAT II
S-7065-CE	S-7065HE-CE	S-7065HP-CE	1 5/8 ODS	152	630	76	73	N/A	M10 or 3/8-16 stud & nut	3/4 ODS	fig.1	13	CAT II
S-7721-CE	-	-	2 1/8 ODS	219	588	89	140	282	3 Ø14mm x 22mm slots	N/A	fig.2	22	CAT II
-	S-7721HE-CE	-	2 1/8 ODS	219	588	89	140	282	3 Ø14mm x 22mm slots	7/8 ODS	fig.3	22	CAT II
S-7722-CE	-	-	2 1/8 ODS	219	588	89	140	282.7	3 Ø14mm x 22mm slots	N/A	fig.2	22	CAT II
-	S-7722HE-CE	-	2 1/8 ODS	219	588	89	140	282.7	3 Ø14mm x 22mm slots	7/8 ODS	fig.3	22	CAT II
S-7725-CE	-	-	2 5/8 ODS	273	578	118	140	338.5	3 Ø14mm x 22mm slots	N/A	fig.2	34	CAT II
-	S-7725HE-CE	-	2 5/8 ODS	273	578	118	140	338.5	3 Ø14mm x 22mm slots	1 3/8 ODS	fig.3	34	CAT II
S-7726-CE	-	-	2 5/8 ODS	273	578	118	140	336.6	3 Ø14mm x 22mm slots	N/A	fig.2	34	CAT III
-	S-7726HE-CE	-	2 5/8 ODS	273	578	118	140	336.6	3 Ø14mm x 22mm slots	1 3/8 ODS	fig.3	34	CAT III
S-7731-CE	-	-	3 1/8 ODS	324	635	140	149	387.4	3 Ø14mm x 22mm slots	N/A	fig.2	50	CAT III
-	S-7731HE-CE	-	3 1/8 ODS	324	635	140	149	387.4	3 Ø14mm x 22mm slots	1 3/8 ODS	fig.3	50	CAT III
S-7732-CE	-	-	3 1/8 ODS	324	635	140	149	387.4	3 Ø14mm x 22mm slots	N/A	fig.2	50	CAT III
-	S-7732HE-CE	-	3 1/8 ODS	324	635	140	149	387.4	3 Ø14mm x 22mm slots	1 3/8 ODS	fig.3	50	CAT III
S-7741-CE	S-7741HE-CE	-	4 1/8 ODS	406	902	279	368	470	3 Ø14mm x 22mm slots	2 5/8 ODS	fig.4	102	CAT III
S-7742-CE*	-	-	4 1/8 ODS	508	1130	330	N/A	457.2	4 Ø16.3mm holes on square base	N/A	fig.4*	130	CAT IV

*S-7742-CE features a square mounting plate - not mounting brackets

Notes (to be read in conjunction with drawing legend):-
 For liquid level switch and relief valve connection positions, see notes below for relevant models
 1. S-7722, S-7722HE & S-7726 models
 2. S-7726HE, S-7732, S-7732HE, S-7741, S-7741HE & S-7742 models
 3. S-7741HE model
 4. S-7741 & S-7742 models

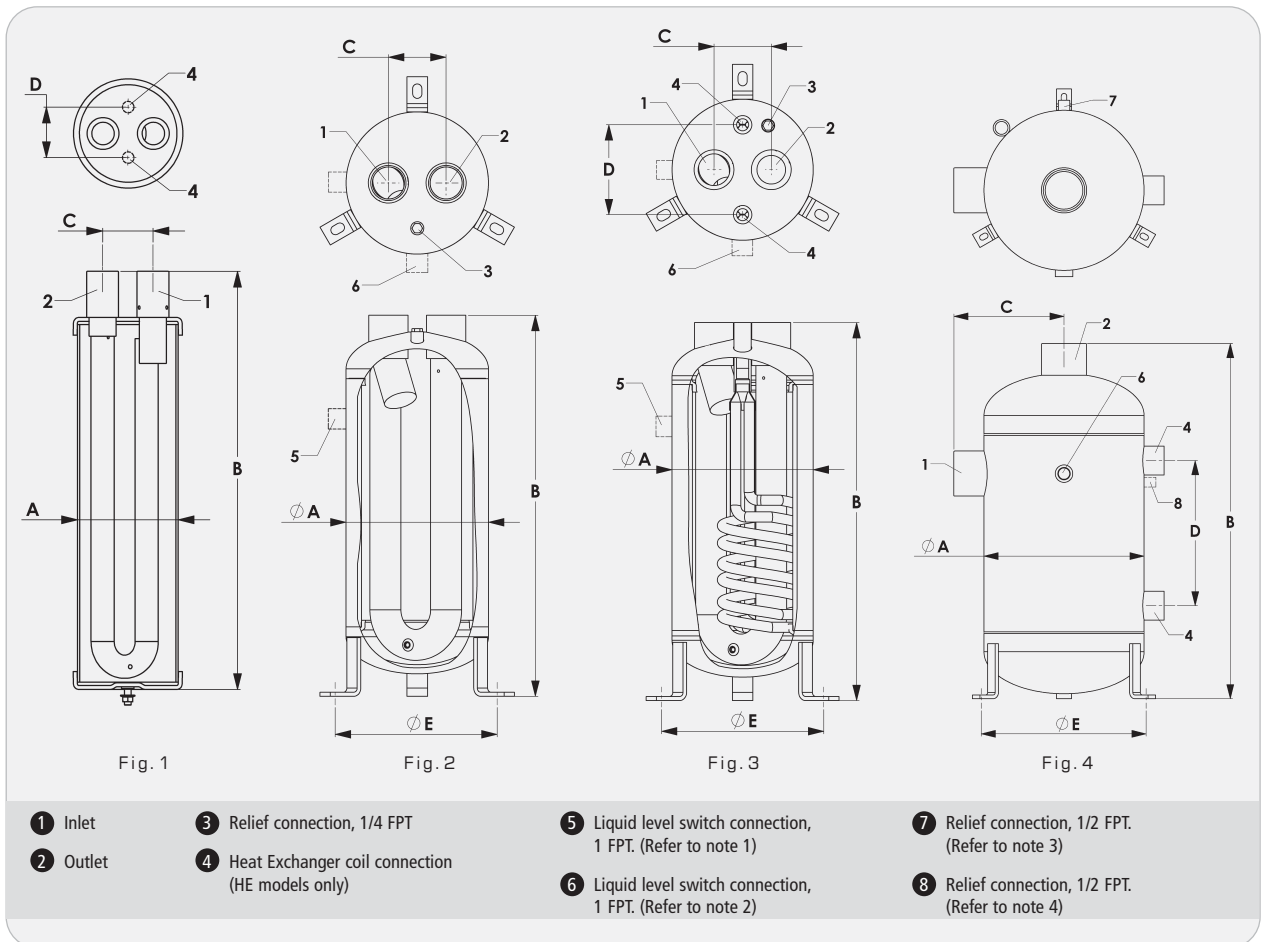

SUCTION LINE ACCUMULATORS

Part No	Refrigerant Holding Capacity (kg at -18°C)			Recommended kW of refrigerant at Suction Evaporating Temp (°C)																					
	R134a	R22	R404A																						
				R134a					R22					R404A / R507											
	5°	-7°	-18°	-29°	-40°	5°	-7°	-18°	-29°	-40°	5°	-7°	-18°	-29°	-40°										
S-7615-CE	10.6	10	8.8	MAX	53	35	Horizontal accumulators not suitable for applications below -10°C					102	70	Horizontal accumulators not suitable for applications below -10°C					100	57	Horizontal accumulators not suitable for applications below -10°C				
S-7621-CE	14.4	13	11.9	MAX	101	69	Horizontal accumulators not suitable for applications below -10°C					176	106	Horizontal accumulators not suitable for applications below -10°C					173	117	Horizontal accumulators not suitable for applications below -10°C				
S-7625-CE	21.2	19	17.6	MAX	176	123	Horizontal accumulators not suitable for applications below -10°C					334	229	Horizontal accumulators not suitable for applications below -10°C					328	217	Horizontal accumulators not suitable for applications below -10°C				
S-7043	1	1	0.7	MAX	3.2	2.3	1.5	1	0.6	6.3	4.5	3.1	2.1	1.3	6.3	4.3	2.8	1.8	1.1						
				MIN	0.7	0.6	0.5	0.4	0.3	0.9	0.8	0.7	0.6	0.7	0.9	0.7	0.6	0.5	0.4						
S-7044	2	1.9	1.7	MAX	1.6	1.2	0.8	0.5	0.6	3.2	2.3	1.6	1.0	0.7	3.1	2.2	1.5	0.9	0.6						
				MIN	0.3	0.2	0.2	0.2	0.1	0.5	0.4	0.3	0.2	0.2	0.5	0.3	0.3	0.2	0.2						
S-7045	2	1.9	1.7	MAX	3.2	2.3	1.5	1	0.6	6.4	4.5	3.1	2.1	1.3	6.3	4.3	2.8	1.8	1.1						
				MIN	0.7	0.6	0.5	0.4	0.3	0.9	0.8	0.7	0.6	0.4	0.9	0.7	0.6	0.5	0.4						
S-7046	2	1.9	1.7	MAX	4.5	3.1	2.1	1.4	0.8	8.8	6.2	4.2	2.8	1.8	8.7	5.9	3.8	2.5	1.5						
				MIN	0.9	0.7	0.6	0.5	0.4	1.2	1	0.8	0.7	0.6	1.3	1	0.8	0.6	0.5						
S-7057-CE	4.2	3.9	3.5	MAX	7.7	5.4	3.6	2.3	1.4	15.2	10.7	7.1	4.7	3	14.9	10.2	6.5	4.2	2.6						
				MIN	1.3	1.1	0.9	0.7	0.6	1.8	1.6	1.3	1.1	0.9	1.8	1.5	1.2	1	0.7						
S-7061-CE	5.8	5.4	4.9	MAX	16.3	11.4	7.3	4.8	2.9	32	22.8	14.4	9.7	6.1	31.4	21.7	13.2	8.6	5.2						
				MIN	2.1	1.8	1.5	1.2	1	3	2.5	2.2	1.8	1.4	2.9	2.4	2	1.6	1.2						
S-7063-CE	9.9	9.1	8.3	MAX	27.8	18.8	12	7.6	4.7	54.9	37.7	23.8	15.6	10	53.9	35.9	21.8	13.8	8.6						
				MIN	4.4	3.7	3.1	2.5	2	6.1	5.1	4.4	3.6	2.9	6	4.9	4	3.2	2.5						
S-7065-CE	9.9	9.1	8.3	MAX	49.3	33.8	21.1	13.4	8.2	96.8	67.6	41.5	27.4	17.5	95	64.1	38	24.3	15						
				MIN	7.6	6.3	5.3	4.4	3.5	10.5	8.8	7.6	6.4	5.1	10.3	8.4	7	5.7	4.4						
S-7721-CE	14.7	13.6	12.3	MAX	109	70.4	49.3	26.4	17.6	204	141	91.5	63.4	42.2	201	134	84.5	56.3	35.2						
				MIN	14.1	12.3	10.6	8.8	7	21.1	19.4	15.8	14.1	10.6	21.1	17.6	14.1	12.3	8.8						
S-7722-CE	14.7	13.6	12.3	MAX	109	70.4	49.3	26.4	17.6	204	141	91.5	63.4	42.2	201	134	84.5	56.3	35.2						
				MIN	14.1	12.3	10.6	8.8	7	21.1	19.4	15.8	14.1	10.6	21.1	17.6	14.1	12.3	8.8						
S-7725-CE	22	20	18.2	MAX	172	113	75.7	42.2	22.9	313	215	144	98.6	54.6	308	204	132	88	47.5						
				MIN	21.1	19.4	15.8	12.3	3.5	31.7	29.9	24.6	22.9	5.3	31.7	28.2	22.9	21.1	5.3						
S-7726-CE	22	20	18.2	MAX	172	113	75.7	42.2	22.9	313	215	144	98.6	54.6	308	204	132	88	47.5						
				MIN	21.1	19.4	15.8	12.3	3.5	31.7	29.9	24.6	22.9	5.3	31.7	28.2	22.9	21.1	5.3						
S-7731-CE	36.4	33.2	30	MAX	253	194	130	84.5	33.4	465	324	215	141	82.7	456	308	197	125	70.4						
				MIN	35.2	31.7	24.6	22.9	5.3	54.6	45.8	40.5	33.4	8.8	52.8	44	37	29.9	8.8						
S-7732-CE	36.4	33.2	30	MAX	253	194	130	84.5	33.4	465	324	215	141	82.7	456	308	197	125	70.4						
				MIN	35.2	31.7	24.6	22.9	5.3	54.6	45.8	40.5	33.4	8.8	52.8	44	37	29.9	8.8						
S-7741-CE	62	61	55	MAX	401	259	156	107	69.7	792	510	306	211	137	757	503	320	201	116						
				MIN	109	89.4	75.7	59.8	47.2	151	125	109	86.6	31.7	174	113	73.9	45.8	24.6						
S-7742-CE	127	126	114	MAX	401	259	156	107	69.7	792	510	306	211	137	757	503	320	201	116						
				MIN	109	89.4	75.7	59.8	47.2	151	125	109	86.6	31.7	174	113	73.9	45.8	24.6						

Selection Guidelines

The accumulator should have adequate holding capacity. Normally, this should not be less than 50% of the total system charge.

The system designer should check that the minimum and maximum system refrigeration capacities are within the limits of the accumulator.

The recommended minimum and maximum kW capacities are listed in the table. The maximum kW capacities are based on accumulator pressure loss and oil return. The pressure loss is equivalent to 1/2°C. The minimum kW capacities are to ensure proper oil return.

Example:

Refrigerant R404A

System maximum refrigeration capacity = 170 kW

System minimum refrigeration capacity = 65 kW

Evaporating temperature = -18°C

System Charge = 55 kg

Recommended accumulator is model S-7731-CE with a refrigerant holding capacity of 30 kg and a minimum/maximum rating of 37/197 kW.

Additional selection information

The heat exchanger models can be used on low temperature systems to sub-cool the liquid line while helping to boil off liquid refrigerant in the accumulator by passing the liquid line through the heat exchanger coil. This can increase system efficiency while helping oil flow in the suction line. Do not use discharge gas through the heat exchange coil as there is a risk of overheating the compressors.

Heat pump systems must use the HP accumulator models. Winter heating can cause too much liquid refrigerant to slug back to the compressor. Heat pump accumulators incorporate a smaller orifice to prevent excessive liquid flow.

Two accumulators can be piped in series to increase holding capacity. Oil will be metered from one accumulator to the next to ensure proper oil flow to the compressors. Adding a second identical accumulator will effectively double the holding capacity of a single accumulator.

Piping two identical accumulators in parallel will double the kW capacity. Two identical accumulators must be used.

On low temperature systems (-18°C and below) a heater band should be installed to help boil off the liquid refrigerant and aid oil flow. Do not add too much heat or there is a risk of overheating the compressors.

Horizontal accumulators should not be used when the liquid refrigerant temperature is less than -10°C.

Installation – Main issues

1. Install the accumulator after the suction line filter.
2. A fusible plug is fitted to the bottom of the vessel on series S-70 HE models. For all other models, a pressure relief device connection is provided at the top of the vessel. The user must ensure that the vessel is protected from over-pressure. Over-pressure will occur if the liquid refrigerant is evaporated e.g. external fire case.
3. Heater bands should be installed at the bottom of a vertical accumulator and at the outlet end of a horizontal accumulator.