

ROBINAIR VACUUM PUMPS

Overview



Robinair Vacuum Pumps are engineered specifically to meet your HVAC/R maintenance needs and to give you trouble-free operation. Take advantage of Robinair's years of experience and know-how developing pumps to help you do your job faster and better.

COOLTECH™ AND VACUMASTER™ FEATURES

- Two Stage Design – second stage starts pumping at a lower pressure to pull a deeper ultimate vacuum
- Integral Check Valve – prevents pump oil from being sucked into the system if a power loss occurs
- Die-Cast Aluminium housing – lightweight but durable
- Molded Base – Durable polycarbonate base improves pump balance and minimizes vibration

ADDITIONAL COOLTECH™ FEATURES

- Offset Rotary Vanes – Our proven design creates the deep vacuum conditions needed for a thorough evacuation
- Gas Ballast feature – helps keep the pump oil clean by reducing condensation of moisture
- Iso-Valve™ – isolates pump from the system with just a 1/4 turn, making it simple to measure rate of rise

Oil Fill Port – Makes adding oil simple since the port is accessible from the front or either side. The sight glass on the front of the pump shows you when enough oil has been added.

Heavy-Duty Motor – High torque design for easy start-up and efficient operation.

Offset Rotary Vanes – Our proven design builds a powerful compression within the pumping chamber to reduce system pressure and vaporize moisture so it can be exhausted along with air.

Molded Base – Durable polycarbonate base improves pump balance and minimizes vibration during operation.

Gas Ballast – Moisture laden air passing through the pump mixes with relatively dry air to such a degree that compression does not cause condensation

Iso-Valve™ – Isolates the pump from the system with just a quarter-turn.

Die-cast Aluminium Housing – Cast aluminium housings make the pumps lightweight but durable.

Two Stage Design – Cleans the system more thoroughly than a single-stage pump; the second stage starts pumping at a lower pressure so you can pull a deeper, ultimate vacuum.

Oil Drain Valve – Positioned at the bottom of the oil reservoir and angled for faster, more complete draining.

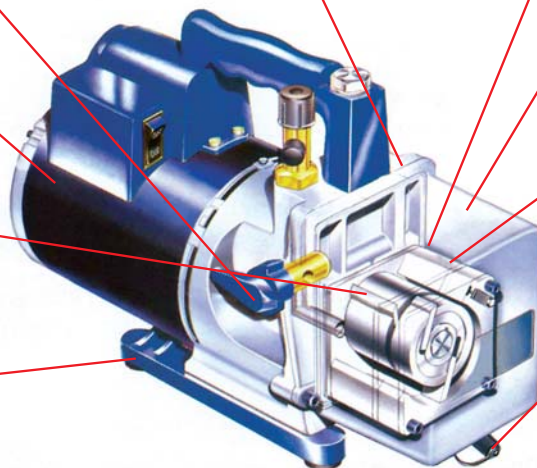

ROBINAIR VACUUM PUMPS

ROBINAIR Vacuum Pumps at Top Quality

Model 15401 - 4 CFM



Specifications	Model 15401 - 4 CFM
Capacity	93 l/min.
No. of Stages	2
Endvacuum	20 Micron
Intake Fittings UNF	1/4" MFL + 1/2" MFLT
Oil Capacity	445 ml (15 oz)
Motor Size	244 W (1/3 HP)
Power Supply	230 V, 50 Hz / 115 V, 60 Hz
Weight	12,2 kg (27 lbs)
Dimensions	24,7 x 14,25 x 38,1 cm (9,5" x 5,5" x 15")

RA 15401

ROBINAIR Vacuum Pumps at Top Quality

Model 15601 - 6 CFM



Specifications	Model 15601 - 6 CFM
Capacity	142 l/min
No. of Stages	2
Endvacuum	20 Micron
Intake Fittings UNF	1/4" MFL + 1/2" MFLT
Oil Capacity	445 ml (15 oz)
Motor Size	366 W (1/2 HP)
Power Supply	230 V, 50 Hz / 115 V, 60 Hz
Weight	12,2 kg (27 lbs)
Dimensions	24,7 x 14,25 x 38,1 cm (9,5" x 5,5" x 15")

RA 15601

ROBINAIR Vacuum Pumps at Top Quality

Model 15225 - 1,2 CFM



Specifications	Model 15225 - 1,2 CFM
Capacity	28 l/min.
No. of Stages	2
Endvacuum	50 Micron
Intake Fittings UNF	1/4" MFL
Oil Capacity	148 ml
Motor Size	92 W (1/8 HP)
Power Supply	230 V, 50 Hz
Weight	4,5 kg (9,9 lbs)
Dimensions	11,4 x 25 x 21,6 cm (4,5" x 9,8" x 8,5")

RA 15225



ROBINAIR VACUUM PUMPS

The Additional New Generation of ROBINAIR Vacuum Pumps

ROBINAIR VacuMaster Model 15301-E/15501-E

- The additional new generation of ROBINAIR vacuum pumps
- Built with Robinair's proven offset rotary vane for fast, thorough evacuation
- High pumping capacity reduces evacuation time

Specifications	Model 15301-E	Model 15501-E
Capacity	71 l/min	118 l/min
No. of Stages	2	2
Endvacuum	40 Mikron	40 Mikron
Intake Fittings UNF	1/4" SAE - 3/8" SAE	1/4" SAE - 3/8" SAE
Oil Capacity	220 ml (7.5 oz)	220 ml
Motor Size	1/3 HP (244 W)	1/3 HP (244 W)
Power Supply	230 V 50 Hz	230 V 50 Hz
Weight	10 kg (22 lbs)	12,5 kg (27,5 lbs)
Dimensions	255 x 123 x 385 mm (10" x 4,8" x 15,1")	255 x 123 x 385 mm (10" x 4,8" x 15,1")



RA 15301-E



RA 15501-E

- Best performance and quality at fair prices
- Including Vacuum Gauge
- Solenoid Valve for keeping the vacuum when power loss occurs
- Including one bottle of vacuum pump oil



ROBINAIR POCKET-ROBI GOLD

Robinair's NEW Pocket-Robi GOLD is designed specifically for A/C service. This NEW ultra-compact pump is extremely small and has no electric motor. It is operated by any hand drill up to a maximum of 2000RPM. When used with a cordless (battery operated) drill, the Pocket-Robi GOLD can be used in areas without AC power available. Thus the Pocket-Robi GOLD is not only the world's smallest vacuum pump, but also the world's most portable and convenient. For any application with restricted access, this is the ideal tool to use!

Specifications	
Displacement	4 Liters/Minute @ 1000RPM; Maximum 8L/min @ 2000RPM
Ultimate Vacuum	400 Microns
Intake Fitting	5/16" MFL (UNF 1/2-20)
Maximum Operating Cycle	30 minutes
Oil Capacity	6 ml
Weight	500 grams
Dimensions H x W x D	82 x 62 x 55 mm

Comes shipped with 30 ml of Robinair Premium Vacuum Pump Oil (RA 15800 GDP-3 Oil)



RA 15800GDP

