



DATA BOOK

VRF INVERTER MULTI-SYSTEM AIR-CONDITIONERS (HEAT RECOVERY 3-PIPE SYSTEMS)

(OUTDOOR UNIT)

KXZR series (Heat recovery type)

Standard series

•Single use

FDC224KXZRE1,280KXZRE1,335KXZRE1,400KXZRE1,450KXZRE1,475KXZRE1,500KXZRE1,560KXZRE1,
615KXZRE1,670KXZRE1

•Combination use

FDC735KXZRE1,800KXZRE1,850KXZRE1,900KXZRE1,950KXZRE1,1000KXZRE1,1060KXZRE1,1120KXZRE1,
1200KXZRE1,1250KXZRE1,1300KXZRE1,1350KXZRE1,1425KXZRE1,1450KXZRE1,1500KXZRE1,
1560KXZRE1,1620KXZRE1,1680KXZRE1

•High-COP combination use

FDC450KXZRXE1(FDC224KXZRE1+FDC224KXZRE1),
FDC500KXZRXE1(FDC224KXZRE1+FDC280KXZRE1),
FDC560KXZRXE1(FDC280,KXZRE1+FDC280KXZRE1),
FDC615KXZRXE1(FDC280KXZRE1+FDC335KXZRE1),
FDC670KXZRXE1(FDC335KXZRE1+FDC335KXZRE1),
FDC735KXZRXE1(FDC224KXZRE1+FDC224KXZRE1+FDC280KXZRE1),
FDC800KXZRXE1(FDC224KXZRE1+FDC280KXZRE1+FDC280KXZRE1),
FDC850KXZRXE1(FDC280KXZRE1+FDC280KXZRE1+FDC280KXZRE1),
FDC900KXZRXE1(FDC280KXZRE1+FDC280KXZRE1+FDC335KXZRE1),
FDC950KXZRXE1(FDC280KXZRE1+FDC335KXZRE1+FDC335KXZRE1),
FDC1000KXZRXE1(FDC335KXZRE1+FDC335KXZRE1+FDC335KXZRE1)

• Note:

(1) Regarding the Indoor unit series, refer to the No.'15 • KX-T-247

(2) Regarding the Duct Connected-High static Pressure-type Outdoor Air Processing Unit Series (FDU500~1800FKXE6), refer to the DATA BOOK No.'08 • KX-DB-122

PREFACE

Combination table for KX4 series and KX6 series

() Date of launching in the market

Category	Outdoor unit	Indoor unit									
		Connectable remote control	Same series	Same series	Same series	Mixed series	Mixed series	Mixed series	Same or Mixed series	Mixed series	Same series
		3-wire type									
		RC-E1	KXE4	KXE4(A)	KXE4A	KXE4A	KXE4A	KXE4A			
		RC-E1R				KXE4R KXE4BR KXE5R	KXE4R KXE4BR KXE5R	KXE4R KXE4BR KXE5R	KXE4R KXE4BR KXE5R	KXE4R KXE4BR KXE5R	
		2-wire type						KXE6 KXE6A KXE6B KXE6D KXE6F KXZE1	KXE6 KXE6A KXE6B KXE6D KXE6F KXZE1		KXE6 KXE6A KXE6B KXE6D KXE6F KXZE1
Heat pump (2-pipe) systems	FDCA-HKXE4 5HP (2004.4-)		YES [C]	YES [C]	YES [C]	NO	NO	NO	NO	NO	NO
	FDCA-HKXE4 8-48HP (2004.4-)		NO	YES [C]	YES [C]	NO	NO	NO	NO	NO	NO
	FDCA-HKXE4A 5HP (2006.2-)		NO	YES [C]	YES [C]	YES [C] ^{*1}	NO	NO	YES [C] ^{*1}	NO	NO
	FDCA-HKXE4A 8-48HP (2006.2-)										
	FDCA-HKXE4R 8-48HP (2006.5-)		NO	YES [C]	YES [C]	YES [C]	YES [C]	YES [C]	YES [C]	YES [C]	YES [C]
	FDCA-HKXE4BR 8-48HP (2007.4-)										
	FDCA-HKXE4D 8-48HP (2008.7-)										
	FDC-KXE6 4.5,6HP (2008.3-)		NO	NO	NO	NO	NO	NO	NO	NO	YES [A] ^{*6}
	FDC-KXE6 8-12HP (2009.2)		NO	NO	NO	NO	NO	NO	YES [B]	YES [B]	YES [A]
FDC-KXE6 14-48HP (2009.1)		NO	NO	NO	NO	NO	NO	YES [B]	YES [B]	YES [A]	
FDC-KXZE1 10-60HP (2017.4-)		NO	NO	NO	NO	NO	NO	NO	NO	YES [A]	
Heat recovery (3-pipe) systems [Note(3)]	FDCA-HKXRE4 8-48HP (2004.11-)		NO	NO	YES [C]	NO	NO	NO	NO	NO	NO
	FDCA-HKXRE4A 8-48HP (2006.2-)										
	FDCA-HKXRE4R 8-48HP (2006.6-)		NO	NO	YES [C]	YES [C]	YES [C]	YES [C]	YES [C]	YES [C]	YES [C]
	FDCA-HKXRE4BR 8-48HP (2007.4-)										
	FDCA-HKXRE4D 8-48HP (2008.7-)										
	FDC-KXRE6 8-48HP (2009.5-)		NO	NO	NO	NO	NO	NO	YES [B]	YES [B]	YES [A]
FDC-KXZRE1 8-60HP (2017.4-)		NO	NO	NO	NO	NO	NO	NO	NO	YES [A]	

*1 except FDKA71KXE5E

Notes (1) YES: Connectable (See following table in detail), NO: Not connectable

	Outdoor unit	Connected Indoor unit		Dip switch setting of outdoor unit KXE6	Superlink Protocol	Limitation
		Same series	Mixed series			
YES [A] ^{*2}	KXE6&KXZ	KXE6&KXZ		II (New)	New (for KX6)	New (for KX6)
YES [B]		KXE4 series	KXE6 & KXE4 series	I (Previous)	Previous (for KX4)	Previous (for KX4)
YES [C]		KXE4 series	KXE4 series		Previous (for KX4)	Previous (for KX4)

*2 If Outdoor unit system (YES [A]) is connected to other outdoor unit systems (YES [B] and/or YES [C]) in one Superlink network, the dip switch of outdoor unit KXE6 of (YES [A]) should be set from II (New) to I (Previous). In this case the Superlink protocol and limitation of outdoor unit system (YES [A]) are switched to Previous (for KX4).

(2) Combination with new central control, PC windows central control and BMS interface unit

		Central control, PC windows central control and BMS interface unit					
		SC-SL1N-E	SC-SL2N-E	SC-SL4N-AE/BE	SC-WGWN-A/B	SC-LGWN-A	SC-BGWN-A/B
YES [A]	Connectable I/U	16	64	128 (128x1)	128 (64x2) ^{*3}	96 (48x2)	128 (64x2) ^{*3}
	Superlink protocol	New	New	New	New	New	New
YES[B] & YES[C]	Connectable network	1	1	1	2	2	2
	Connectable I/U	16	48	144 (48x3)	96 ^{*4} (48x2) ⁴	96 ^{*4} (48x2) ⁴	96 ^{*4} (48x2) ⁴
	Superlink ^{*5} protocol	Previous	Previous	Previous	Previous	Previous	Previous
	Connectable network	1	1	3	2	2	2

*3 Maximum number of AC cell is limited up to 96.

In case the number of connected indoor units are more than 96, some AC cells should hold 2 or more indoor units.

*4 In case of other central control like SC-SLxN-E is connected in the same network, the connectable indoor unit is limited up to 64 (32x2).

*5 In case of previous Superlink protocol, the Superlink mode of new central control should be set "Previous".

*6 In case of YES[A], previous central control is available to use. But the limitation of connectable indoor unit and so on is complied with the rule of previous Superlink.

(3) The compatibility of PFD (refrigerant flow branching control) is mentioned in following table.

Connectable PFD control		Indoor unit	
		KXE4 & KXE5 series	KXE6 & KXZE1 series
Outdoor unit	KXRE4 series	PFD-E PFD-ER	PFD-E PFD***3-E PFD-ER PFD***4-E(New)
	KXRE6 series	PFD-E PFD-ER	PFD***3-E PFD***4-E(New)
	KXZRE1 series		PFD***3-E PFD***4-E(New)

Note:
All indoor unit downstream PFD box must be same series, KXZR, KX6 series or KX4/5 series

(4) Compatibility of the PFD control extension cables is as per the following table.

		PFD-control series	
		PFD *** 3-E	PFD *** 4-E
PFD-15WR-E	Yes	No	
PFD4-15WR-E	No	Yes	

CONTENTS

1. GENERAL INFORMATION	1
1.1 Specific features.....	1
1.2 Connectable indoor capacity.....	5
1.3 How to read the model name	6
1.4 Table of models	6
1.5 Outdoor units combination table	7
2. OUTDOOR UNIT	8
2.1 Specifications	8
2.2 Exterior dimensions.....	13
2.3 Electrical wiring	15
2.4 Noise level.....	18
3. RANGE OF USAGE & LIMITATIONS	19
4. PIPING SYSTEM	28
5. SELECTION CHART.....	31
6. WARNINGS ON REFRIGERANT LEAKAGE	58
7. TECHNICAL INFORMATION	59
7.1 Outdoor unit	59
7.2 Indoor unit	79

1. GENERAL INFORMATION

1.1 Specific features

(1) High efficiency & comfort

(a) Multiport compressor that achieves high efficiency

The new multiport discharge area in the compressor has optimized pressure control with better balancing. The performance improvement at medium Hz has resulted in higher annual efficiencies.

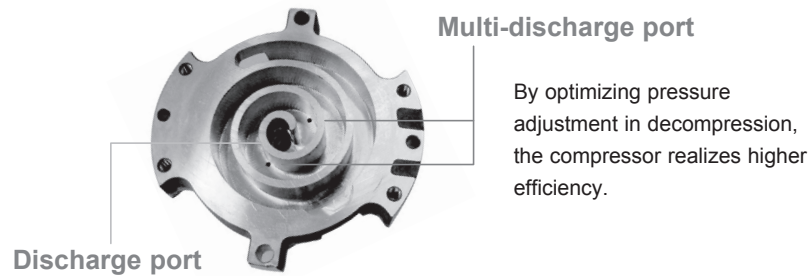

(b) Concentrated winding motor achieves “High output” and “Total efficiency improvement”

The newly designed high performance CPU enables high precision optimization for compressor speed, which leads to concentrated winding motor use. Our product achieves high output and better energy saving effects and in particular improves seasonal efficiency rating.

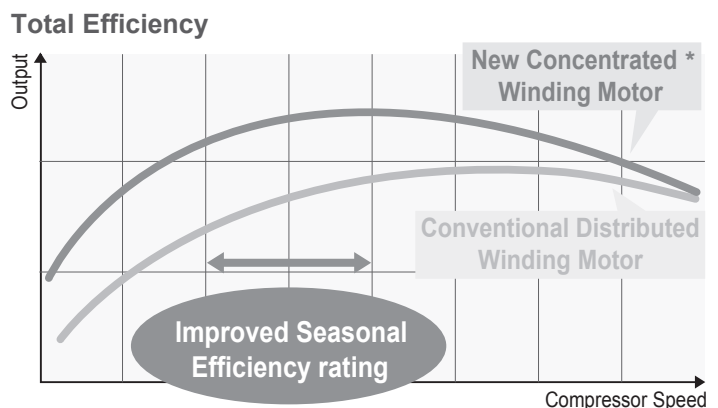

* Applied for KXZE1:10/12/17/18/20HP, KXZXE1:8HP & KXZ Lite:8/10HP

(c) Improved heat-exchanger

With piping layout rearranged from header to heat exchanger, refrigerant distribution flow has improved and maximum energy efficiency has been achieved. Heat exchanger has improved refrigerant distribution and increased effectiveness. Furthermore due to expansion of effective heat transfer area in heat exchanger, energy efficiency has increased.

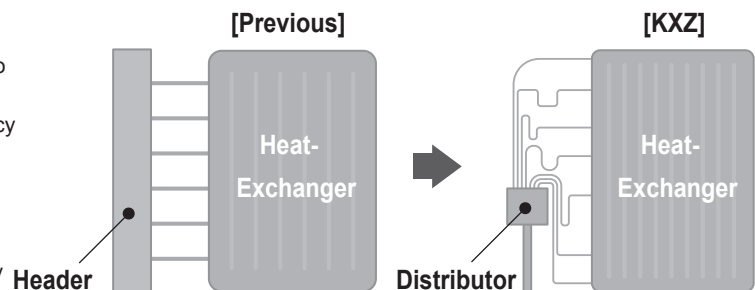

(d) Oil level control capability

Our proprietary technology of adjusting oil level for combination of two or three outdoor units has realized leveled operation rate, keeping performance of the units and ensuring long life of the system.

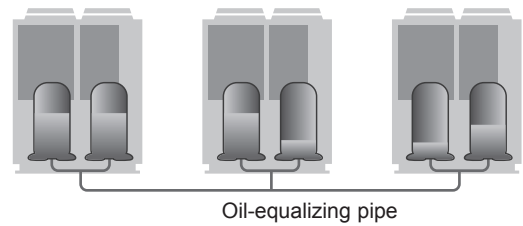

(e) Capacity control (KXZ)

Capacity control can be set by peak cut function with RC-EX3 for better energy saving. Five-step capacity control is available. (100-80-60-40-0%)

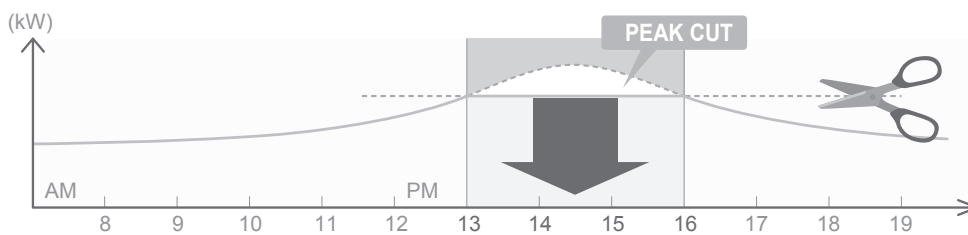

(2) High efficiency in mixed cooling and heating mode

Highly efficient operation mode is automatically determined inside the refrigerant system during simultaneous cooling and heating operation. Heat recovery efficiency is maximized by this control and Max COP 9.0 (*) is achieved during operation with simultaneous cooling and heating.
 * Conditions for simultaneous cooling and heating (Our estimation in 8HP operation and the following conditions: Temperature outside the room DB16°C/WB12°C, temperature in the cooled room DB27°C/19°C, and temperature in the heated room DB20°C/WB14.5°C)

Energy efficiency in heat recovery mode

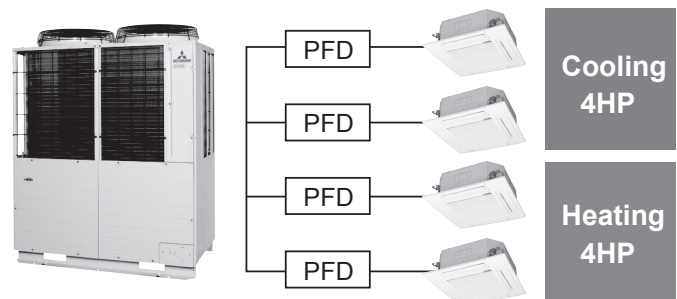
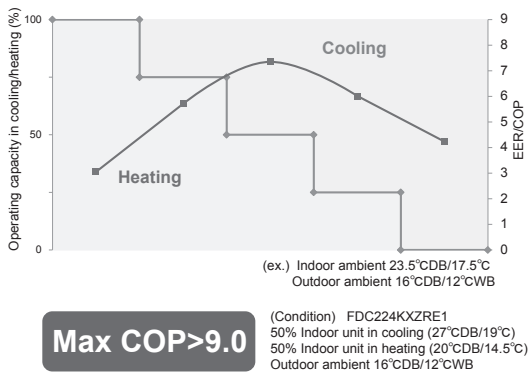

(3) High efficiency

The below graphs highlight the improved efficiencies between the previous models compared to the KXZR standard and Hi-COP models.

(a) Comparison of EER in Cooling Mode

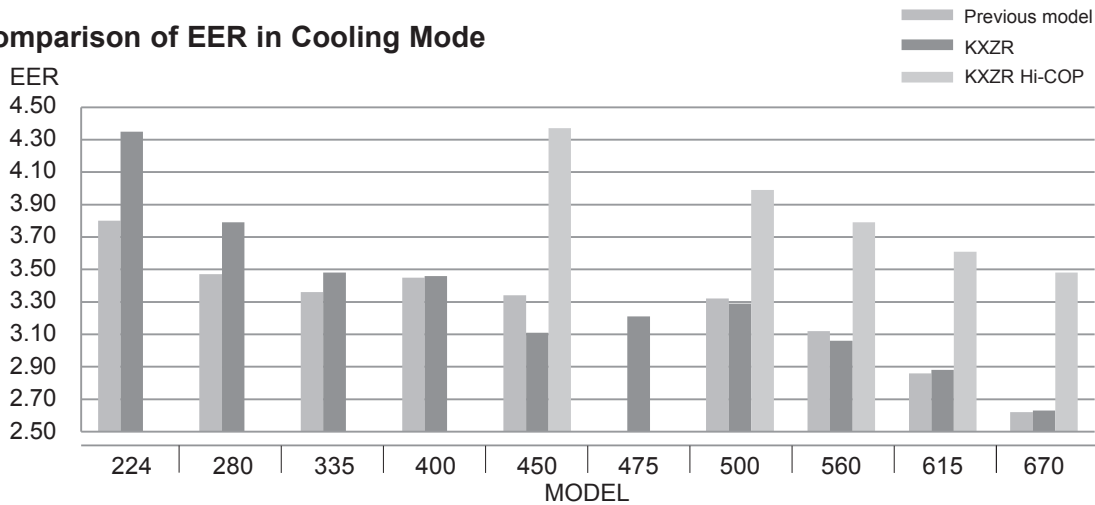

(b) Comparison of COP in Heating Mode

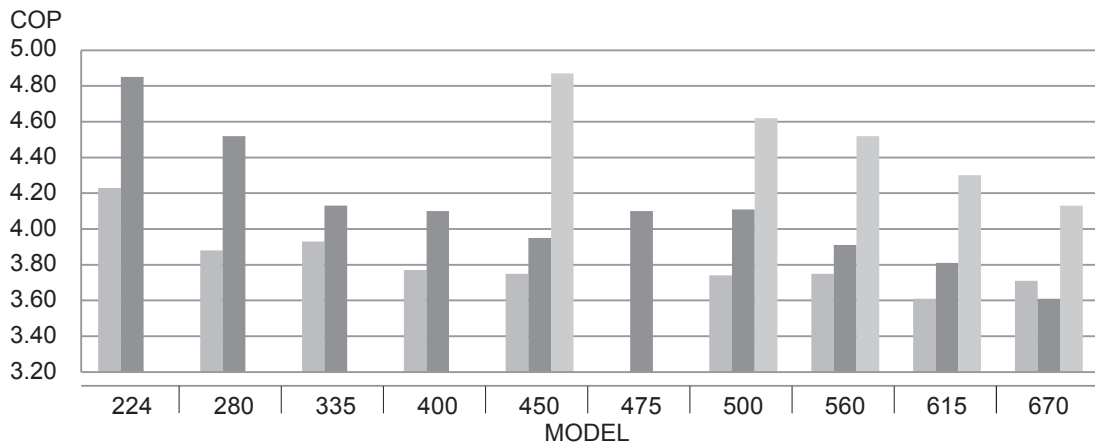

(4) Improved features

(a) New Heating Solution - Continuous Heating Capacity Control (CHCC) -

New defrosting control achieves more capacity than that of previous model in low ambient temperature condition.

Target pressure is controlled automatically before capacity drops, which makes longer period of heating operation and shorter defrosting time.

(*1) Patent is now under being applied. (*2) This control will be activated in specific condition. Please refer to the technical manual in detail.

(b) Improved cooling capacity in low ambient temperature

Small split heat exchanger and pressure control inside make it possible that outdoor unit can operate in cooling operation even with low ambient temperature condition, which achieves more capacity in such low ambient condition at -5°C, compared to previous model.

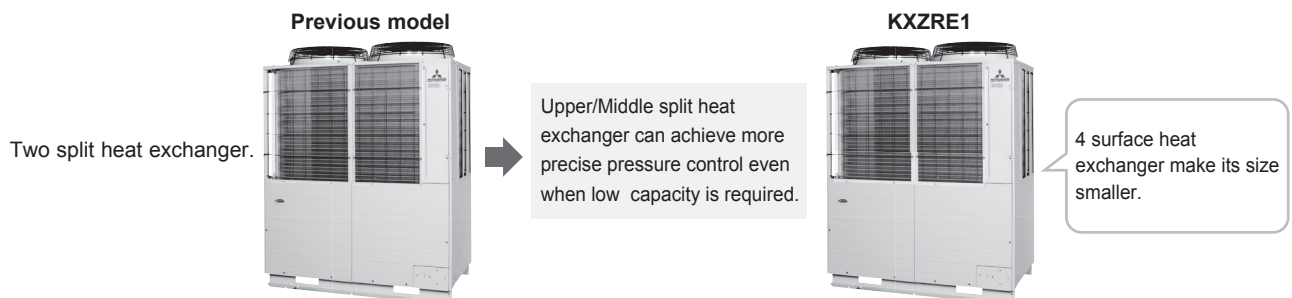

In previous model, when high demand for heating and low cooling demand are required at the same time in low ambient temperature condition, pressure control is adjusted to keep more heating capacity than good enough cooling capacity. New adopted heat exchanger and pressure control in KXZR series, has improved its capacity for both good enough heating and cooling capacity at the same time. (*)

(*) Refrigerant system will priorities required heating mode more than very low cooling demand, in case most of indoor units are operated in heating mode.

* The numeric values are provisional.

Blown air temperature in the cooled room

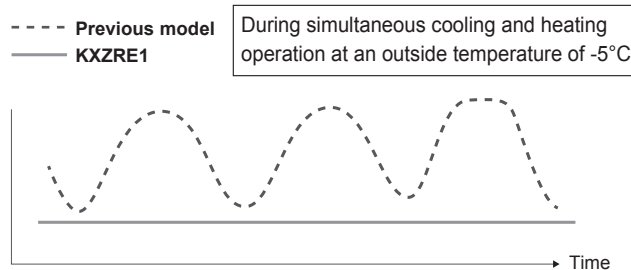

(c) Improvement to the branching control noise level

Sound insulation box design specification, reducing the level of noises from the branching control generated due to the flow of refrigerant or other causes.

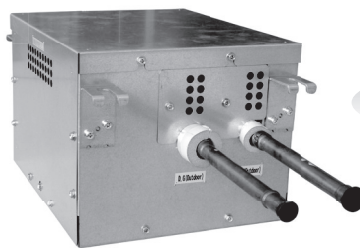

(5) Design flexibility

(a) Indoor unit capacity connection

HP	KXZR	HP	KXZRX
8 - 16	200%	16	200%
17 - 34	160%	18 - 34	160%
36 - 60	130%	36	130%

- In case that capacity connection is more than 130%, additional charge of refrigerant is required on site.
- In case of 8-34HP of the systems, if one or more indoor units of FDK, FDFL, FDFU and/or FDFW series are connected to the system, the total connecting capacity of indoor units should not exceed 130%.

(b) Connectable indoor units

Up to 91 indoor units can be connected to the largest capacity outdoor unit, with a range of 17 types of exposed or concealed indoor unit, in several capacities, a choice of 91 indoor units is available.

(c) Wide range of operation

KXZR series permits an extensible system design considering a heating range operation under a low temperature condition down to -20°C and a cooling range operation up to 46°C (previous model : 43°C)

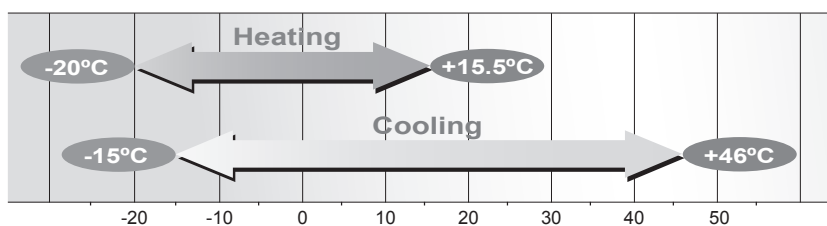

1.2 Connectable indoor capacity

Capacity from 50% to 200% is possible.

Item			Number of connectable				Connectable capacity		
Model				to		units			
FDC	224	KXZRE1	1	to	29	units	112	-	448
FDC	280	KXZRE1	1	to	37	units	140	-	560
FDC	335	KXZRE1	1	to	44	units	168	-	670
FDC	400	KXZRE1	1	to	53	units	200	-	800
FDC	450	KXZRE1	1	to	60	units	225	-	900

Note (1) If one or more indoor units of FDK, FDFL, FDFU and/or FDFW series are connected to the system, the total connecting capacity of indoor units should not exceed 130%.

Capacity from 50% to 160% is possible.

Item			Number of connectable				Connectable capacity		
Model				to		units			
FDC	475	KXZRE1	1	to	50	units	238	-	760
FDC	500	KXZRE1	1	to	53	units	250	-	800
FDC	560	KXZRE1	1	to	59	units	280	-	896
FDC	615	KXZRE1	2	to	65	units	308	-	984
FDC	670	KXZRE1	2	to	71	units	335	-	1072
FDC	735	KXZRE1	2	to	78	units	368	-	1176
FDC	800	KXZRE1	2	to	80	units	400	-	1280
FDC	850	KXZRE1	2	to	80	units	425	-	1360
FDC	900	KXZRE1	2	to	80	units	450	-	1440
FDC	950	KXZRE1	2	to	80	units	475	-	1520

Note (1) If one or more indoor units of FDK, FDFL, FDFU and/or FDFW series are connected to the system, the total connecting capacity of indoor units should not exceed 130%.

Capacity from 50% to 130% is possible.

Item			Number of connectable				Connectable capacity		
Model				to		units			
FDC	1000	KXZRE1	2	to	80	units	500	-	1300
FDC	1060	KXZRE1	2	to	80	units	530	-	1378
FDC	1120	KXZRE1	2	to	80	units	560	-	1456
FDC	1200	KXZRE1	3	to	80	units	600	-	1560
FDC	1250	KXZRE1	3	to	80	units	625	-	1625
FDC	1300	KXZRE1	3	to	80	units	650	-	1690
FDC	1350	KXZRE1	3	to	80	units	675	-	1755
FDC	1425	KXZRE1	3	to	80	units	713	-	1852
FDC	1450	KXZRE1	3	to	80	units	725	-	1885
FDC	1500	KXZRE1	3	to	80	units	750	-	1950
FDC	1560	KXZRE1	3	to	80	units	780	-	2028
FDC	1620	KXZRE1	3	to	80	units	810	-	2106
FDC	1680	KXZRE1	3	to	80	units	840	-	2184

High-COP combination

Capacity from 80% to 200% is possible.

Item			Number of connectable				Connectable capacity		
Model				to		units			
FDC	450	KXZRXE1	2	to	60	units	360	-	900

Note (1) If one or more indoor units of FDK, FDFL, FDFU and/or FDFW series are connected to the system, the total connecting capacity of indoor units should not exceed 130%.

Capacity from 80% to 160% is possible.

Item			Number of connectable				Connectable capacity		
Model				to		units			
FDC	500	KXZRXE1	2	to	53	units	400	-	800
FDC	560	KXZRXE1	2	to	59	units	448	-	896
FDC	615	KXZRXE1	2	to	65	units	492	-	984
FDC	670	KXZRXE1	2	to	71	units	536	-	1072
FDC	735	KXZRXE1	3	to	78	units	588	-	1176
FDC	800	KXZRXE1	3	to	80	units	640	-	1280
FDC	850	KXZRXE1	3	to	80	units	680	-	1360
FDC	900	KXZRXE1	3	to	80	units	720	-	1440
FDC	950	KXZRXE1	3	to	80	units	760	-	1520

Note (1) If one or more indoor units of FDK, FDFL, FDFU and/or FDFW series are connected to the system, the total connecting capacity of indoor units should not exceed 130%.

High-COP combination
Capacity from 80% to 130% is possible.

Item			Number of connectable				Connectable capacity		
Model									
FDC	1000	KXZRXE1	3	to	80	units	800	-	1300

1.3 How to read the model name

(1) Outdoor unit

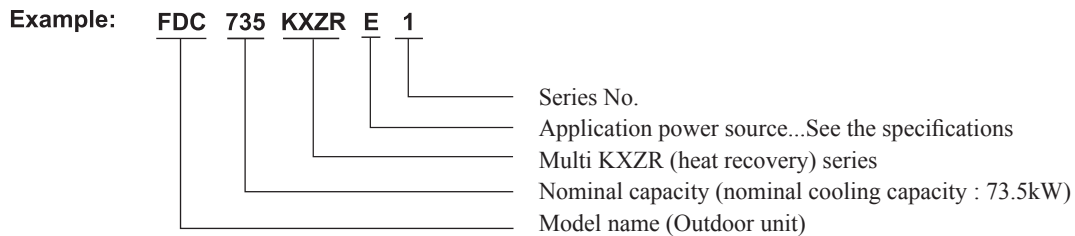

(2) Indoor unit

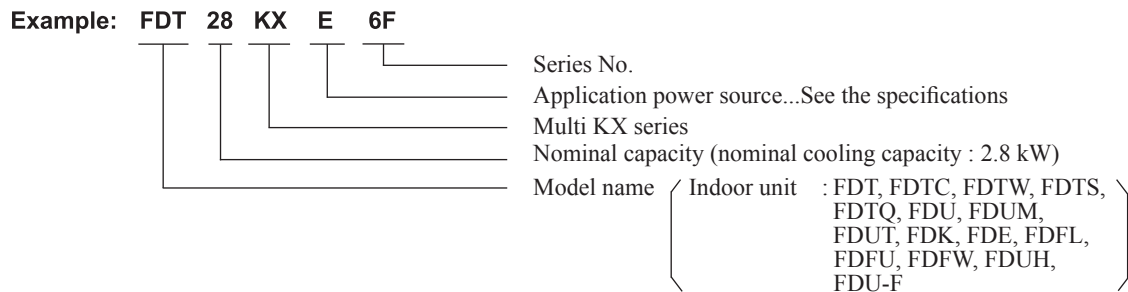

1.4 Table of models

Model	Capacity													
	15	22	28	36	45	56	71	90	112	140	160	224	280	
Ceiling cassette-4 way type (FDT)			○	○	○	○	○	○	○	○	○			
Ceiling cassette-4 way compact type (FDTC)	○	○	○	○	○	○								
Ceiling cassette-2 way type (FDTW)			○		○	○	○	○	○	○				
Ceiling cassette-1 way type (FDTS)					○		○							
Ceiling cassette-1 way compact type (FDTQ)		○	○	○										
Duct connected-High static pressure type (FDU)					○	○	○	○	○	○	○	○	○	○
Duct connected-Low/Middle static pressure type (FDUM)		○	○	○	○	○	○	○	○	○	○			
Duct connected (thin)-Low static pressure type (FDUT)	○	○	○	○	○	○	○							
Wall mounted type (FDK)		○	○	○	○	○	○							
Ceiling suspended type (FDE)				○	○	○	○		○	○				
Floor standing (with casing) type (FDFL)							○							
Floor standing (without casing) type (FDFU)			○		○	○	○							
Floor standing-2 way type (FDFW)			○		○	○								
Duct connected-compact and Flexible type (FDUH)		○	○	○										
Outdoor air processing unit (FDU-F)								○		○		○	○	○
Outdoor units to be combined (FDC)	FDC224KXZRE1-FDC1680KXZRE1													

Note (1) Reference No. of data book : '15·KX-DB-247

1.5 Outdoor units combination table

Model	Item	FDC 335	FDC 400	FDC 450	FDC 475	FDC 500	FDC 560	Connectable capacity		Number of connectable					
		KXZRE1	KXZRE1	KXZRE1	KXZRE1	KXZRE1	KXZRE1								
FDC 735	KXZRE1	1	1					368	—	1176	2	to	78	units	
FDC 800	KXZRE1		2					400	—	1280	2	to	80	units	
FDC 850	KXZRE1		1	1				425	—	1360	2	to	80	units	
FDC 900	KXZRE1			2				450	—	1440	2	to	80	units	
FDC 950	KXZRE1					2		475	—	1520	2	to	80	units	
FDC 1000	KXZRE1						2	500	—	1300	2	to	80	units	
FDC 1060	KXZRE1						1	530	—	1378	2	to	80	units	
FDC 1120	KXZRE1							2	560	—	1456	2	to	80	units
FDC 1200	KXZRE1		3					600	—	1560	3	to	80	units	
FDC 1250	KXZRE1		2	1				625	—	1625	3	to	80	units	
FDC 1300	KXZRE1		1	2				650	—	1690	3	to	80	units	
FDC 1350	KXZRE1			3				675	—	1755	3	to	80	units	
FDC 1425	KXZRE1				3			713	—	1852	3	to	80	units	
FDC 1450	KXZRE1				2	1		725	—	1885	3	to	80	units	
FDC 1500	KXZRE1					3		750	—	1950	3	to	80	units	
FDC 1560	KXZRE1					2	1	780	—	2028	3	to	80	units	
FDC 1620	KXZRE1					1	2	810	—	2106	3	to	80	units	
FDC 1680	KXZRE1						3	840	—	2184	3	to	80	units	

High-COP combination

Model	Item	FDC 224	FDC 280	FDC 335	Connectable capacity		Number of connectable				
		KXZRE1	KXZRE1	KXZRE1							
FDC 450	KXZRE1	2			360	—	900	2	to	60	units
FDC 500	KXZRE1	1	1		400	—	800	2	to	53	units
FDC 560	KXZRE1		2		448	—	896	2	to	59	units
FDC 615	KXZRE1		1	1	492	—	984	2	to	65	units
FDC 670	KXZRE1			2	536	—	1072	2	to	71	units
FDC 735	KXZRE1	2	1		588	—	1176	3	to	78	units
FDC 800	KXZRE1	1	2		640	—	1280	3	to	80	units
FDC 850	KXZRE1		3		680	—	1360	3	to	80	units
FDC 900	KXZRE1		2	1	720	—	1440	3	to	80	units
FDC 950	KXZRE1		1	2	760	—	1520	3	to	80	units
FDC 1000	KXZRE1			3	800	—	1600	3	to	80	units

(a) Outdoor unit side branch pipe set (Option)

Outdoor unit	Branch pipe set
For two units	DOS-2A-3-R
For three units	DOS-3A-3-R

Note (1) Be sure to use this when combining units.

(b) Branch pipe set (Option)

In the upstream of a branching control

Total capacity downstream	Branching pipe set
Less than 180	DIS-22-1-R
180 or more but less than 371	DIS-180-1-R
371 or more but less than 540	DIS-371-2-R
540 or more	DIS-540-2-R

In the downstream of a branching control

Total capacity downstream	Branch pipe set
Less than 180	DIS-22-1
180 or more but less than 371	DIS-180-1
371 or more but less than 540	DIS-371-1
540 or more	DIS-540-1

(c) Branching control model (Option)

Total capacity downstream	Branching control model	Number of connectable units
Less than 112	PFD1124-E	1 - 5
112 or more but less than 180	PFD1804-E	1 - 8
180 or more but less than 280	PFD2804-E	1 - 10

• Restriction on the number of branching controls to be connected to the outdoor unit

Outdoor unit	Minimum number of connectable units	Outdoor unit	Minimum number of connectable units
-280(10HP)	2 units	-1130(40HP)	8 units
-560(20HP)	4 units	-1680(60HP)	10 units
-850(30HP)	6 units	—	—

(d) Integrated branching control (Option)

Model	Total of four branches		Per branch	
	Capacity restrictions	Maximum number of connectable units	Capacity restrictions	Maximum number of connectable units
PFD1124X4-E	Less than 371	16	Less than 112	5

2. OUTDOOR UNIT

2.1 Specifications

• Single use (Used also for combination)

Model	FDC224KXZRE1	FDC280KXZRE1	FDC355KXZRE1	FDC400KXZRE1	FDC450KXZRE1	FDC478KXZRE1	FDC500KXZRE1	FDC560KXZRE1	FDC615KXZRE1	FDC670KXZRE1
Nominal cooling capacity*1	22.4	28.0	33.5	40.0	45.0	47.5	50.0	56.0	61.5	67.0
Nominal heating capacity*2	22.4	28.0	33.5	40.0	45.0	47.5	50.0	56.0	61.5	63.0
Maximum heating capacity	25.0	31.5	37.5	45.0	50.0	53.0	56.0	63.0	63.0	63.0
Power source	3 Phase 380/415V 50Hz / 380V 60Hz									
Power consumption	5.15	7.38	9.64	11.55	14.45	14.82	15.19	18.31	21.35	25.51
Running current	9.0/8.3	12.2/11.2	15.8/14.5	18.5/17.1	23.2/21.2	24.0/22.0	24.6/22.5	29.6/27.1	34.6/31.6	41.3/37.8
Power factor	87/87	92/92	93/93	95/94	93/93	94/94	94/94	94/94	94/94	94/94
EER	4.35	3.47	3.79	3.46	3.11	3.20	3.29	3.05	2.88	2.62
COP	4.84	4.52	4.12	4.09	3.95	4.10	4.10	3.90	3.80	3.60
Sound pressure level (Cooling/Heating)	55/57	55/57	61/58	60/62	61/62	61/62	61/62	64/65	65/66	65/66
Sound power level (Cooling/Heating)	73/75	74/76	81/77	81/83	82/83	81/82	81/82	84/85	84/85	84/85
Starting current	5									
Exterior dimensions	A									
Height x Width x Depth	1690x1350x720									
Exterior appearance (Munsell color)	Stucco White (4.2/7.5/1.1) near equivalent									
Net weight	289									
Refrigerant equipment compressor type & Q'ty	G1C5150NC47LF X 1									
Motor	3.41 X 1	4.80 X 1	6.54 X 1	7.92 X 1	9.73 X 1	4.53 X 2	4.84 X 2	5.79 X 2	7.05 X 2	9.87 X 2
Starting method	Direct line starting									
Compressor heater	40 X 1									
Refrigerant equipment	M fin & inner grooved tubing									
Heat exchanger	Electronic expansion valve									
Refrigerant control	R410A									
Refrigerant type	11.5									
Refrigerant amount	3.3 (M-MA32R)									
Refrigerant oil	2.35 (M-MA32R)									
Deerost control	Microcomputer controlled De-Icer									
Air handling equipment fan type & Q'ty	Propeller fan x 2									
Motor	366x2									
Starting method	Direct start									
Air flow (Standard)	220/200									
Available external static pressure	280/260									
Shock & vibration absorber	Max.50									
Safety equipment	Compressor overheat protection / overcurrent protection / power transistor overheating protection / abnormal high pressure protection									
Insulation data	Liquid Line: $\phi 9.52 (3/8")$									
Refrigerant piping size	Suction gas line: $\phi 19.05 (3/4")$									
Connecting method	Discharge gas line: $\phi 15.88 (5/8")$									
MAX. Pressure	MPa									
Drain	Hole for drain ($\phi 20 \times 10$ pcs., $\phi 45 \times 3$ pcs)									
Insulation for piping	IP24									
Accessories	Necessary (both Liquid & Gas line)									
Exterior dimensions	PCB004Z087									
Electrical wiring	PCB004Z089									

Notes (1) The data are measured at the following conditions.

Item	Indoor air temperature		Outdoor air temperature		Standards
	DB	WB	DB	WB	
Operation	27 °C	19 °C	35 °C	24 °C	ISO-11
Cooling	20 °C	-	7 °C	6 °C	
Heating	20 °C	-	7 °C	6 °C	

(2) This air-conditioner is manufactured and tested in conformity with the ISO.

(3) Sound level indicates the value in an anechoic chamber.

During operation these value are somewhat higher due to ambient conditions.

(4) Refrigerant piping size applicable to European installations are shown in parentheses.

(5) This air-conditioner is adapted RoHS directive.

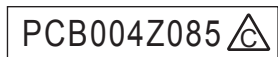

• Combination use

Model	FDC735KXZRE1	FDC800KXZRE1	FDC850KXZRE1	FDC900KXZRE1
Combination unit	FDC335KXZRE1 FDC400KXZRE1	FDC400KXZRE1 FDC450KXZRE1	FDC400KXZRE1 FDC450KXZRE1	FDC450KXZRE1 FDC450KXZRE1
Power source	3 Phase 380-415V 50Hz/380V 60Hz			
Nominal cooling capacity*1	73.5	80.0	85.0	90.0
Nominal heating capacity*2	73.5	80.0	85.0	90.0
Power consumption	Cooling	21.2	23.1	28.9
	Heating	17.9	19.5	22.8
Running current	Cooling	34.30/31.60	37.00/34.20	46.40/42.40
	Heating	29.30/27.00	32.00/29.60	37.20/34.20
Power factor	Cooling	94/94	95/94	95/95
	Heating	93/93	93/92	93/93
Net weight	646	714	714	714
Refrigerant piping size	Liquid line	φ15.88 (5/8")		
	Suction gas line	φ31.75 (1.1/4") (φ34.92 (1.3/8"))		
	Discharge gas line	φ25.4 (1") (φ28.58 (1.1/8"))		
	Oil equalization	φ9.52 (3/8")		

Model	FDC950KXZRE1	FDC1000KXZRE1	FDC1060KXZRE1	FDC1200KXZRE1
Combination unit	FDC475KXZRE1 FDC475KXZRE1	FDC500KXZRE1 FDC500KXZRE1	FDC500KXZRE1 FDC560KXZRE1	FDC560KXZRE1 FDC560KXZRE1
Power source	3 Phase 380-415V 50Hz/380V 60Hz			
Nominal cooling capacity*1	95.0	100.0	106.0	112.0
Nominal heating capacity*2	95.0	100.0	106.0	112.0
Power consumption	Cooling	29.6	30.4	36.6
	Heating	23.2	24.3	28.7
Running current	Cooling	48.00/44.00	49.20/45.00	59.20/54.20
	Heating	37.60/34.40	39.40/36.20	46.40/42.60
Power factor	Cooling	94/94	94/94	94/94
	Heating	94/94	94/94	94/94
Net weight	820	820	820	820
Refrigerant piping size	Liquid line	φ15.88 (5/8")		
	Suction gas line	φ31.75 (1.1/4") (φ34.92 (1.3/8"))		
	Discharge gas line	φ28.58 (1.1/8")		
	Oil equalization	φ9.52 (3/8")		

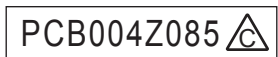

• Combination use

Model	FDC1200KXZRE1	FDC1250KXZRE1	FDC1300KXZRE1	FDC1350KXZRE1	FDC1425KXZRE1	
Combination unit	FDC400KXZRE1	FDC400KXZRE1	FDC400KXZRE1	FDC450KXZRE1	FDC475KXZRE1	
	FDC400KXZRE1	FDC400KXZRE1	FDC400KXZRE1	FDC450KXZRE1	FDC475KXZRE1	
	FDC400KXZRE1	FDC450KXZRE1	FDC450KXZRE1	FDC450KXZRE1	FDC475KXZRE1	
	FDC400KXZRE1	FDC450KXZRE1	FDC450KXZRE1	FDC450KXZRE1	FDC475KXZRE1	
Power source	3 Phase 380-415V 50Hz/380V 60Hz					
Nominal cooling capacity*1	120.0	125.0	130.0	135.0	142.5	
Nominal heating capacity*2	120.0	125.0	130.0	135.0	142.5	
Power consumption	Cooling	34.65	37.55	40.45	43.35	44.46
	Heating	29.28	30.90	32.52	34.14	34.74
Running current	Cooling	55.5/51.3	60.2/55.4	64.9/59.5	69.6/63.6	72.0/66.0
	Heating	48.0/44.4	50.6/46.7	53.2/49.0	55.8/51.3	56.4/51.6
Power factor	Cooling	95/94	95/94	95/95	95/95	94/94
	Heating	93/92	93/92	93/93	93/93	94/94
Net weight	1071	1071	1071	1071	1230	
Refrigerant piping size	Liquid line	ø19.05 (3/4")				
	Suction gas line	ø38.1 (1.1/2") (ø34.92 (1.1/8"))				
	Discharge gas line	ø31.75 (1.1/4") (ø28.58 (1.1/8"))				
	Oil equalization	ø9.52 (3/8")				

Model	FDC1450KXZRE1	FDC1500KXZRE1	FDC1560KXZRE1	FDC1620KXZRE1	FDC1680KXZRE1	
Combination unit	FDC475KXZRE1	FDC500KXZRE1	FDC500KXZRE1	FDC500KXZRE1	FDC560KXZRE1	
	FDC475KXZRE1	FDC500KXZRE1	FDC500KXZRE1	FDC560KXZRE1	FDC560KXZRE1	
	FDC500KXZRE1	FDC500KXZRE1	FDC560KXZRE1	FDC560KXZRE1	FDC560KXZRE1	
	FDC500KXZRE1	FDC500KXZRE1	FDC560KXZRE1	FDC560KXZRE1	FDC560KXZRE1	
Power source	3 Phase 380-415V 50Hz/380V 60Hz					
Nominal cooling capacity*1	145.0	150.0	156.0	162.0	168.0	
Nominal heating capacity*2	145.0	150.0	156.0	162.0	168.0	
Power consumption	Cooling	44.83	45.57	48.69	51.81	54.93
	Heating	35.33	36.51	38.67	40.83	42.99
Running current	Cooling	72.6/66.5	73.8/67.5	78.8/72.1	83.8/76.7	88.8/81.3
	Heating	57.3/52.5	59.1/54.3	62.6/57.5	66.1/60.7	69.6/63.9
Power factor	Cooling	94/94	94/94	94/94	94/94	94/94
	Heating	94/94	94/94	94/94	94/94	94/94
Net weight	1230	1230	1230	1230	1230	
Refrigerant piping size	Liquid line	ø19.05 (3/4")				
	Suction gas line	ø38.1 (1.1/2") (ø34.92 (1.1/8"))				
	Discharge gas line	ø31.75 (1.1/4") (ø28.58 (1.1/8"))				
	Oil equalization	ø9.52 (3/8")				

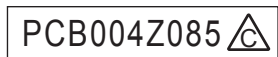

• High-COP Combination use

Model	FDC450KXZRXE1	FDC500KXZRXE1	FDC560KXZRXE1	FDC615KXZRXE1	FDC670KXZRXE1
Combination unit	FDC224KXZRE1	FDC224KXZRE1	FDC280KXZRE1	FDC280KXZRE1	FDC335KXZRE1
Power source	FDC224KXZRE1	FDC280KXZRE1	FDC280KXZRE1	FDC335KXZRE1	FDC335KXZRE1
Nominal cooling capacity*1	45.0	50.0	56.0	61.5	67.0
Nominal heating capacity*2	45.0	50.0	56.0	61.5	67.0
Power consumption	10.29	12.53	14.76	17.02	19.28
Running current	18.0/16.6	21.2/19.5	24.4/22.4	28.0/25.7	31.6/29.0
Power factor	87/87	90/90	92/92	93/93	93/93
Net weight	88/88	90/90	92/92	93/93	93/93
Liquid line	578	578	578	578	578
Suction gas line	φ12.7 (1/2")				
Discharge gas line	φ28.58 (1.1/8")				
Oil equalization	φ9.52 (3/8")				
Refrigerant piping size	φ25.4 (1") (φ22.22 (7/8"))				
Model	FDC735KXZRXE1	FDC800KXZRXE1	FDC850KXZRXE1	FDC900KXZRXE1	FDC1000KXZRXE1
Combination unit	FDC224KXZRE1	FDC224KXZRE1	FDC280KXZRE1	FDC280KXZRE1	FDC335KXZRE1
Power source	FDC280KXZRE1	FDC280KXZRE1	FDC280KXZRE1	FDC335KXZRE1	FDC335KXZRE1
Nominal cooling capacity*1	73.5	80.0	85.0	90.0	100.0
Nominal heating capacity*2	73.5	80.0	85.0	90.0	100.0
Power consumption	17.67	19.91	22.14	24.40	28.92
Running current	30.2/27.8	33.4/30.7	36.6/33.6	40.2/36.9	47.4/43.5
Power factor	89/89	90/90	92/92	92/92	93/93
Net weight	89/89	91/91	92/92	92/92	93/93
Liquid line	867	867	867	867	867
Suction gas line	φ15.88 (5/8")				
Discharge gas line	φ31.75 (1.1/4") (φ34.92 (1.3/8"))				
Oil equalization	φ9.52 (3/8")				
Refrigerant piping size	φ25.4 (1") (φ28.58 (1.1/8"))				
Oil equalization	φ9.52 (3/8")				

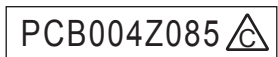

•Weights of packing parts

Unit : kg

Model	Material	Gross weight	Packing parts weight (Total)	Paper	Foam Polystyrene	Plastic	Metal		Wood	Glass	Other
							Aluminium	Steel			
Outdoor unit	FDC224KXZRE1	312.00	23.00	0.04	—	0.10	—	0.81	22.06	—	—
	FDC280KXZRE1	312.00	23.00	0.04	—	0.10	—	0.81	22.06	—	—
	FDC335KXZRE1	312.00	23.00	0.04	—	0.10	—	0.81	22.06	—	—
	FDC400KXZRE1	380.00	23.00	0.04	—	0.10	—	0.81	22.06	—	—
	FDC450KXZRE1	380.00	23.00	0.04	—	0.10	—	0.81	22.06	—	—
	FDC475KXZRE1	433.00	23.00	0.04	—	0.10	—	0.81	22.06	—	—
	FDC500KXZRE1	433.00	23.00	0.04	—	0.10	—	0.81	22.06	—	—
	FDC560KXZRE1	433.00	23.00	0.04	—	0.10	—	0.81	22.06	—	—
	FDC615KXZRE1	433.00	23.00	0.04	—	0.10	—	0.81	22.06	—	—
	FDC670KXZRE1	433.00	23.00	0.04	—	0.10	—	0.81	22.06	—	—
PFD branching control	PFD1124-E	14.10	4.30	4.02	—	0.28	—	—	—	—	—
	PFD1804-E	14.20	3.90	3.62	—	0.28	—	—	—	—	—
	PFD2804-E	16.40	4.50	4.22	—	0.28	—	—	—	—	—
	PFD1124X4-E	56.80	15.90	15.04	—	0.86	—	—	—	—	—

2.2 Exterior dimensions

Models FDC224KXZRE1, 280KXZRE1, 335KXZRE1

MARK	Content	224	280	335
A	Refrigerant suction gas piping connection pipe	∅19.05 (BRAZING)	∅22.22 (BRAZING)	∅25.4 (BRAZING)
B	Refrigerant liquid piping connection pipe	∅9.52 (FLARE)		∅12.7 (FLARE)
C	Refrigerant discharge gas piping connection pipe	∅15.88 (BRAZING)	∅19.05 (BRAZING)	
D	Power source entry hole	∅50 (Right Left-Front)	Long hole 40X80 (Bottom)	
F	Anchor bolt hole	M10, 4pcs.		
G	Drain waste water hose hole	∅45, 3pcs.		
H	Drain hole	∅20, 10pcs.		
K	Refrigerant oil equalization piping connection pipe	∅3.52 (Flare)		
L	Carrying in or hole for hanging	230X60		
N	Refrigerant piping exit hole	∅88 (or ∅100)		

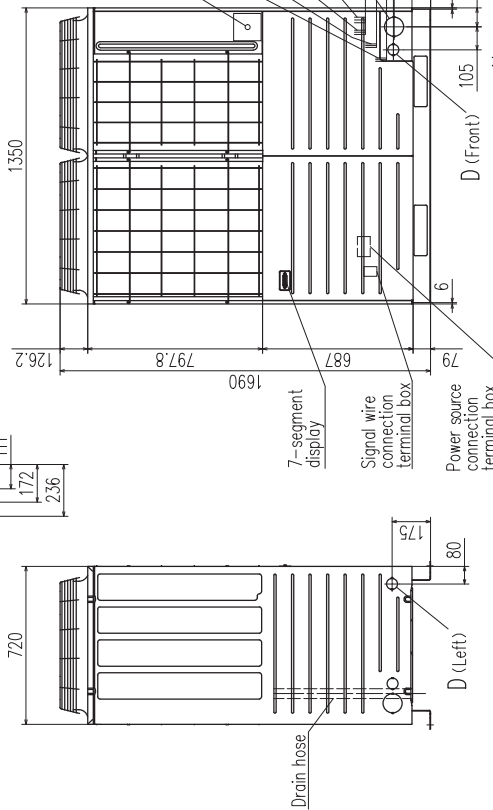
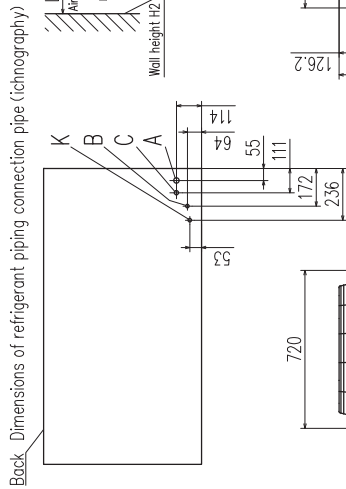
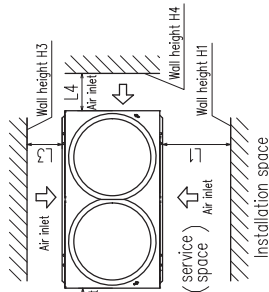

() : in case it is the promised installation location that the outdoor unit is used on conditions with the ambient temperature of 43°C or more.

Unit: mm

Installation position	1	2
L1	500	Open
L2	10 (30)	10 (30)
L3	100	100
L4	10 (30)	Open
H1	1500	Open
H2	No limit	No limit
H3	1000	No limit
H4	No limit	Open

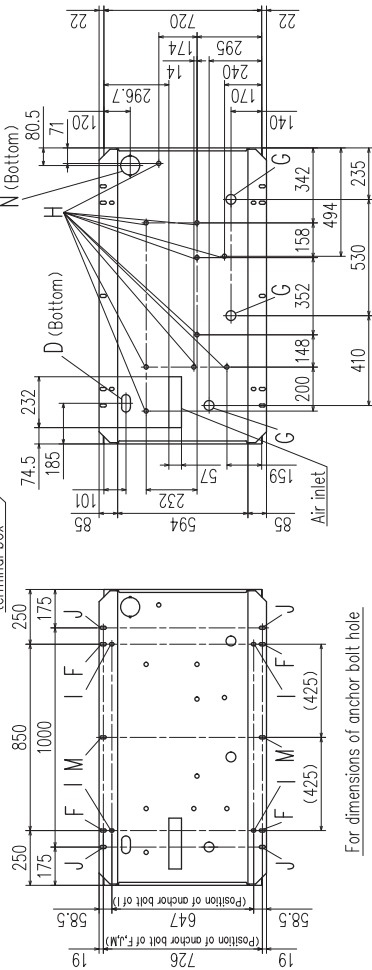

PCB004Z087

**Models FDC400KXZRE1, 450KXZRE1, 475KXZRE1, 500KXZRE1, 560KXZRE1
FDC615KXZRE1, 670KXZRE1**

MARK	Content	400	450,475,500,560	615,670
A	Refrigerant suction gas piping connection pipe	ø25.4 (BRAZING)	ø28.58 (BRAZING)	
B	Refrigerant liquid piping connection pipe		ø12.7 (Flare)	
C	Refrigerant discharge gas piping connection pipe	ø22.22 (BRAZING)	ø25.4 (BRAZING)	
D	Power source entry hole	ø50 (Right-Left-Front), Long hole 40X80 (Bottom)	M10, 4pcs.	
F	Anchor bolt hole		ø45, 3pcs.	
G	Drain waste water hose hole		ø20, 10pcs.	
H	Drain hole		ø9.52 (Flare)	
K	Refrigerant oil equalization piping connection pipe		230X60	
L	Carrying in or hole for hanging		ø88 (or ø100)	
N	Refrigerant piping exit hole			

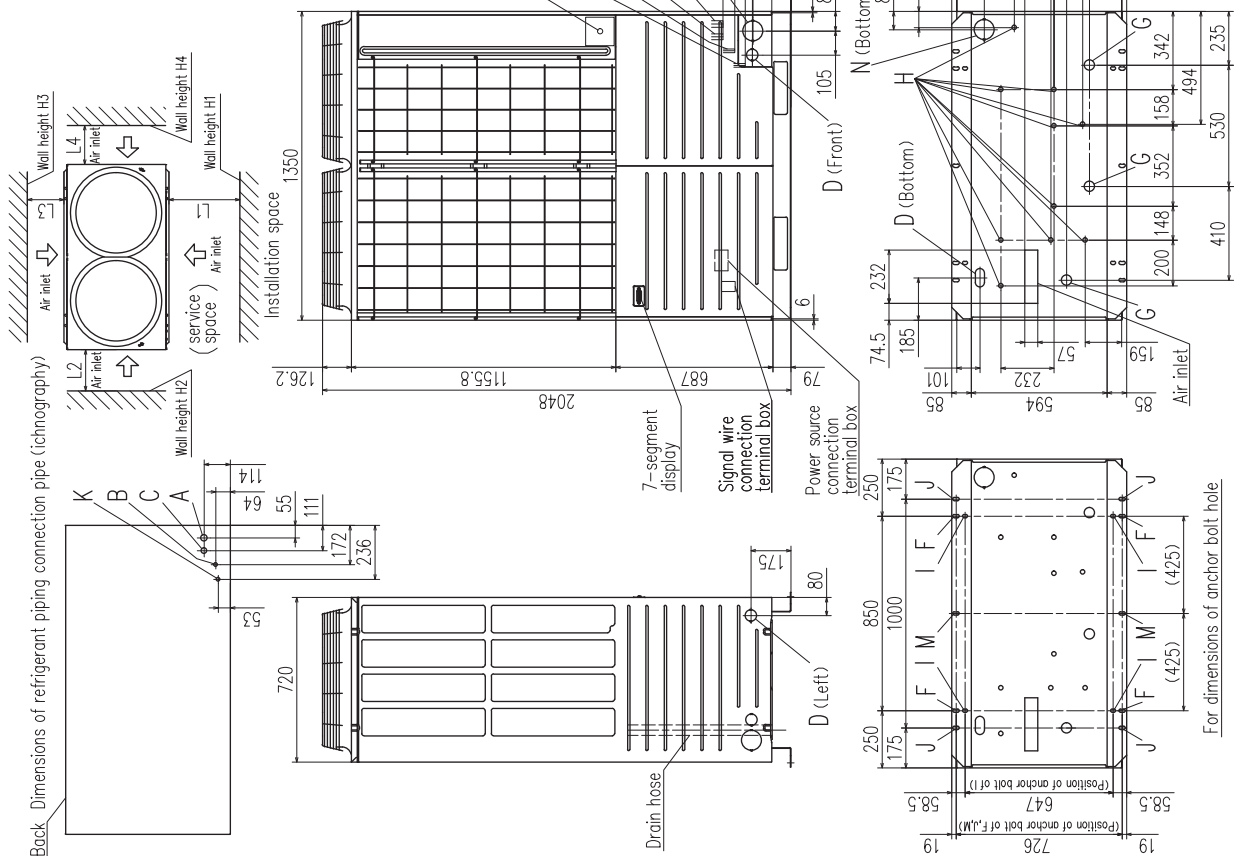

Installation dimensions	1	2
L1	500	Open
L2	10 (30)	10 (30)
L3	100	100
L4	10 (30)	Open
H1	1500	Open
H2	No limit	No limit
H3	1000	No limit
H4	No limit	Open

() : in case it is the promised installation location that the outdoor unit is used on conditions with the ambient temperature of 43°C or more.

Unit:mm

PCB004Z088

2.3 Electrical wiring

Models FDC224KXZRE1, 280KXZRE1, 335KXZRE1

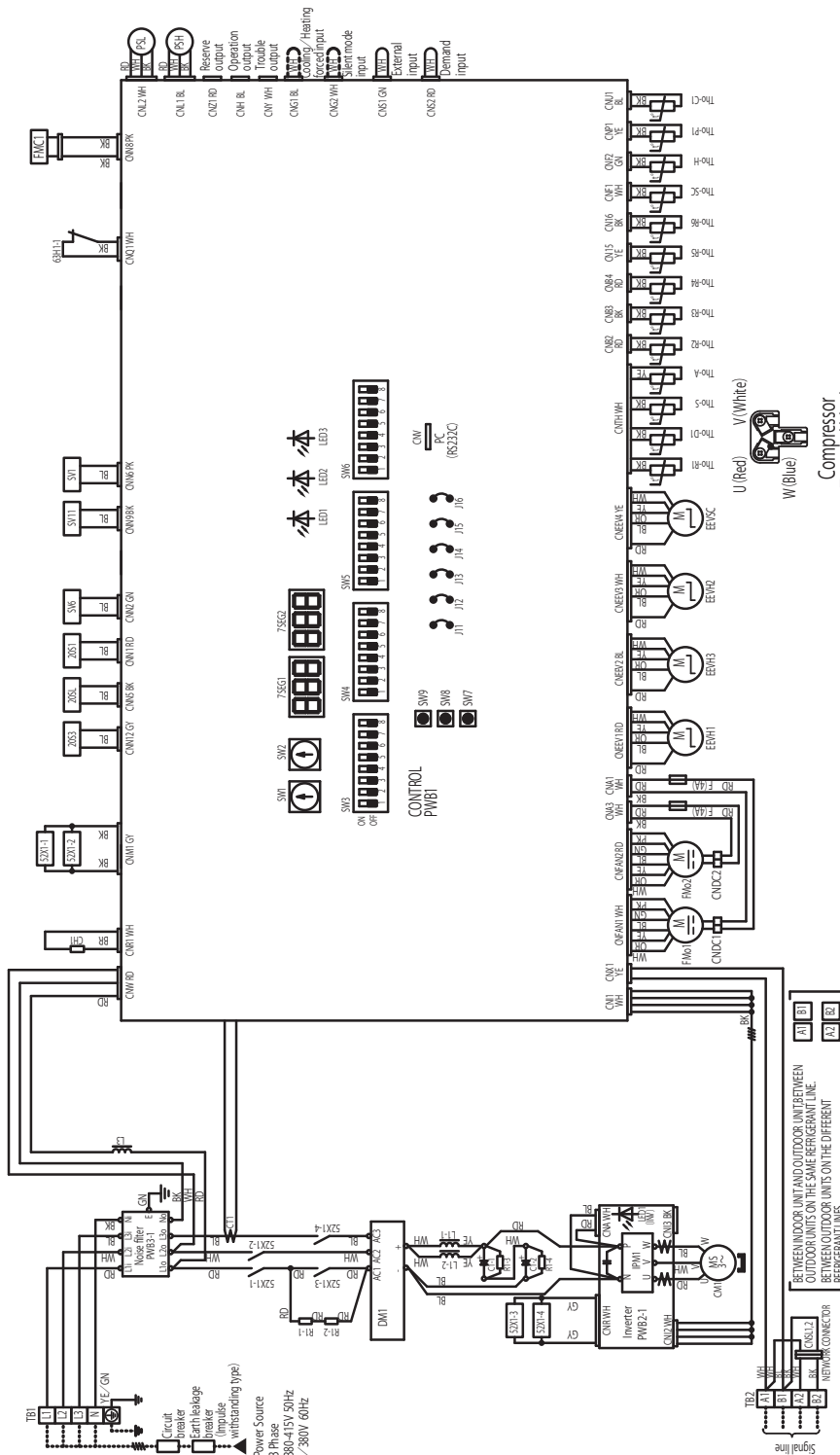

Color mark

Mark	Color
BK	Black
BL	Blue
BR	Brown
GN	Green
GY	Grey
OR	Orange
RD	Red
WH	White
YE	Yellow
PK	Pink
YE/GN	Yellow / Green

Compressor Terminal block

Mark	Parts name
Tho-C1	Under-dome thermistor
Tho-D1	Discharge pipe thermistor
Tho-H	Sub-cooling coil thermistor 2
Tho-P1	Power transistor thermistor
Tho-F1	Heat exchanger thermistor (exhaust)
Tho-R1	Heat exchanger thermistor (exhaust)
Tho-B1	Heat exchanger thermistor (inlet)
Tho-W1	Heat exchanger thermistor (inlet)
Tho-Y1	Heat exchanger thermistor (inlet)
Tho-P2	Sub-cooling coil thermistor 1
Tho-S1	4-way valve
Tho-S2	4-way valve
Tho-S3	4-way valve
Tho-S4	4-way valve
Tho-S5	4-way valve
Tho-S6	4-way valve
Tho-S7	4-way valve
Tho-S8	4-way valve
Tho-S9	4-way valve
Tho-S10	4-way valve
Tho-S11	4-way valve
Tho-S12	4-way valve
Tho-S13	4-way valve
Tho-S14	4-way valve
Tho-S15	4-way valve
Tho-S16	4-way valve
Tho-S17	4-way valve
Tho-S18	4-way valve
Tho-S19	4-way valve
Tho-S20	4-way valve
Tho-S21	4-way valve
Tho-S22	4-way valve
Tho-S23	4-way valve
Tho-S24	4-way valve
Tho-S25	4-way valve
Tho-S26	4-way valve
Tho-S27	4-way valve
Tho-S28	4-way valve
Tho-S29	4-way valve
Tho-S30	4-way valve
Tho-S31	4-way valve
Tho-S32	4-way valve
Tho-S33	4-way valve
Tho-S34	4-way valve
Tho-S35	4-way valve
Tho-S36	4-way valve
Tho-S37	4-way valve
Tho-S38	4-way valve
Tho-S39	4-way valve
Tho-S40	4-way valve
Tho-S41	4-way valve
Tho-S42	4-way valve
Tho-S43	4-way valve
Tho-S44	4-way valve
Tho-S45	4-way valve
Tho-S46	4-way valve
Tho-S47	4-way valve
Tho-S48	4-way valve
Tho-S49	4-way valve
Tho-S50	4-way valve
Tho-S51	4-way valve
Tho-S52	4-way valve
Tho-S53	4-way valve
Tho-S54	4-way valve
Tho-S55	4-way valve
Tho-S56	4-way valve
Tho-S57	4-way valve
Tho-S58	4-way valve
Tho-S59	4-way valve
Tho-S60	4-way valve
Tho-S61	4-way valve
Tho-S62	4-way valve
Tho-S63	4-way valve
Tho-S64	4-way valve
Tho-S65	4-way valve
Tho-S66	4-way valve
Tho-S67	4-way valve
Tho-S68	4-way valve
Tho-S69	4-way valve
Tho-S70	4-way valve
Tho-S71	4-way valve
Tho-S72	4-way valve
Tho-S73	4-way valve
Tho-S74	4-way valve
Tho-S75	4-way valve
Tho-S76	4-way valve
Tho-S77	4-way valve
Tho-S78	4-way valve
Tho-S79	4-way valve
Tho-S80	4-way valve
Tho-S81	4-way valve
Tho-S82	4-way valve
Tho-S83	4-way valve
Tho-S84	4-way valve
Tho-S85	4-way valve
Tho-S86	4-way valve
Tho-S87	4-way valve
Tho-S88	4-way valve
Tho-S89	4-way valve
Tho-S90	4-way valve
Tho-S91	4-way valve
Tho-S92	4-way valve
Tho-S93	4-way valve
Tho-S94	4-way valve
Tho-S95	4-way valve
Tho-S96	4-way valve
Tho-S97	4-way valve
Tho-S98	4-way valve
Tho-S99	4-way valve
Tho-S100	4-way valve

Terminal block

Mark	Parts name
SW4-5	Spare
SW4-6	Spare
SW4-7	Address setting switch (master-slave)
SW4-8	Address setting switch (master-slave)
SW4-9	Address setting switch (master-slave)
SW4-10	Address setting switch (master-slave)
SW4-11	Address setting switch (master-slave)
SW4-12	Address setting switch (master-slave)
SW4-13	Address setting switch (master-slave)
SW4-14	Address setting switch (master-slave)
SW4-15	Address setting switch (master-slave)
SW4-16	Address setting switch (master-slave)
SW4-17	Address setting switch (master-slave)
SW4-18	Address setting switch (master-slave)
SW4-19	Address setting switch (master-slave)
SW4-20	Address setting switch (master-slave)
SW4-21	Address setting switch (master-slave)
SW4-22	Address setting switch (master-slave)
SW4-23	Address setting switch (master-slave)
SW4-24	Address setting switch (master-slave)
SW4-25	Address setting switch (master-slave)
SW4-26	Address setting switch (master-slave)
SW4-27	Address setting switch (master-slave)
SW4-28	Address setting switch (master-slave)
SW4-29	Address setting switch (master-slave)
SW4-30	Address setting switch (master-slave)
SW4-31	Address setting switch (master-slave)
SW4-32	Address setting switch (master-slave)
SW4-33	Address setting switch (master-slave)
SW4-34	Address setting switch (master-slave)
SW4-35	Address setting switch (master-slave)
SW4-36	Address setting switch (master-slave)
SW4-37	Address setting switch (master-slave)
SW4-38	Address setting switch (master-slave)
SW4-39	Address setting switch (master-slave)
SW4-40	Address setting switch (master-slave)
SW4-41	Address setting switch (master-slave)
SW4-42	Address setting switch (master-slave)
SW4-43	Address setting switch (master-slave)
SW4-44	Address setting switch (master-slave)
SW4-45	Address setting switch (master-slave)
SW4-46	Address setting switch (master-slave)
SW4-47	Address setting switch (master-slave)
SW4-48	Address setting switch (master-slave)
SW4-49	Address setting switch (master-slave)
SW4-50	Address setting switch (master-slave)
SW4-51	Address setting switch (master-slave)
SW4-52	Address setting switch (master-slave)
SW4-53	Address setting switch (master-slave)
SW4-54	Address setting switch (master-slave)
SW4-55	Address setting switch (master-slave)
SW4-56	Address setting switch (master-slave)
SW4-57	Address setting switch (master-slave)
SW4-58	Address setting switch (master-slave)
SW4-59	Address setting switch (master-slave)
SW4-60	Address setting switch (master-slave)
SW4-61	Address setting switch (master-slave)
SW4-62	Address setting switch (master-slave)
SW4-63	Address setting switch (master-slave)
SW4-64	Address setting switch (master-slave)
SW4-65	Address setting switch (master-slave)
SW4-66	Address setting switch (master-slave)
SW4-67	Address setting switch (master-slave)
SW4-68	Address setting switch (master-slave)
SW4-69	Address setting switch (master-slave)
SW4-70	Address setting switch (master-slave)
SW4-71	Address setting switch (master-slave)
SW4-72	Address setting switch (master-slave)
SW4-73	Address setting switch (master-slave)
SW4-74	Address setting switch (master-slave)
SW4-75	Address setting switch (master-slave)
SW4-76	Address setting switch (master-slave)
SW4-77	Address setting switch (master-slave)
SW4-78	Address setting switch (master-slave)
SW4-79	Address setting switch (master-slave)
SW4-80	Address setting switch (master-slave)
SW4-81	Address setting switch (master-slave)
SW4-82	Address setting switch (master-slave)
SW4-83	Address setting switch (master-slave)
SW4-84	Address setting switch (master-slave)
SW4-85	Address setting switch (master-slave)
SW4-86	Address setting switch (master-slave)
SW4-87	Address setting switch (master-slave)
SW4-88	Address setting switch (master-slave)
SW4-89	Address setting switch (master-slave)
SW4-90	Address setting switch (master-slave)
SW4-91	Address setting switch (master-slave)
SW4-92	Address setting switch (master-slave)
SW4-93	Address setting switch (master-slave)
SW4-94	Address setting switch (master-slave)
SW4-95	Address setting switch (master-slave)
SW4-96	Address setting switch (master-slave)
SW4-97	Address setting switch (master-slave)
SW4-98	Address setting switch (master-slave)
SW4-99	Address setting switch (master-slave)
SW4-100	Address setting switch (master-slave)

Meaning of marks

Mark	Parts name
CH1	Crankcase heater
CM1	Compressor motor
CNA-Z	Connector
CI1	Current sensor
CI-1,2	Electrolytic capacitor
DM1	Diode module
EEPH1,2,3	Expansion valve for heating
EEFSC	Expansion valve for SC
F	Fuse
FMC1	Fan for IPM
FMC2	Fan for IPM
IPM1,2	Intelligent power module
IPM1,2	Set up model (off)
J1,3	External input select level / pulse
J1,4	Defrost start temp
J1,5	Defrost start temp
J1,6	Defrost start temp
LED1	Heat recovery unit
LED1 (INV)	Inspection (Red)
LED2	Normal (Yellow) / Flashing
LED3	Normal (Green)
LED5	Service (Green) for service
LE1,2	D.C. reactor

PCB004Z089

Models FDC475KXZRE1, 500KXZRE1, 560KXZRE1
FDC615KXZRE1, 670KXZRE1

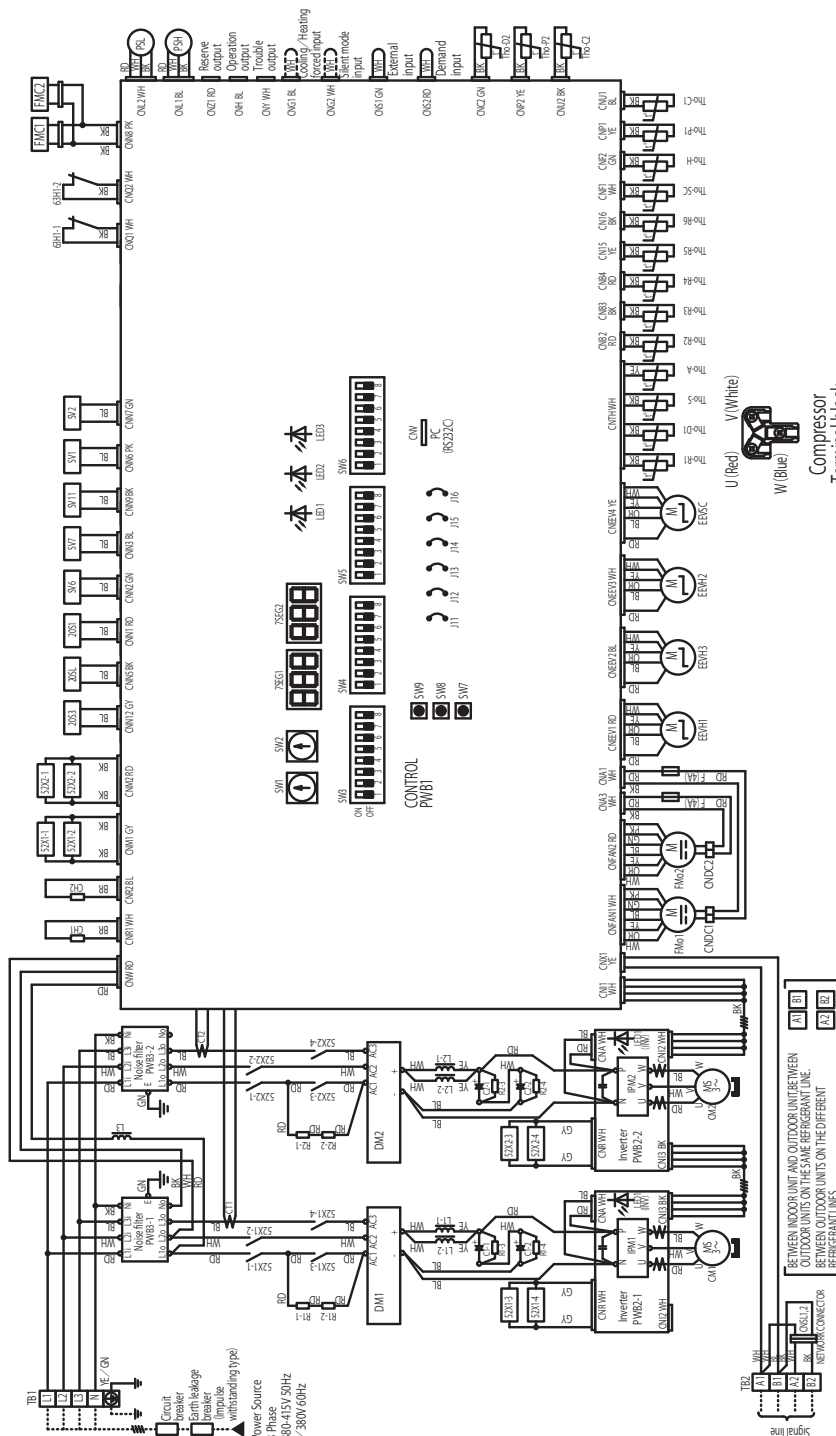

Meaning of marks

Mark	Parts name
CHI.2	Crankcase heater
CM1.2	Compressor motor
CNA.2	Connector
CI.1,CI.2	Current sensor
CI.1,CI.2.1	Electronic Capacitor
DM1.2	Diode module
EEHV1.2.3	Expansion valve for heating
F	Fuse
FMCI.2	Fan for PM
PMo.2	Blower motor
PM	Intelligent power module
J1.1,1.2	Set up model (volt)
J1.3	External input select level / pulse
J1.4	Defrost recover temp
J1.5	Defrost start temp
J1.6	Heat recovery unit
LED1 (INV)	Inspection (Red)
LED2 (Normal)	Normal (Yellow)
LED3 (Green)	Service (Green for service)
L-1.1,1.2,1.3	D.C reactor

Mark	Parts name
L3	D.C reactor
PSH	High pressure sensor
PSL	Low pressure sensor
PWB1.~3	Printed wiring board (PCB)
RA.1~2,4	Rich current suppression resistor
SV1	Solenoid valve (CM1 bypass)
SV2	Solenoid valve (CM2 bypass)
SV6	Solenoid valve (oil separator (CM1))
SV7	Solenoid valve (oil separator (CM2))
SV11	Solenoid valve (gas bypass)
SV12	Address setting SW outdoor unit (No.1,2 digits)
SV13	Address setting SW outdoor unit (No.1,2 digits)
SV14	Inspection, LED reset
SV15-2	ION Auto backup operation
SV15-3	OFF Regular operation
SV15-4	Spare
SV15-5	ION Superlink communication
SV15-6	Spare
SV15-7	ION Superlink communication
SV15-8	Spare
SV16-1~4	ION Check operation
SV17	OFF Regular operation
SV18	Spare
SV19	ION Check operation

Mark	Parts name
SW3-7	ON / OFF Forced cooling / heating
SW3-8	ON / OFF Regular operation
SW4	Spate
SW4-1~4	Model setting
SW4-5	Spate
SW4-6	Spate
SW4-7	Address setting switch (master-slave)
SW4-8	Address setting switch (master-slave)
SW5-1	ON / OFF Regular operation
SW5-2	ON / OFF Trial operation mode / cooling
SW5-3	ON / OFF Trial operation mode / heating
SW5-4	ON / OFF Pump down operation
SW5-5	ON / OFF Regular operation
SW5-6	Spate
SW5-7	ON / OFF Superlink communication
SW5-8	ON / OFF Superlink communication
SW5-9	Spate
SW6-1~4	Spate
SW7	Data clear / insert
SW8	7-segment indicate unit's place
SW9	7-segment indicate ten's place

Mark	Parts name
TBI.2	Terminal block
Tho-A	External air thermostat
Tho-C1.2	Under-dome thermostat
Tho-D1.2	Discharge pipe thermostat
Tho-H	Sub-cooling coil thermostat
Tho-P1.2	Power transistor thermostat
Tho-R1	Heat exchanger thermostat (exhaust)
Tho-R2	Heat exchanger thermostat (inlet)
Tho-R3	Heat exchanger thermostat (inlet)
Tho-R4	Heat exchanger thermostat (inlet)
Tho-R5	Heat exchanger thermostat (exhaust)
Tho-R6	Heat exchanger thermostat (inlet)
Tho-S	Suction pipe thermostat
ZOS1	4-way valve
ZOS2	4-way valve
ZOS3	4-way valve
ZOS4	4-way valve
ZOS5	4-way valve
ZOS6	4-way valve
ZOS7	4-way valve
ZOS8	4-way valve
ZOS9	4-way valve
ZOS10	4-way valve
ZOS11	4-way valve
ZOS12	4-way valve
ZOS13	4-way valve
ZOS14	4-way valve
ZOS15	4-way valve
ZOS16	4-way valve
ZOS17	4-way valve
ZOS18	4-way valve
ZOS19	4-way valve
ZOS20	4-way valve
ZOS21	4-way valve
ZOS22	4-way valve
ZOS23	4-way valve
ZOS24	4-way valve
ZOS25	4-way valve
ZOS26	4-way valve
ZOS27	4-way valve
ZOS28	4-way valve
ZOS29	4-way valve
ZOS30	4-way valve
ZOS31	4-way valve
ZOS32	4-way valve
ZOS33	4-way valve
ZOS34	4-way valve
ZOS35	4-way valve
ZOS36	4-way valve
ZOS37	4-way valve
ZOS38	4-way valve
ZOS39	4-way valve
ZOS40	4-way valve
ZOS41	4-way valve
ZOS42	4-way valve
ZOS43	4-way valve
ZOS44	4-way valve
ZOS45	4-way valve
ZOS46	4-way valve
ZOS47	4-way valve
ZOS48	4-way valve
ZOS49	4-way valve
ZOS50	4-way valve
ZOS51	4-way valve
ZOS52	4-way valve
ZOS53	4-way valve
ZOS54	4-way valve
ZOS55	4-way valve
ZOS56	4-way valve
ZOS57	4-way valve
ZOS58	4-way valve
ZOS59	4-way valve
ZOS60	4-way valve
ZOS61	4-way valve
ZOS62	4-way valve
ZOS63	4-way valve
ZOS64	4-way valve
ZOS65	4-way valve
ZOS66	4-way valve
ZOS67	4-way valve
ZOS68	4-way valve
ZOS69	4-way valve
ZOS70	4-way valve
ZOS71	4-way valve
ZOS72	4-way valve
ZOS73	4-way valve
ZOS74	4-way valve
ZOS75	4-way valve
ZOS76	4-way valve
ZOS77	4-way valve
ZOS78	4-way valve
ZOS79	4-way valve
ZOS80	4-way valve
ZOS81	4-way valve
ZOS82	4-way valve
ZOS83	4-way valve
ZOS84	4-way valve
ZOS85	4-way valve
ZOS86	4-way valve
ZOS87	4-way valve
ZOS88	4-way valve
ZOS89	4-way valve
ZOS90	4-way valve
ZOS91	4-way valve
ZOS92	4-way valve
ZOS93	4-way valve
ZOS94	4-way valve
ZOS95	4-way valve
ZOS96	4-way valve
ZOS97	4-way valve
ZOS98	4-way valve
ZOS99	4-way valve
ZOS100	4-way valve

Mark	Color
BK	Black
BL	Blue
BR	Brown
GN	Green
GY	Gray
OR	Orange
RD	Red
WH	White
YE	Yellow
PK	Pink
YE/GN	Yellow / Green

PCB004Z091

2.4 Noise level

Measured based on JIS B 8616

Mike position as highest noise level in position as below

Distance from front side 1m

Height 1m

Model FDC224KXZRE1

Noise level 55 dB (A) at cooling
57 dB (A) at heating

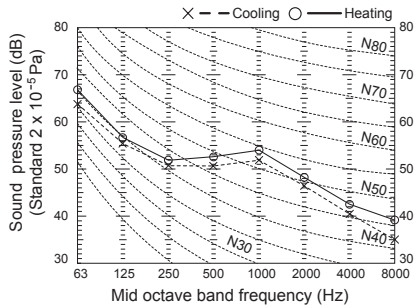

Model FDC280KXZRE1

Noise level 55 dB (A) at cooling
57 dB (A) at heating

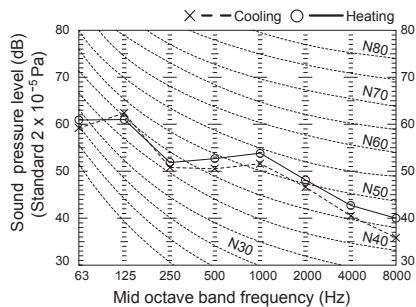

Model FDC335KXZRE1

Noise level 61 dB (A) at cooling
58 dB (A) at heating

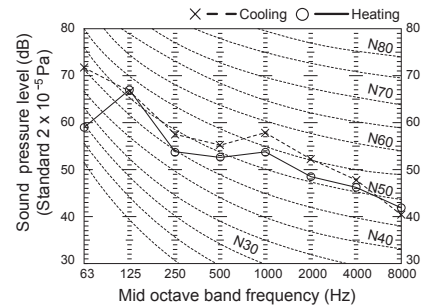

Model FDC400KXZRE1

Noise level 60 dB (A) at cooling
62 dB (A) at heating

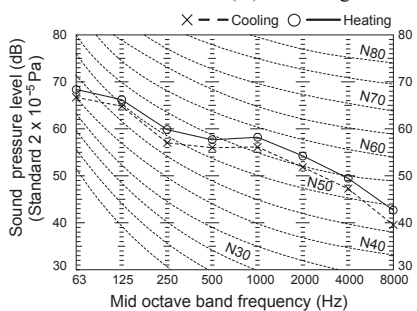

Model FDC450KXZRE1

Noise level 62 dB (A) at cooling
62 dB (A) at heating

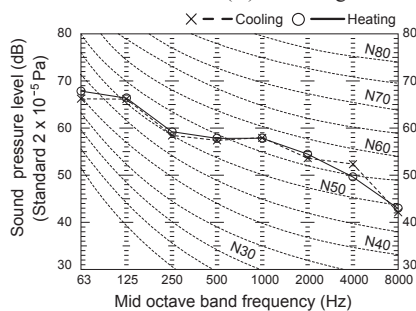

Model FDC475KXZRE1

Noise level 61 dB (A) at cooling
62 dB (A) at heating

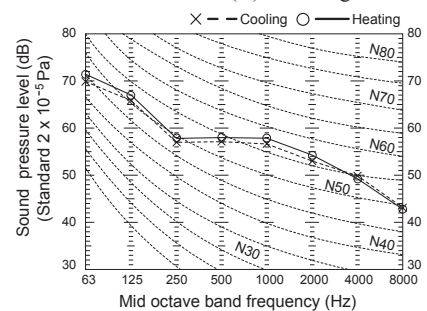

Model FDC500KXZRE1

Noise level 61 dB (A) at cooling
62 dB (A) at heating

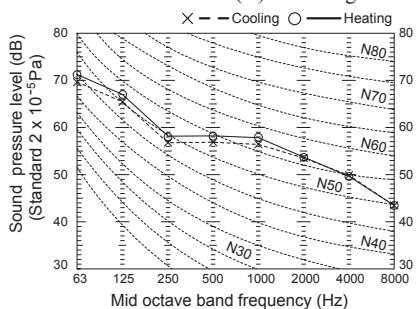

Model FDC560KXZRE1

Noise level 64 dB (A) at cooling
65 dB (A) at heating

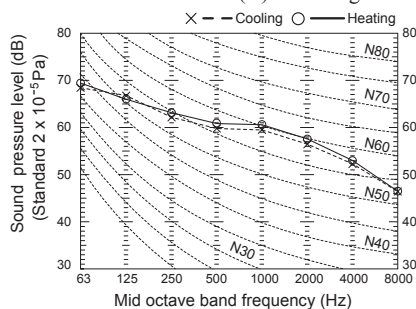

Model FDC615KXZRE1

Noise level 65 dB (A) at cooling
66 dB (A) at heating

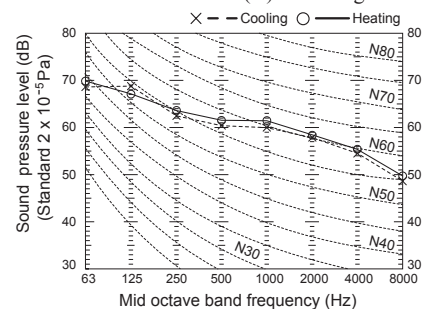

Model FDC670KXZRE1

Noise level 65 dB (A) at cooling
66 dB (A) at heating

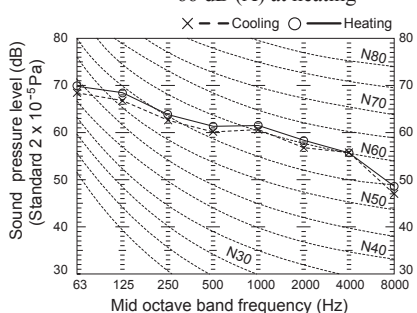

3. RANGE OF USAGE & LIMITATIONS

• Single use

Outdoor unit		FDC224KXZRE1	FDC280KXZRE1	FDC335KXZRE1
Item				
Indoor intake air temperature (Upper & lower limits)		Refer to page 27		
Outdoor air temperature (Upper & lower limits)		Refer to page 27		
Indoor unit	Number of connectable units	1 to 29 units	1 to 37 units	1 to 44 units
	Total connectable capacity ⁽¹⁾	112 - 448	140 - 560	167 - 670
Total piping length ⁽²⁾		1000m or less		
Main piping length (from outdoor unit to the first branching)		130m or less		
Maximum piping length from outdoor unit to the furthest indoor unit		Actual length : 160m or less, Equivalent length : 185m or less		
Allowable piping length from the first branching to the furthest indoor unit		90m or less (Difference between the longest and the shortest piping : 40m or less)		
Allowable piping length from the branching control (PFD box) to the indoor unit		40m or less		
Height difference between outdoor and indoor units	Outdoor unit is above	50m or less		
	Outdoor unit is below	40m or less ⁽³⁾		
Height difference between the indoor units		18m or less		
Height difference between the branching controls (PFD boxes)		18m or less		
Height difference between the first branching and the indoor unit		18m or less		
Height difference between the branching nearest to the branching control (PFD box) and the PFD box		Refer to note ⁽⁴⁾		
Height difference between the first branching and the branching control (PFD box)		18m or less		
Height difference between the branching control (PFD box) and the indoor unit	Indoor unit is above	1m or less		
	Indoor unit is below	4m or less		
Air flow volume and static pressure		Install the duct and air outlet grille with good insulation performance (arranged on site) within the range of fan characteristics. (for ducting models only such as FDU and etc)		
Air filter		Install air filter (arranged on site) at the place for easy maintenance (for ducting models only such as FDU and etc)		
Insulation of refrigerant piping		Insulation with 20mm or more thickness is required when the relative humidity exceeds 70% in such surroundings as inside of ceiling and etc.		
Insulation of drain piping		Insulation with 10mm or more thickness is required when the relative humidity exceeds 70% in such surroundings as inside of ceiling and etc.		
Indoor unit atmosphere (inside the ceiling) temperature and humidity { Only the models FDT, FDTc, FDTW, FDTs, FDTQ } { FDU, FDUm, FDQS and FDUH }		Dew-point temperature: 28°C or less, Relative humidity: 80% or less (for FDE, FDK, FDFL, FDFU, FDFW) Dew-point temperature: 23°C or less, Relative humidity: 80% or less		
Compressor start/stop frequency	Minimum operation cycle	5 minutes or more * Max. 12 min or more at low outdoor air temperatures (stop operation- start -stop or start operation-stop-start)		
	Minimum stopping period	3 minutes or more		
Power source voltage	Voltage fluctuation	Within ±10% of rated voltage		
	Voltage drop at starting	Within ±15% of rated voltage		
	Unbalance between phases	Within ±3% of rated voltage		

Notes (1) When connecting the indoor unit type FDK, FDFL, FDFU or FDFW series, the total connectable capacity should not exceed 130% of the outdoor unit capacity.

(2) When the total piping length exceeds 510m, 1000cc of additional refrigerant oil should be charged.

(3) When conducting cooling operation at 10°C or lower outdoor air temperature, it must be 30m or less.

(4) When all of following conditions (a) (b) and (c) are established, height difference between the branching nearest to the branching control (PFD box) and the PFD box should be limited to 4m or less.

(a) When the connected indoor unit model is 22 or 28.

(b) When the piping length from the first branching and the indoor unit is 40m or more.

(c) When the branching control (PFD box) is installed above the branching nearest to the PFD box.

In such case the size of discharge gas piping between the branching nearest to the branching control (PFD box) and the PFD box should be increased from $\phi 6.35$ to $\phi 9.52$.

(5) If Superlink I (previous Superlink) is selected, all the range of usage and limitations, not only the limitations of connectable indoor capacity and connectable number of indoor unit but also of the piping length, operating temperature range and etc., become same as those of KX4 (See technical manual '07 • KX • KXR-T-114). In addition to above limitations, all of new functions for KX6 such as automatic address setting function for multiple refrigerant systems and etc. will be cancelled.

Important

When the Additional refrigerant quantity for piping (P) is over the following table, please separate the refrigerant line.

Outdoor unit	Additional refrigerant charging amount
224-335	50

• Single use (For combination use as well)

Item		Outdoor unit	FDC400KXZRE1	FDC450KXZRE1	FDC475KXZRE1	FDC500KXZRE1
Indoor intake air temperature(Upper & lower limits)		Refer to page 27				
Outdoor air temperature(Upper & lower limits)		Refer to page 27				
Indoor unit	Number of connectable units	1 to 53 units	1 to 60 units	1 to 50 units	1 to 53 units	
	Total connectable capacity ⁽¹⁾	200 - 800	225 - 900	238 - 760	250 - 800	
Total piping length ⁽²⁾		1000m or less				
Main piping length (from outdoor unit to the first branching)		130m or less				
Maximum piping length from outdoor unit to the furthest indoor unit		Actual length : 160m or less, Equivalent length : 185m or less				
Allowable piping length from the first branching to the furthest indoor unit		90m or less (Difference between the longest and the shortest piping : 40m or less)				
Allowable piping length from the branching control (PFD box) to the indoor unit		40m or less				
Height difference between outdoor and indoor units	Outdoor unit is above	50m or less				
	Outdoor unit is below	40m or less ⁽³⁾				
Height difference between the indoor units		18m or less				
Height difference between the branching controls		18m or less				
Height difference between the first branching and the indoor unit		18m or less				
Height difference between the branching nearest to the branching control (PFD box) and the PFD box		Refer to note ⁽⁴⁾				
Height difference between the first branching and the branching control (PFD box)		18m or less				
Height difference between the branching control (PFD box) and the indoor unit	Indoor unit is above	1m or less				
	Indoor unit is below	4m or less				
Air flow volume and static pressure		Install the duct and air outlet grille with good insulation performance (arranged on site) within the range of fan characteristics. (for ducting models only such as FDU and etc)				
Air filter		Install air filter (arranged on site) at the place for easy maintenance (for ducting models only such as FDU and etc)				
Insulation of refrigerant piping		Insulation with 20mm or more thickness is required when the relative humidity exceeds 70% in such surroundings as inside of ceiling and etc.				
Insulation of drain piping		Insulation with 10mm or more thickness is required when the relative humidity exceeds 70% in such surroundings as inside of ceiling and etc.				
Indoor unit atmosphere (inside the ceiling) temperature [Only the models FDT, FDTC, FDTW, FDTs, FDTQ] [FDU, FDUM, FDQS and FDUH]		Dew-point temperature: 28°C or less, Relative humidity: 80% or less (for FDE, FDK, FDFL, FDFU, FDFW) Dew-point temperature: 23°C or less, Relative humidity: 80% or less				
Compressor start/stop frequency	Minimum operation cycle	5 minutes or more * Max. 12 min or more at low outdoor air temperatures (stop operation- start -stop or start operation-stop-start)				
	Minimum stopping period	3 minutes or more				
Power source voltage	Voltage fluctuation	Within ±10% of rated voltage				
	Voltage drop at starting	Within ±15% of rated voltage				
	Unbalance between phases	Within ±3% of rated voltage				

Notes (1) When connecting the indoor unit type FDK, FDFL, FDFU or FDFW series, the total connectable capacity should not exceed 130% of the outdoor unit capacity.

(2) When the total piping length exceeds 510m, 1000cc of additional refrigerant oil should be charged.

(3) When conducting cooling operation at 10°C or lower outdoor air temperature, it must be 30m or less.

(4) When all of following conditions (a) (b) and (c) are established, height difference between the branching nearest to the branching control (PFD box) and the indoor unit should be **limited to 4m or less**.

(a) When the connected indoor unit **model is 22 or 28**.

(b) When the piping length from the first branching and the indoor unit is **40m or more**.

(c) When the branching control (PFD box) is installed above the branching nearest to the PFD box.

In such case the size of discharge gas piping between the branching nearest to the branching control (PFD box) and the PFD box should be **increased from φ6.35 to φ9.52**.

(5) If Superlink I (previous Superlink) is selected, all the range of usage and limitations, not only the limitations of connectable indoor capacity and connectable number of indoor unit but also of the piping length, operating temperature range and etc., become same as those of KX4 (See technical manual '07 • KX • KXR-T-114). In addition to above limitations, all of new functions for KX6 such as automatic address setting function for multiple refrigerant systems and etc. will be cancelled.

Important

When the calculation result of additional refrigerant charging amount exceeds the value mentioned in following table, please split the refrigerant system into two.

Outdoor unit	Additional refrigerant charging amount
400-500	50

• Single use (For combination use as well)

Outdoor unit		FDC560KXZRE1	FDC615KXZRE1	FDC670KXZRE1
Item				
Indoor intake air temperature(Upper & lower limits)		Refer to page 27		
Outdoor air temperature(Upper & lower limits)		Refer to page 27		
Indoor unit	Number of connectable units	1 to 59 units	2 to 65 units	2 to 71 units
	Total connectable capacity ⁽¹⁾	280 - 896	308 - 984	335 - 1172
Total piping length ⁽²⁾		1000m or less		
Main piping length (from outdoor unit to the first branching)		130m or less		
Maximum piping length from outdoor unit to the furthest indoor unit		Actual length : 160m or less, Equivalent length : 185m or less		
Allowable piping length from the first branching to the furthest indoor unit		90m or less (Difference between the longest and the shortest piping : 40m or less)		
Allowable piping length from the branching control (PFD box) to the indoor unit		40m or less		
Height difference between outdoor and indoor units	Outdoor unit is above	50m or less		
	Outdoor unit is below	40m or less ⁽³⁾		
Height difference between the indoor units		18m or less		
Height difference between the branching controls		18m or less		
Height difference between the first branching and the branching control (PFD box) and the PFD box		18m or less		
Height difference between the branching nearest to the branching control (PFD box) and the PFD box		Refer to note ⁽⁴⁾		
Height difference between the first branching and the branching control (PFD box)		18m or less		
Height difference between the branching control (PFD box) and the indoor unit	Indoor unit is above	1m or less		
	Indoor unit is below	4m or less		
Air flow volume and static pressure		Install the duct and air outlet grille with good insulation performance (arranged on site) within the range of fan characteristics. (for ducting models only such as FDU and etc)		
Air filter		Install air filter (arranged on site) at the place for easy maintenance (for ducting models only such as FDU and etc)		
Insulation of refrigerant piping		Insulation with 20mm or more thickness is required when the relative humidity exceeds 70% in such surroundings as inside of ceiling and etc.		
Insulation of drain piping		Insulation with 10mm or more thickness is required when the relative humidity exceeds 70% in such surroundings as inside of ceiling and etc.		
Indoor unit atmosphere (inside the ceiling) temperature { Only the models FDT, FDTTC, FDTW, FDTs, FDTQ } { FDU, FDUM, FDQS and FDUH }		Dew-point temperature: 28°C or less, Relative humidity: 80% or less (for FDE, FDK, FDFL, FDFU, FDFW) Dew-point temperature: 23°C or less, Relative humidity: 80% or less		
Compressor start/stop frequency	Minimum operation cycle	5 minutes or more * Max. 12 min or more at low outdoor air temperatures (stop operation- start -stop or start operation-stop-start)		
	Minimum stopping period	3 minutes or more		
Power source voltage	Voltage fluctuation	Within ±10% of rated voltage		
	Voltage drop at starting	Within ±15% of rated voltage		
	Unbalance between phases	Within ±3% of rated voltage		

Notes (1) When connecting the indoor unit type FDK, FDFL, FDFU or FDFW series, the total connectable capacity should not exceed 130% of the outdoor unit capacity.

(2) When the total piping length exceeds 510m, 1000cc of additional refrigerant oil should be charged.

(3) When conducting cooling operation at 10°C or lower outdoor air temperature, it must be 30m or less.

(4) When all of following conditions (a) (b) and (c) are established, height difference between the branching nearest to the branching control (PFD box) and the indoor unit should be limited to 4m or less.

(a) When the connected indoor unit model is 22 or 28.

(b) When the piping length from the first branching and the indoor unit is 40m or more.

(c) When the branching control (PFD box) is installed above the branching nearest to the PFD box.

In such case the size of discharge gas piping between the branching nearest to the branching control (PFD box) and the PFD box should be increased from $\phi 6.35$ to $\phi 9.52$.

(5) If Superlink I (previous Superlink) is selected, all the range of usage and limitations, not only the limitations of connectable indoor capacity and connectable number of indoor unit but also of the piping length, operating temperature range and etc., become same as those of KX4 (See technical manual '07 • KX • KXR-T-114). In addition to above limitations, all of new functions for KX6 such as automatic address setting function for multiple refrigerant systems and etc. will be cancelled.

Important

When the calculation result of additional refrigerant charging amount exceeds the value mentioned in following table, please split the refrigerant system into two.

Outdoor unit	Additional refrigerant charging amount
560-670	50

• Combination use

		Outdoor unit	FDC735KXZRE1	FDC800KXZRE1	FDC850KXZRE1	FDC900KXZRE1	FDC950KXZRE1
Item							
Indoor intake air temperature(Upper & lower limits)		Refer to page 27					
Outdoor air temperature(Upper & lower limits)		Refer to page 27					
Indoor unit	Number of connectable units	2 to 78 units	2 to 80 units	2 to 80 units	2 to 80 units	2 to 80 units	2 to 80 units
	Total connectable capacity ⁽¹⁾	368 - 1176	400 - 1280	425 - 1360	450 - 1440	475 - 1520	
Total piping length ⁽²⁾		1000m or less					
Main piping length (from outdoor unit to the first branching)		130m or less					
Maximum piping length from outdoor unit to the furthest indoor unit		Actual length : 160m or less, Equivalent length : 185m or less					
Allowable piping length from the first branching to the furthest indoor unit		90m or less (Difference between the longest and the shortest piping : 40m or less)					
Allowable piping length from the branching control (PFD box) to the indoor unit		40m or less					
Height difference between outdoor and indoor units	Outdoor unit is above	50m or less					
	Outdoor unit is below	40m or less ⁽³⁾					
Height difference between the indoor units		18m or less					
Height difference between the branching controls		18m or less					
Height difference between the first branching and the indoor unit		18m or less					
Height difference between the branching nearest to the branching control (PFD box) and the PFD box		Refer to note ⁽⁴⁾					
Height difference between the first branching and the branching control (PFD box)		18m or less					
Height difference between the branching control (PFD box) and the indoor unit	Indoor unit is above	1m or less					
	Indoor unit is below	4m or less					
Height difference between master and slave outdoor units		0.4m or less ⁽⁶⁾					
Height difference between the outdoor unit and the outdoor side branching		5m or less					
Allowable piping length of oil equalization piping		10m or less					
Air flow volume and static pressure		Install the duct and air outlet grille with good insulation performance (arranged on site) within the range of fan characteristics. (for ducting models only such as FDU and etc)					
Air filter		Install air filter (arranged on site) at the place for easy maintenance (for ducting models only such as FDU and etc)					
Insulation of refrigerant piping		Insulation with 20mm or more thickness is required when the relative humidity exceeds 70% in such surroundings as inside of ceiling and etc.					
Insulation of drain piping		Insulation with 10mm or more thickness is required when the relative humidity exceeds 70% in such surroundings as inside of ceiling and etc.					
Indoor unit atmosphere (inside the ceiling) temperature and humidity { Only the models FDT, FDTC, FDTW, FDTS, FDTQ } { FDU, FDUM, FDQS and FDUH }		Dew-point temperature: 28°C or less, Relative humidity: 80% or less (for FDE, FDK, FDFL, FDFU, FDFW) Dew-point temperature: 23°C or less, Relative humidity: 80% or less					
Compressor start/stop frequency	Minimum operation cycle	5 minutes or more * Max. 12 min or more at low outdoor air temperatures (stop operation- start -stop or start operation-stop-start)					
	Minimum stopping period	3 minutes or more					
Power source voltage	Voltage fluctuation	Within ± 10% of rated voltage					
	Voltage drop at starting	Within ± 15% of rated voltage					
	Unbalance between phases	Within ± 3% of rated voltage					

Notes (1) When connecting the indoor unit type FDK, FDFL, FDFU or FDFW series, the total connectable capacity should not exceed 130% of the outdoor unit capacity.

(2) When the total piping length exceeds 510m, 1000cc of additional refrigerant oil should be charged.

(3) When conducting cooling operation at 10°C or lower outdoor air temperature, it must be 30m or less.

(4) When all of following conditions (a) (b) and (c) are established, height difference between the branching nearest to the branching control (PFD box) and the indoor unit should be limited to 4m or less.

(a) When the connected indoor unit model is 22 or 28.

(b) When the piping length from the first branching and the indoor unit is 40m or more.

(c) When the branching control (PFD box) is installed above the branching nearest to the PFD box.

In such case the size of discharge gas piping between the branching nearest to the branching control (PFD box) and the PFD box should be increased from φ 6.35 to φ 9.52.

(5) If Superlink I (previous Superlink) is selected, all the range of usage and limitations, not only the limitations of connectable indoor capacity and connectable number of indoor unit but also of the piping length, operating temperature range and etc., become same as those of KX4 (See technical manual '07 • KX • KXR-T-114). In addition to above limitations, all of new functions for KX6 such as automatic address setting function for multiple refrigerant systems and etc. will be cancelled.

(6) When using the outdoor units under 0°C, install them on the same level.

Important

When the calculation result of additional refrigerant charging amount exceeds the value mentioned in following table, please split the refrigerant system into two.

Outdoor unit	Additional refrigerant charging amount
730-950	100

• Combination use

Outdoor unit		FDC1000 KXZRE1	FDC1060 KXZRE1	FDC1120 KXZRE1	FDC1200 KXZRE1	FDC1250 KXZRE1	FDC1300 KXZRE1	FDC1350 KXZRE1
Item		Refer to page 27						
Indoor intake air temperature (Upper & lower limits)								
Outdoor air temperature (Upper & lower limits)								
Indoor unit	Number of connectable units	2 to 80 units	2 to 80 units	2 to 80 units	3 to 80 units	3 to 80 units	3 to 80 units	3 to 80 units
	Total connectable capacity ⁽¹⁾	500 - 1300	530 - 1378	560 - 1456	600 - 1560	625 - 1625	650 - 1690	675 - 1755
Total piping length ⁽²⁾		1000m or less						
Main piping length (from outdoor unit to the first branching)		130m or less						
Maximum piping length from outdoor unit to the furthest indoor unit		Actual length : 160m or less, Equivalent length : 185m or less						
Allowable piping length from the first branching to the furthest indoor unit		90m or less (Difference between the longest and the shortest piping : 40m or less)						
Allowable piping length from the branching control (PFD box) to the indoor unit		40m or less						
Height difference between outdoor and indoor units	Outdoor unit is above	50m or less						
	Outdoor unit is below	40m or less ⁽³⁾						
Height difference between the indoor units		18m or less						
Height difference between the branching controls		18m or less						
Height difference between the first branching and the indoor unit		18m or less						
Height difference between the branching nearest to the branching control (PFD box) and the PFD box		Refer to note ⁽⁴⁾						
Height difference between the first branching and the branching control (PFD box)		18m or less						
Height difference between the branching control (PFD box) and the indoor unit	Indoor unit is above	1m or less						
	Indoor unit is below	4m or less						
Height difference between master and slave outdoor units		0.4m or less ⁽⁶⁾						
Height difference between the outdoor unit and the outdoor side branching		5m or less						
Allowable piping length of oil equalization piping		10m or less						
Air flow volume and static pressure		Install the duct and air outlet grille with good insulation performance (arranged on site) within the range of fan characteristics. (for ducting models only such as FDU and etc)						
Air filter		Install air filter (arranged on site) at the place for easy maintenance (for ducting models only such as FDU and etc)						
Insulation of refrigerant piping		Insulation with 20mm or more thickness is required when the relative humidity exceeds 70% in such surroundings as inside of ceiling and etc.						
Insulation of drain piping		Insulation with 10mm or more thickness is required when the relative humidity exceeds 70% in such surroundings as inside of ceiling and etc.						
Indoor unit atmosphere (inside the ceiling) temperature and humidity (Only the models FDT, FDTC, FDTW, FDTS, FDTQ) [FDU, FDUM, FDQS and FDUH]		Dew-point temperature: 28°C or less, Relative humidity: 80% or less (for FDE, FDK, FDFL, FDFU, FDFW) Dew-point temperature: 23°C or less, Relative humidity: 80% or less						
Compressor start/stop frequency	Minimum operation cycle	5 minutes or more * Max. 12 min or more at low outdoor air temperatures (stop operation- start -stop or start operation-stop-start)						
	Minimum stopping period	3minutes or more						
Power source voltage	Voltage fluctuation	Within ±10% of rated voltage						
	Voltage drop at starting	Within ±15% of rated voltage						
	Unbalance between phases	Within ±3% of rated voltage						

Notes (1) When connecting the indoor unit type FDK, FDFL, FDFU or FDFW series, the total connectable capacity should not exceed 130% of the outdoor unit capacity.

(2) When the total piping length exceeds 510m, 1000cc of additional refrigerant oil should be charged.

(3) When conducting cooling operation at 10°C or lower outdoor air temperature, it must be 30m or less.

(4) When all of following conditions (a) (b) and (c) are established, height difference between the branching nearest to the branching control (PFD box) and the indoor unit should be limited to 4m or less.

(a) When the connected indoor unit model is 22 or 28.

(b) When the piping length from the first branching and the indoor unit is 40m or more.

(c) When the branching control (PFD box) is installed above the branching nearest to the PFD box.

In such case the size of discharge gas piping between the branching nearest to the branching control (PFD box) and the PFD box should be increased from φ6.35 to φ9.52.

(5) If Superlink I (previous Superlink) is selected, all the range of usage and limitations, not only the limitations of connectable indoor capacity and connectable number of indoor unit but also of the piping length, operating temperature range and etc., become same as those of KX4 (See technical manual '07 • KX • KXR-T-114). In addition to above limitations, all of new functions for KX6 such as automatic address setting function for multiple refrigerant systems and etc. will be cancelled.

(6) When using the outdoor units under 0°C, install them on the same level.

Important	
When the calculation result of additional refrigerant charging amount exceeds the value mentioned in following table, please split the refrigerant system into two.	
Outdoor unit	Additional refrigerant charging amount
1000-1350	100

• Combination use

Item	Outdoor unit	FDC1425 KXZRE1	FDC1450 KXZRE1	FDC1500 KXZRE1	FDC1560 KXZRE1	FDC1620 KXZRE1	FDC1680 KXZRE1
Indoor intake air temperature (Upper & lower limits)	Refer to page 27						
Outdoor air temperature (Upper & lower limits)	Refer to page 27						
Indoor unit	Number of connectable units	3 to 80 units	3 to 80 units	3 to 80 units	3 to 80 units	3 to 80 units	3 to 80 units
	Total connectable capacity ⁽¹⁾	713 - 1852	725 - 1885	750 - 1950	780 - 2028	810 - 2106	840 - 2184
Total piping length ⁽²⁾	1000m or less						
Main piping length (from outdoor unit to the first branching)	130m or less						
Maximum piping length from outdoor unit to the furthest indoor unit	Actual length : 160m or less, Equivalent length : 185m or less						
Allowable piping length from the first branching to the furthest indoor unit	90m or less (Difference between the longest and the shortest piping : 40m or less)						
Allowable piping length from the branching control (PFD box) to the indoor unit	40m or less						
Height difference between outdoor and indoor units	Outdoor unit is above	50m or less					
	Outdoor unit is below	40m or less ⁽³⁾					
Height difference between the indoor units	18m or less						
Height difference between the branching controls	18m or less						
Height difference between the first branching and the indoor unit	18m or less						
Height difference between the branching nearest to the branching control (PFD box) and the PFD box	Refer to note ⁽⁴⁾						
Height difference between the first branching and the branching control (PFD box)	18m or less						
Height difference between the branching control (PFD box) and the indoor unit	Indoor unit is above	1m or less					
	Indoor unit is below	4m or less					
Height difference between master and slave outdoor units	0.4m or less ⁽⁶⁾						
Height difference between the outdoor unit and the outdoor side branching	5m or less						
Allowable piping length of oil equalization piping	10m or less						
Air flow volume and static pressure	Install the duct and air outlet grille with good insulation performance (arranged on site) within the range of fan characteristics. (for ducting models only such as FDU and etc)						
Air filter	Install air filter (arranged on site) at the place for easy maintenance (for ducting models only such as FDU and etc)						
Insulation of refrigerant piping	Insulation with 20mm or more thickness is required when the relative humidity exceeds 70% in such surroundings as inside of ceiling and etc.						
Insulation of drain piping	Insulation with 10mm or more thickness is required when the relative humidity exceeds 70% in such surroundings as inside of ceiling and etc.						
Indoor unit atmosphere (inside the ceiling) temperature and humidity { Only the models FDT, FDTC, FDTW, FDTS, FDTQ } { FDU, FDUM, FDQS and FDUH }	Dew-point temperature: 28°C or less, Relative humidity: 80% or less (for FDE, FDK, FDFL, FDFU, FDFW) Dew-point temperature: 23°C or less, Relative humidity: 80% or less						
Compressor start/stop frequency	Minimum operation cycle	5 minutes or more * Max. 12 min or more at low outdoor air temperatures (stop operation- start -stop or start operation-stop-start)					
	Minimum stopping period	3 minutes or more					
Power source voltage	Voltage fluctuation	Within ±10% of rated voltage					
	Voltage drop at starting	Within ±15% of rated voltage					
	Unbalance between phases	Within ±3% of rated voltage					

Notes (1) When connecting the indoor unit type FDK, FDFL, FDFU or FDFW series, the total connectable capacity should not exceed 130% of the outdoor unit capacity.

(2) When the total piping length exceeds 510m, 1000cc of additional refrigerant oil should be charged.

(3) When conducting cooling operation at 10°C or lower outdoor air temperature, it must be 30m or less.

(4) When all of following conditions (a) (b) and (c) are established, height difference between the branching nearest to the branching control (PFD box) and the indoor unit should be limited to 4m or less.

(a) When the connected indoor unit model is 22 or 28.

(b) When the piping length from the first branching and the indoor unit is 40m or more.

(c) When the branching control (PFD box) is installed above the branching nearest to the PFD box.

In such case the size of discharge gas piping between the branching nearest to the branching control (PFD box) and the PFD box should be increased from $\phi 6.35$ to $\phi 9.52$.

(5) If Superlink I (previous Superlink) is selected, all the range of usage and limitations, not only the limitations of connectable indoor capacity and connectable number of indoor unit but also of the piping length, operating temperature range and etc., become same as those of KX4 (See technical manual '07 • KX • KXR-T-114). In addition to above limitations, all of new functions for KX6 such as automatic address setting function for multiple refrigerant systems and etc. will be cancelled.

(6) When using the outdoor units under 0°C, install them on the same level.

Important	
When the calculation result of additional refrigerant charging amount exceeds the value mentioned in following table, please split the refrigerant system into two.	
Outdoor unit	Additional refrigerant charging amount
1425-1680	100

Allowable length of refrigerant piping, height difference between indoor and outdoor unit

(a) Single use
1) Branching system

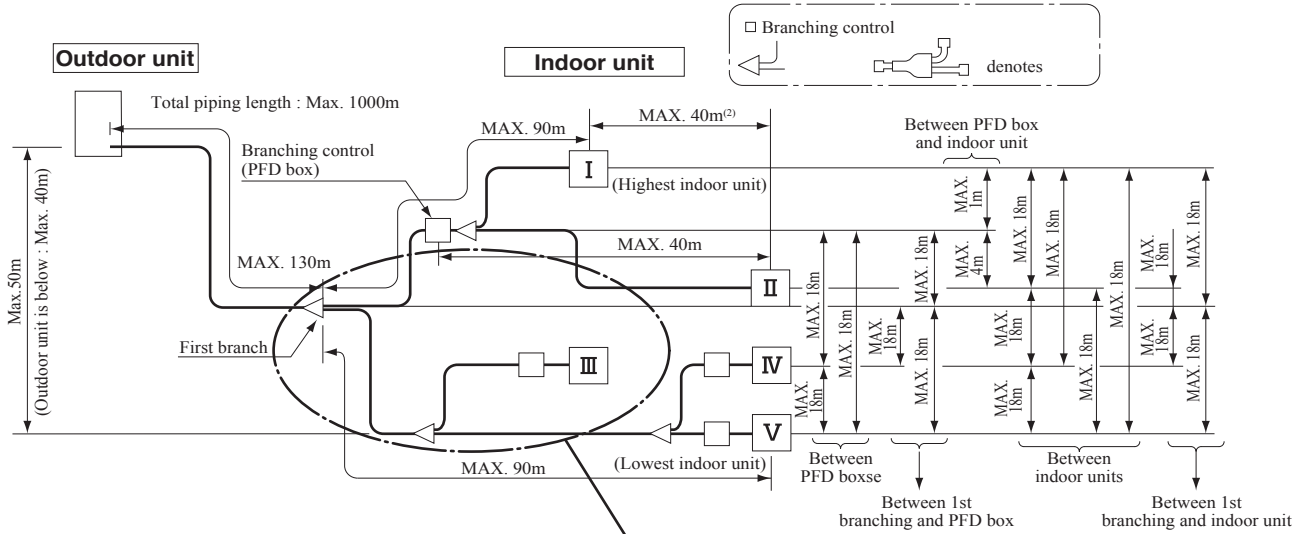

- Notes (1) When all of following conditions (a), (b) and (c) are established, height difference **A** shown in right figure is limited to **4m or less**.
- (a) When the connected indoor unit **model is 22 or 28**.
 - (b) When the piping length **B** is **40m or more**.
 - (c) When the PFD box is installed above the branching nearest to the PFD box.
- Size of discharge gas piping **C** should be increased from $\phi 6.35$ to $\phi 9.52$.
- (2) Do not install any large traps () or bumps () exceeded **500mm** in height in the piping system.
 - (3) Difference between the longest and shortest piping : **40m or less**.

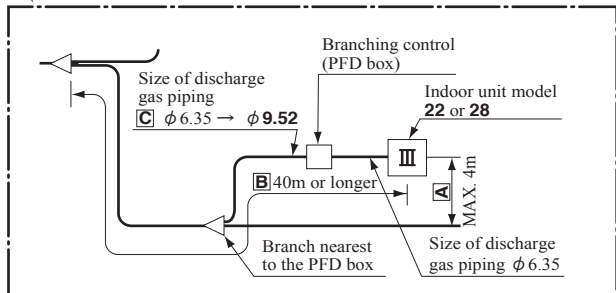

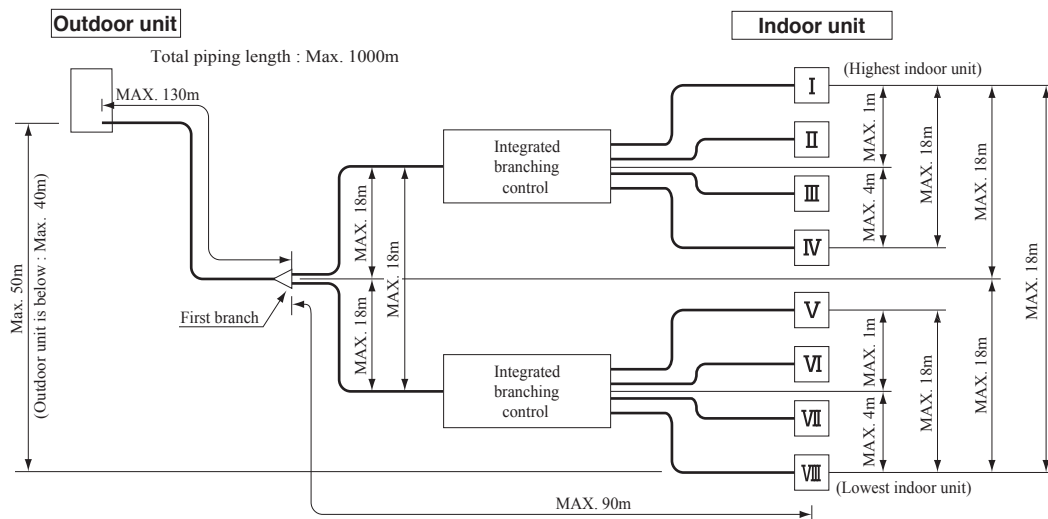

2) Integrated branching system

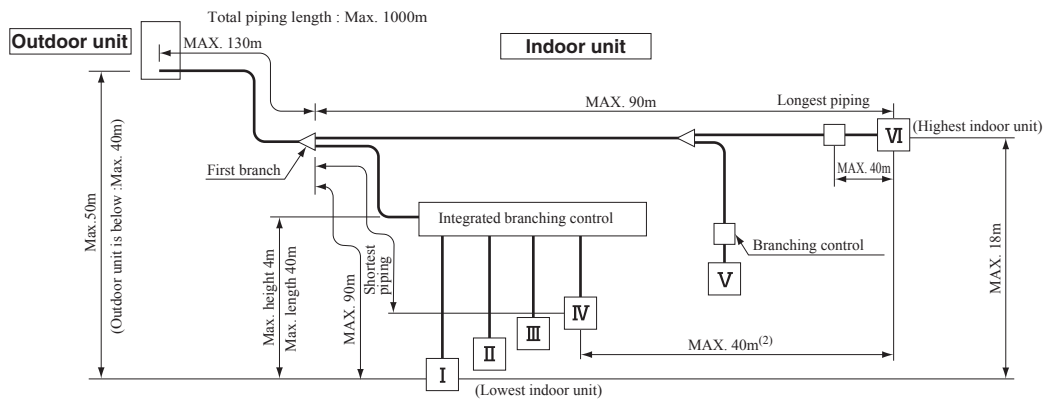

Note (1) Do not install any large traps () or bumps () exceeded **500mm** in height in the piping system.

3) Mixed system (Branching control and Integrated branching control)



- Notes (1) Do not install any large traps () or bumps () exceeded 500mm in height in the piping system.
 (2) Difference between the longest and shortest piping : 40m or less.

(b) Combination use

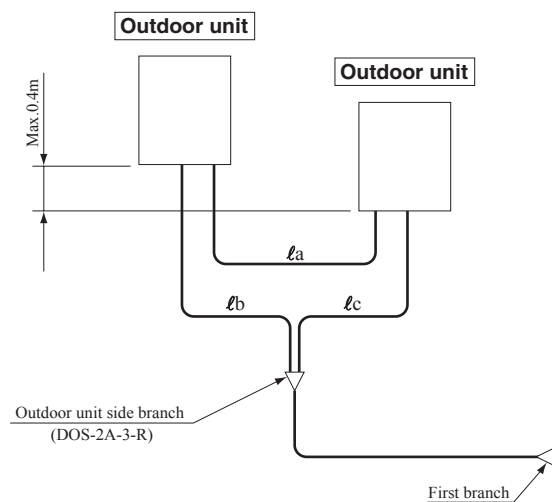

Allowable piping length

- Equalizing oil pipe $l_a \leq 10\text{m}$
- Refrigerant piping $l_b \leq 5\text{m}$
- Refrigerant piping $l_c \leq 5\text{m}$

- Notes (1) Limitations other than above are the same as that for the single use.
 (2) When using the outdoor units under 0°C, install them on the same level.

Operating temperature range

Cooling operation

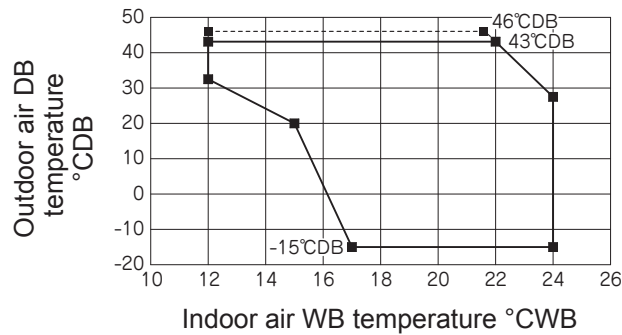

*In case it is the promised installation location that the outdoor unit is used on conditions with

Heating operation

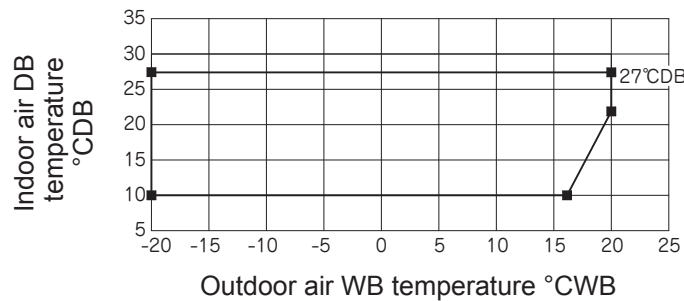

Note(1) Mixed operation of cooling/heating is prohibited with the outdoor air temperature at -5°C or lower.

“CAUTION” Cooling operation under low outdoor air temperature conditions

KXZR models can be operated in cooling mode at low outdoor air temperature condition within above temperature range.

However in case of severely low temperature conditions if the following precaution is not observed, it may not be operated in spite of operable temperature range mentioned above and cooling capacity may not be established under certain conditions.

[Precaution]

In case of severely low temperature condition

- 1) Install the outdoor unit at the place where strong wind cannot blow directly into the outdoor unit.
- 2) If there is no installation place where can prevent strong wind from directly blowing into the outdoor unit, prepare a windbreak fence or something like that locally in order to divert the strong wind from the outdoor unit.

[Reason]

Under the low outdoor air temperature conditions of -5°C or lower, if strong wind directly blow into the outdoor unit, the outdoor heat exchanger temperature will drop, even though the outdoor fan is stopped by outdoor fan control. This makes high and low pressures to drop as well. This low pressure drop makes the indoor heat exchanger temperature to drop and will activate anti-frost control at indoor heat exchanger at frequent intervals, that cooling operation may not be established for any given time.

4. PIPING SYSTEM

Models FDC224KXZRE1, 280KXZRE1, 335KXZRE1

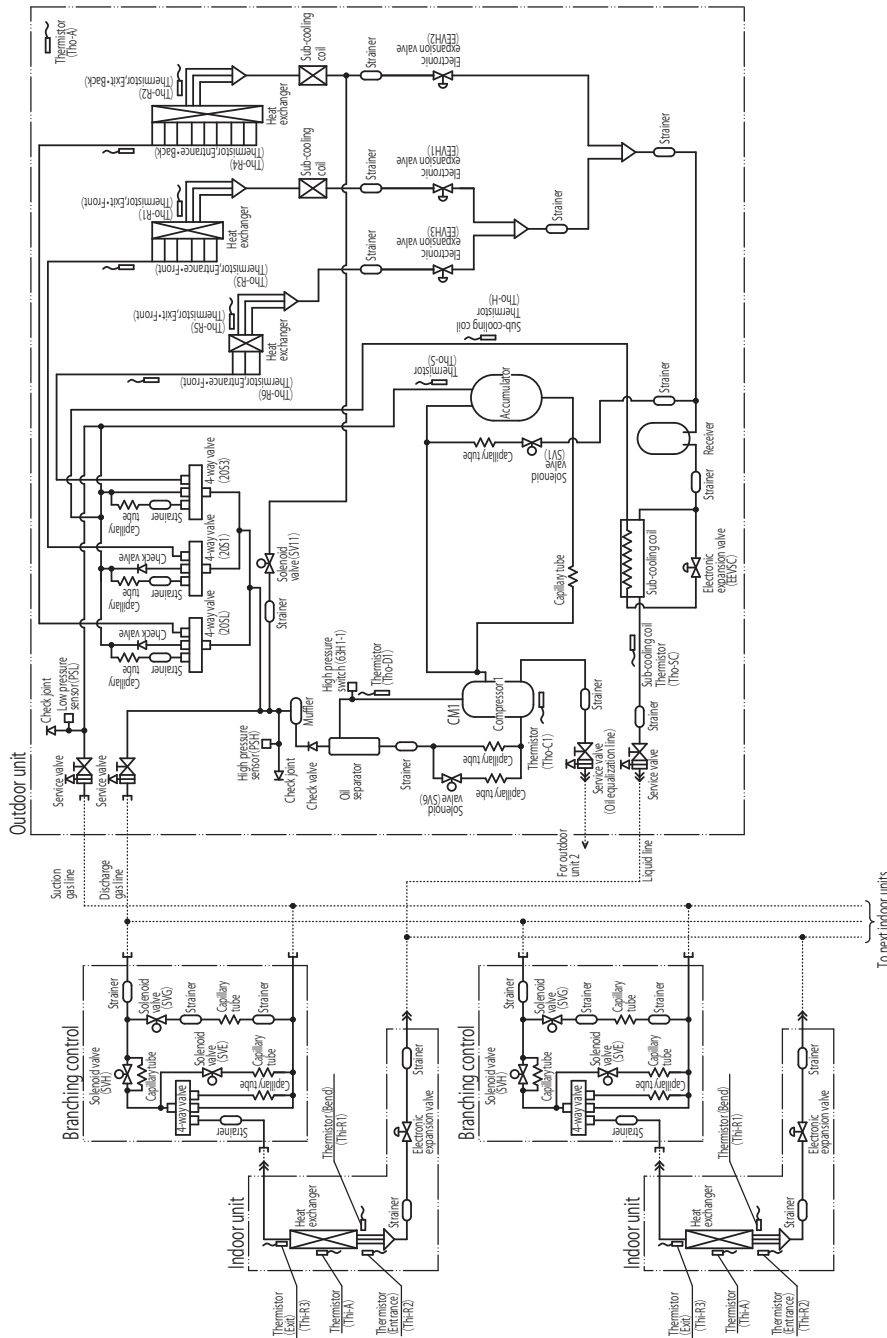

- Thi-R1, R2 : Heating operation : Indoor fan control.
- Cooling operation : Frost prevention control.
- Super heat control.
- Thi-R3 : For super heat control of cooling operation.
- Tho-D : For control of discharge pipe temperature.
- Tho-C : For control of temperature under the dome.
- Tho-S : For control of suction pipe temperature.
- Tho-R1,R2,R5 : For control of defrost operation.
- Tho-A : For control of defrost operation.
- Tho-R3, R4,R6 : Electronic expansion valve (EEVH1, 2) control of heating operation.
- Tho-SC : Electronic expansion valve (EEVSC) control of cooling operation.
- Tho-H : For super heat control of sub-cooling coil.

- Notes (1) Preset point of protective devices
63HI-1 : Open 4.15MPa, Close 3.15MPa
(For protection)
- (2) Function of thermistor
PSH : For compressor control
 3.70 ON (MPa)
PSL : ON 0.18MPa, OFF 0.20MPa
(For compressor control)
 ON 0.134MPa, OFF 0.18MPa
(For protection)

PCB004Z092

Models FDC400KXZRE1, 450KXZRE1

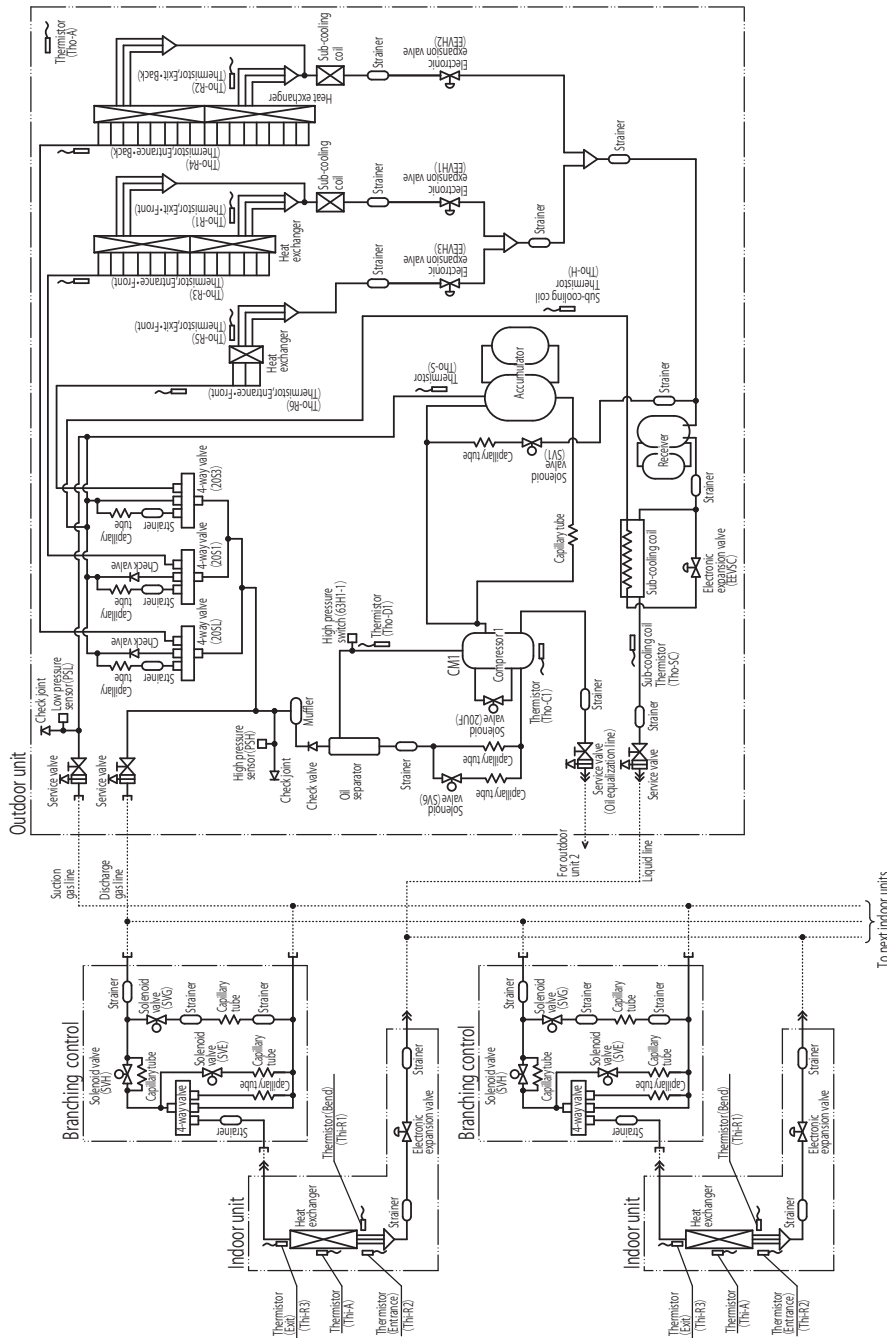

- Notes (1) Preset point of protective devices
 63H1-1 : Open 4.15MPa, Close 3.15MPa
 (For protection)
- (2) Function of thermistor
 PSH : For compressor control
 3.70 ON (MPa)
 PSL : ON 0.18MPa, OFF 0.20MPa
 (For compressor control)
 ON 0.134MPa, OFF 0.18MPa
 (For protection)

- Thi-R1, R2 : Heating operation : Indoor fan control.
 Cooling operation : Frost prevention control.
 Super heat control.
- Thi-R3 : For super heat control of cooling operation.
- Tho-D : For control of discharge pipe temperature.
- Tho-C : For control of temperature under the dome.
- Tho-S : For control of suction pipe temperature.
- Tho-R1,R2,R5 : For control of defrost operation.
- Tho-A : For control of defrost operation.
- Tho-R3, R4,R6 : Electronic expansion valve (EEVH1, 2) control of heating operation.
- Tho-SC : Electronic expansion valve (EEVSC) control of cooling operation.
- Tho-H : For super heat control of sub-cooling coil.

PCB004Z093

**Models FDC475KXZRE1, 500KXZRE1, 560KXZRE1
FDC615KXZRE1, 670KXZRE1**

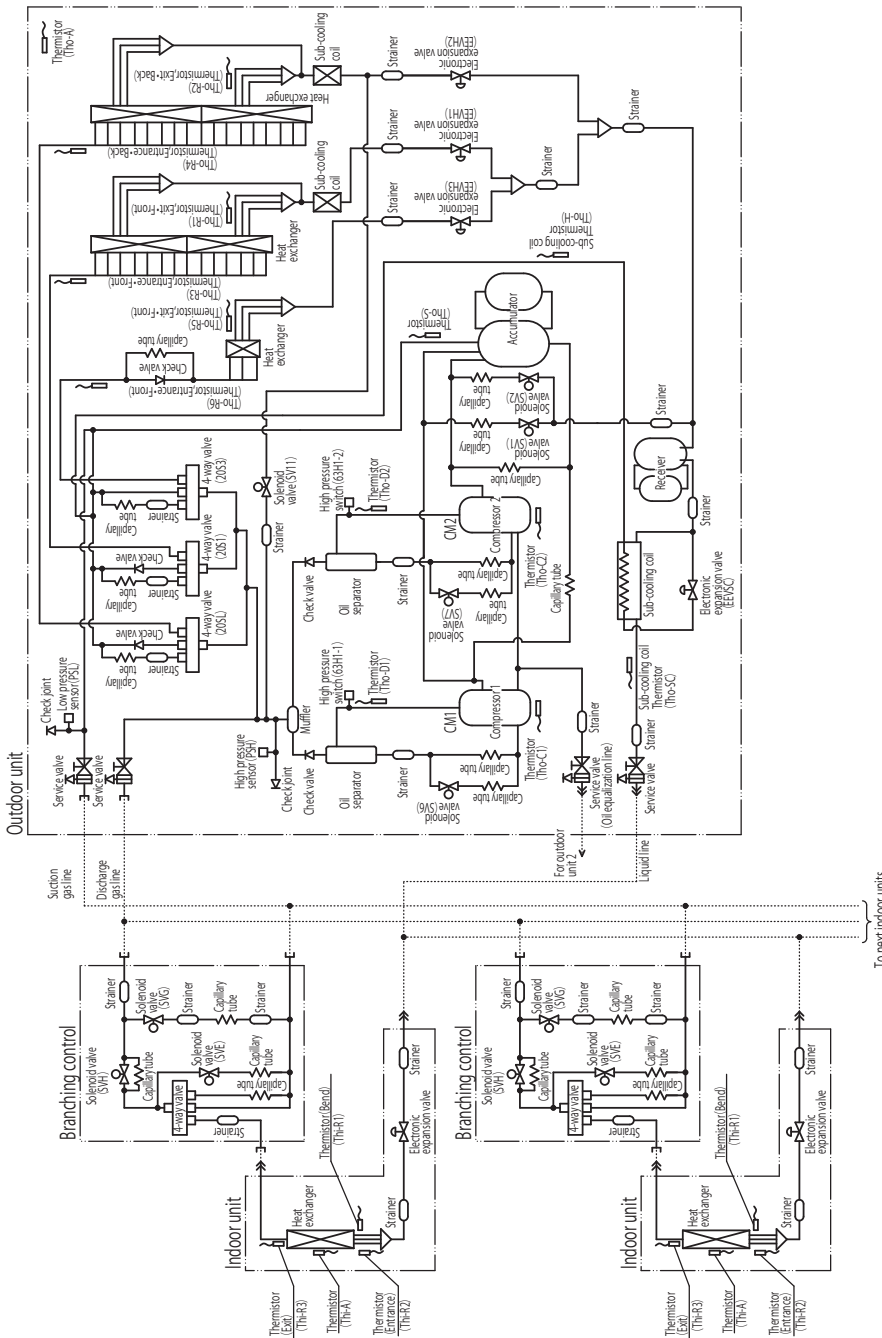

- Notes (1) Preset point of protective devices**
 63HI-1, 2 : Open 4.15MPa, Close 3.15MPa
 (For protection)
- (2) Function of thermistor**
 PSH : For compressor control
 3.70 ON (MPa)
 PSL : ON 0.18MPa, OFF 0.20MPa
 (For compressor control)
 ON 0.134MPa, OFF 0.18MPa
 (For protection)

- Thi-R1, R2 : Heating operation : Indoor fan control.
 Cooling operation : Frost prevention control.
 Super heat control.
- Thi-R3 : For super heat control of cooling operation.
 Tho-D1, D2 : For control of discharge pipe temperature.
 Tho-C1, C2 : For control of temperature under the dome.
 Tho-S : For control of suction pipe temperature.
 Tho-R1, R2, R5 : For control of defrost operation.
 Tho-A : For control of defrost operation.
 Tho-R3, R4, R6 : Electronic expansion valve (EEVH1, 2) control of heating operation.
 Tho-SC : Electronic expansion valve (EEVSC) control of cooling operation.
 Tho-H : For super heat control of sub-cooling coil.

PCB004Z094

5. SELECTION CHART

(1) Equipment selection flow

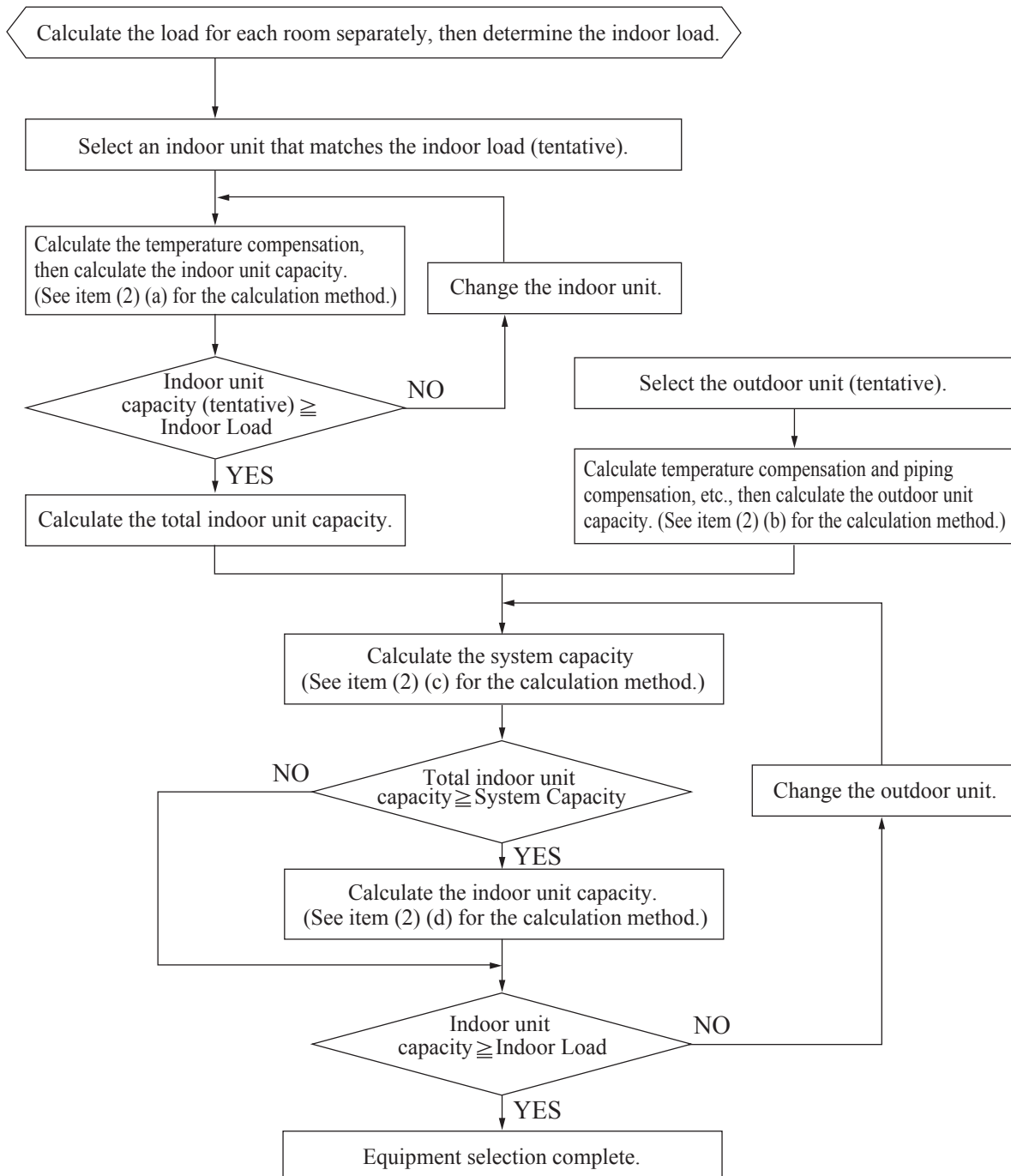

(2) Capacity calculation method

(a) Calculating the indoor unit capacity compensation

Indoor unit capacity (cooling, heating) = Indoor unit total rated capacity

× Capacity compensation coefficient according to temperature conditions

See item (3) (a) concerning the capacity compensation coefficient according to temperature conditions.

(b) Calculating the outdoor unit capacity compensation

Outdoor Unit Capacity (Cooling, Heating) = Outdoor unit rated capacity (rated capacity when 100% connected)

× Capacity compensation coefficient according to temperature conditions

× Capacity compensation coefficient according to piping length

× Capacity compensation coefficient according to height difference

- × Correction of heating capacity in relation to the frost on the outdoor unit heat exchanger
- × Capacity compensation coefficient according to indoor unit connection capacity
- × Correction of cooling capacity in relation to the anti-frost on the indoor unit heat exchanger

- ① See item (3) (a) concerning the capacity compensation coefficient according to temperature conditions.
- ② See item (3) (b) concerning the capacity compensation coefficient according to piping length.
- ③ See item (3) (c) concerning the capacity compensation coefficient according to height difference. This compensation should be carried out only in cases where the outdoor unit is lower during cooling and higher during heating.
- ④ See item (3) (d) correction of heating capacity in relation to the frost on the outdoor unit heat exchanger. This compensation should be carried out only when calculating the heating capacity.
- ⑤ See item (3) (e) concerning the capacity compensation coefficient according to indoor unit connected capacity. This compensation should be carried out only in cases where the indoor unit total capacity is 100% or higher.
- ⑥ See item (3) (f) correction of cooling capacity in relation to the anti-frost on the indoor unit heat exchanger. This compensation should be carried out only when calculating the cooling capacity.

(c) Calculating system capacity

Compare the capacities determined in items (a) and (b) above and let the smaller value be the system capacity (cooling, heating).

- ① In cases where indoor unit total capacity (cooling, heating) > outdoor unit capacity (cooling, heating)
System capacity (cooling, heating) = Outdoor unit capacity (cooling, heating)
- ② In cases where indoor unit total capacity (cooling, heating) < outdoor unit capacity (cooling, heating)
System capacity (cooling, heating) = Indoor unit capacity (cooling, heating)

(d) Calculating indoor unit capacity [item (c) ① only]

Indoor unit capacity (cooling, heating) = System capacity (cooling, heating)
× [(Indoor unit capacity) / (Indoor unit total capacity)]

Capacity calculation examples

Example 1

Cooling (when the indoor unit connected total capacity is less than 100%)

- Outdoor unit FDC450KXZRE1 1 Unit
- Indoor unit FDT56KXE6F 7 Units, All fan tap: P-Hi
- Piping length 60 m (Equivalent length)
- Indoor, outdoor unit height difference 15 m (Outdoor unit is lower)
- Temperature conditions Outdoor temperature: 33°C DB
- Temperature conditions Indoor temperature: 19°C WB

<Indoor unit total cooling capacity>: Item (2) (a) calculation.

- Indoor unit rated cooling capacity: 5.6 kW
- Capacity compensation coefficient according to temperature conditions:
1.02 (Calculated according to Indoor 19°C WB / Outdoor 33°C DB); (See page 34)
Indoor unit cooling capacity: 5.6 kW × 1.02 ≈ 5.7 kW
- Indoor unit total cooling capacity calculation;
indoor unit total cooling capacity: 5.7 kW × 7 units = 39.9 kW

<Outdoor unit maximum cooling capacity> : Item (2) (b) calculation

- Outdoor unit rated cooling capacity: 45.0 kW
- Capacity compensation coefficient according to temperature conditions:
1.02 (Calculated according to Indoor 19°C WB / Outdoor 33°C DB); (See page 34)
Outdoor unit cooling capacity: 45.0 kW × 1.02 ≈ 45.9 kW
- Capacity compensation coefficient according to piping length: 0.94 (calculated according to 60 m length); (See page 37)
45.9 kW × 0.94 ≈ 43.1 kW
- Correction of cooling capacity in relation to the anti-frost: 1.0 (calculated according to outdoor 33°C DB, Total capacity of concurrently operating indoor unit: $(56 \times 7) / 450 \approx 87\%$); (See page 55)
Outdoor unit cooling capacity: 43.1 kW × 1.0 ≈ 43.1 kW
- Capacity compensation coefficient according to height difference: 0.97 (calculated according to 15 m difference); (See page 40)
43.1 kW × 0.97 ≈ 41.8 kW
- Capacity compensation coefficient according to indoor unit connected total capacity: 1.0 ← $(56 \times 7) / 450 < 100\%$
No compensation

<System cooling capacity>: Item (2) (c) calculation

Compare the indoor unit total cooling capacity and the outdoor unit maximum cooling capacity. The smaller value is the actual system cooling capacity.

- Indoor unit total cooling capacity: 39.9 kW
 - Outdoor unit maximum cooling capacity: 41.8 kW
- ⇒ System cooling capacity: 39.9 kW

<Indoor unit capacity compensation> No compensation (5.7 kW)

Example 2

Cooling (when the indoor unit connected total capacity is 100% or higher)

- Outdoor unit FDC450KXZRE1 1 Unit
- Indoor unit FDT56KXE6F 10 Units, All fan tap: P-Hi
- Piping length 60 m (Equivalent length)
- Indoor, outdoor unit height difference 15 m (Outdoor unit is higher)
- Temperature conditions Outdoor temperature: 35°C DB
- Temperature conditions Indoor temperature: 18°C WB

<Indoor unit total cooling capacity>: Item (2) (a) calculation.

- Indoor unit rated cooling capacity: 5.6 kW
- Capacity compensation coefficient according to temperature conditions:
0.95 (Calculated according to Indoor 18°C WB / Outdoor 35°C DB); (See page 34)
- Indoor unit cooling capacity: 5.6 kW × 0.95 = 5.3 kW
- Indoor unit total cooling capacity calculation;
indoor unit total cooling capacity: 5.3 kW × 10 units = 53.0 kW

<Outdoor unit maximum cooling capacity> : Item (2) (b) calculation

- Outdoor unit rated cooling capacity: 45.0 kW
- Capacity compensation coefficient according to temperature conditions:
0.95 (Calculated according to Indoor 18°C WB / Outdoor 35°C DB); (See page 34)
- Outdoor unit cooling capacity: 45.0 kW × 0.95 = 42.8 kW
- Capacity compensation coefficient according to piping length: 0.94 (calculated according to 60 m length); (See page 37)
- 42.8 kW × 0.94 = 40.2 kW
- Collection of cooling capacity in relation to the anti-frost: 1.0 (calculated according to outdoor 35°C DB, Total capacity of concurrently operating indoor unit: (56 × 10) / 450 = 124%)
- 40.2 kW × 1.0 = 40.2 kW
- Capacity compensation coefficient according to height difference: 1.0 (the outdoor unit is higher during cooling)
- No compensation
- Capacity compensation coefficient according to indoor unit connected total capacity: 1.04 ← (56 × 10) / 450 = 124% (See page 43)
- 40.2 kW × 1.04 = 41.8 kW

<System cooling capacity>: Item (2) (c) calculation

Compare the indoor unit total cooling capacity and the outdoor unit maximum cooling capacity. The smaller value is the actual system cooling capacity.

- Indoor unit total cooling capacity : 53.0 kW
 - Outdoor unit maximum cooling capacity : 41.8 kW
- ⇒ System cooling capacity: 41.8 kW

<Indoor unit cooling capacity Compensation>: Item (2) (d) calculation.

$$\frac{41.8 \text{ kW} \times 5.3 \text{ kW}}{53.0 \text{ kW}} = \underline{4.2 \text{ kW}}$$

Example 3

Heating (when the indoor unit connected total capacity is 100% or higher)

- Outdoor unit FDC450KXZRE1 1 Unit
- Indoor unit FDT56KXE6F 10 Units
- Piping length 60 m (Equivalent length)
- Indoor, outdoor unit height difference 20 m (Outdoor unit is higher)
- Temperature conditions Outdoor temperature: 6°C WB
- Temperature conditions Indoor temperature: 19°C DB

<Indoor unit total heating capacity>: Item (2) (a) calculation.

- Indoor unit rated heating capacity: 6.3 kW
- Capacity compensation coefficient according to temperature conditions:
1.04 (Calculated according to Outdoor 6°C WB / Indoor 19°C DB); (See page 35)
- Indoor unit heating capacity: 6.3 kW × 1.04 = 6.6 kW
- Indoor unit total heating capacity calculation;
indoor unit total heating capacity: 6.6 kW × 10 units = 66.0 kW

<Outdoor unit maximum heating capacity> : Item (2) (b) calculation

- Outdoor unit rated heating capacity: 50.0 kW Correct the heating capacity based on the maximum capacity.
- Capacity compensation coefficient according to temperature conditions:
1.04 (Calculated according to Outdoor 6°C WB / Indoor 19°C DB); (See page 35)
Outdoor unit heating capacity: 50.0 kW × 1.04 = 52.0 kW
- Capacity compensation coefficient according to piping length: 0.975 (calculated according to 60 m length); (See page 40)
52.0 kW × 0.975 = 50.7 kW
- Capacity compensation coefficient according to height difference: 0.96 (calculated according to 20 m difference); (See page 40)
50.7 kW × 0.96 = 48.7 kW
- Correction of heating capacity in relation to the frost on the outdoor unit heat exchanger:
1.0 (calculated according to 6°C WB); (See page 40)
48.7 kW × 1.0 = 48.7 kW.
- Capacity compensation coefficient according to indoor unit connected total capacity: 1.0 ← (56 × 10) / 450 = 124% (See page 43)
48.7 kW × 1.0 = 48.7 kW.

<System heating capacity> : Item (2) (c) calculation

Compare the indoor unit total heating capacity and the outdoor unit maximum heating capacity. The smaller value is the actual system heating capacity.

- Indoor unit total heating capacity : 66.0 kW ⇒ System heating capacity: 48.7 kW
- Outdoor unit maximum heating capacity : 48.7 kW

<Indoor unit heating capacity compensation> : Item (2) (d) calculation

$$\frac{48.7 \text{ kW} \times 6.6 \text{ kW}}{66.0 \text{ kW}} = \underline{4.9 \text{ kW}}$$

(3) Capacity compensation coefficient

(a) Capacity compensation coefficient and power consumption compensation coefficient according to indoor and outdoor temperature conditions.

1) Capacity compensation coefficient

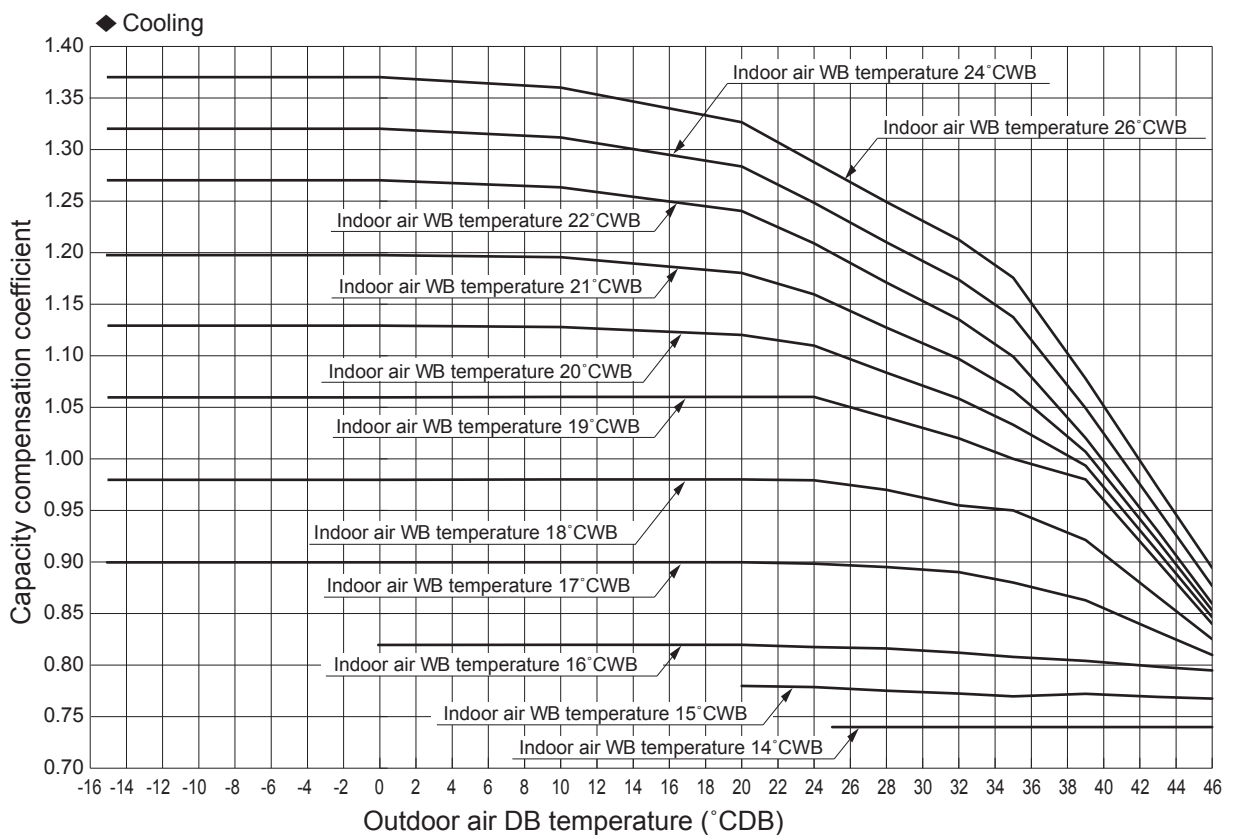

- Notes (1) The above-mentioned table shows a typical condition among conditions to occur via controlling an air-conditioning equipment.
 (2) When performing the cooling operation with the outdoor air temperature being -5°C or under, a windbreak fence must be installed.
 (3) The cooling capacity might decrease due to the anti-frost control and decreased refrigerant circulation volume in low outdoor temperature. Please avoid using the air-conditioners for computer rooms or industrial uses which require annual cooling operation.
 (4) Oil-return control might be performed every few minutes in order to protect the compressor. If this occurs, the expected capacity might not be output.

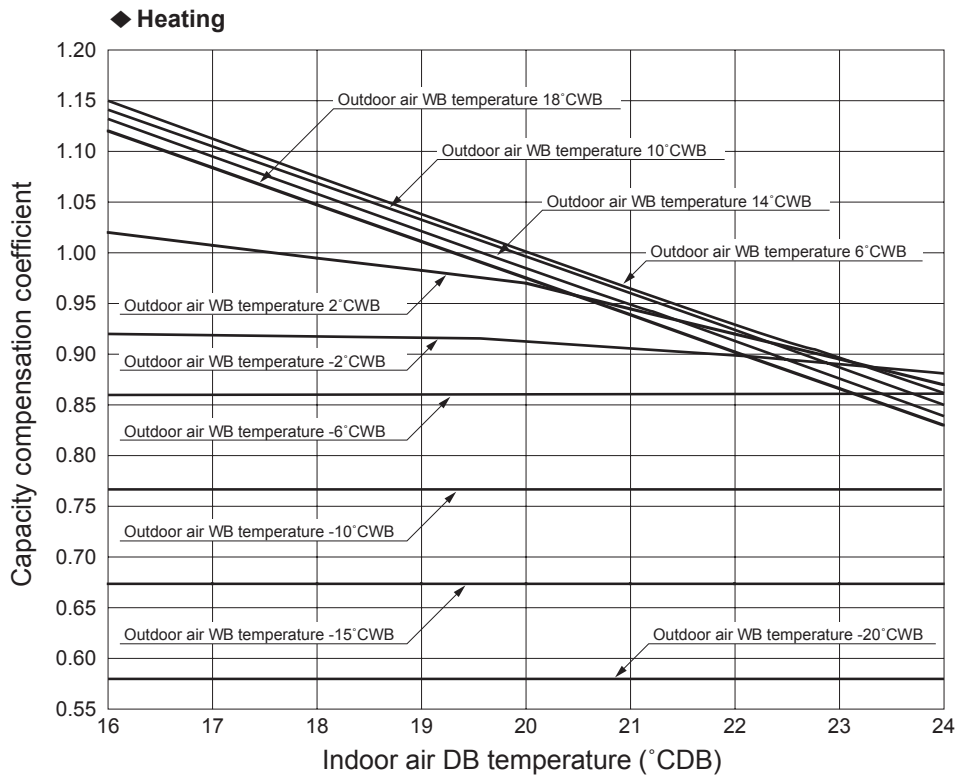

Notes (1) The above-mentioned table shows a typical condition among conditions to occur via controlling an air-conditioning equipment.
 (2) Oil-return control might be performed every few minutes in order to protect the compressor. If this occurs, the expected capacity might not be output.

2) Power consumption correction factor

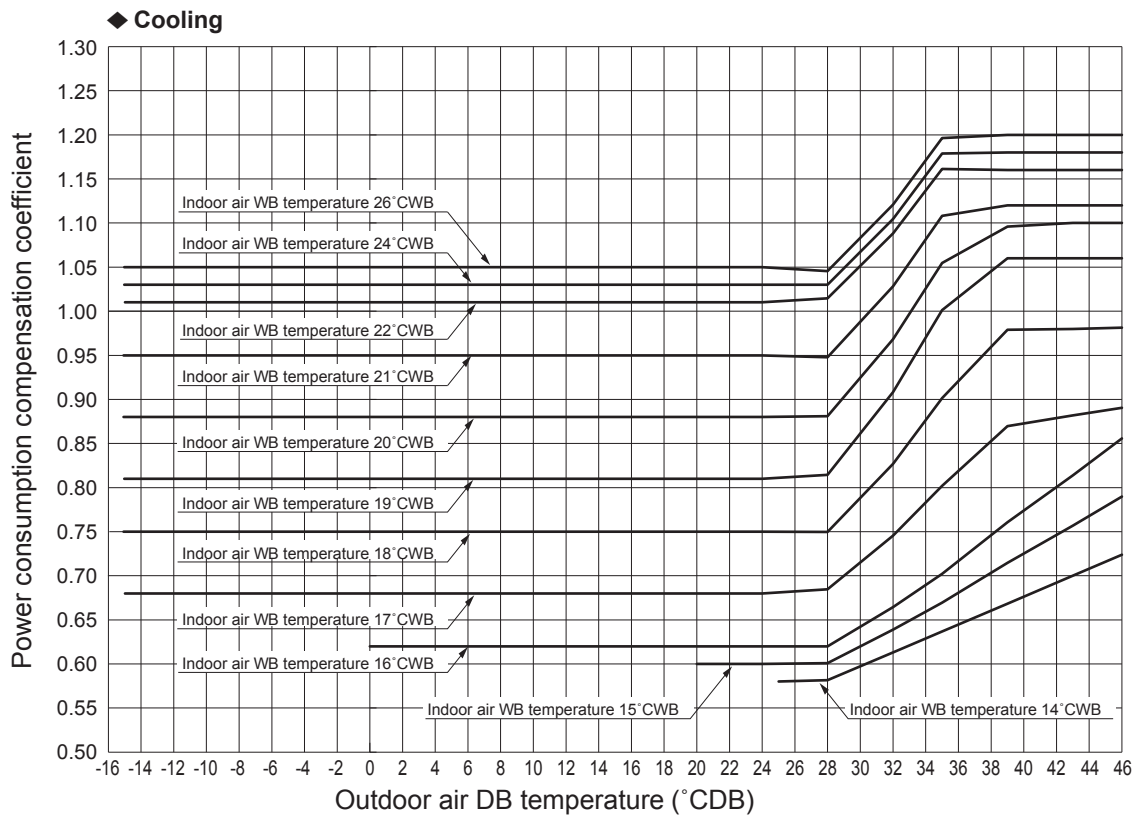

Note (1) The above-mentioned table shows a typical condition among conditions to occur via controlling an air-conditioning equipment.

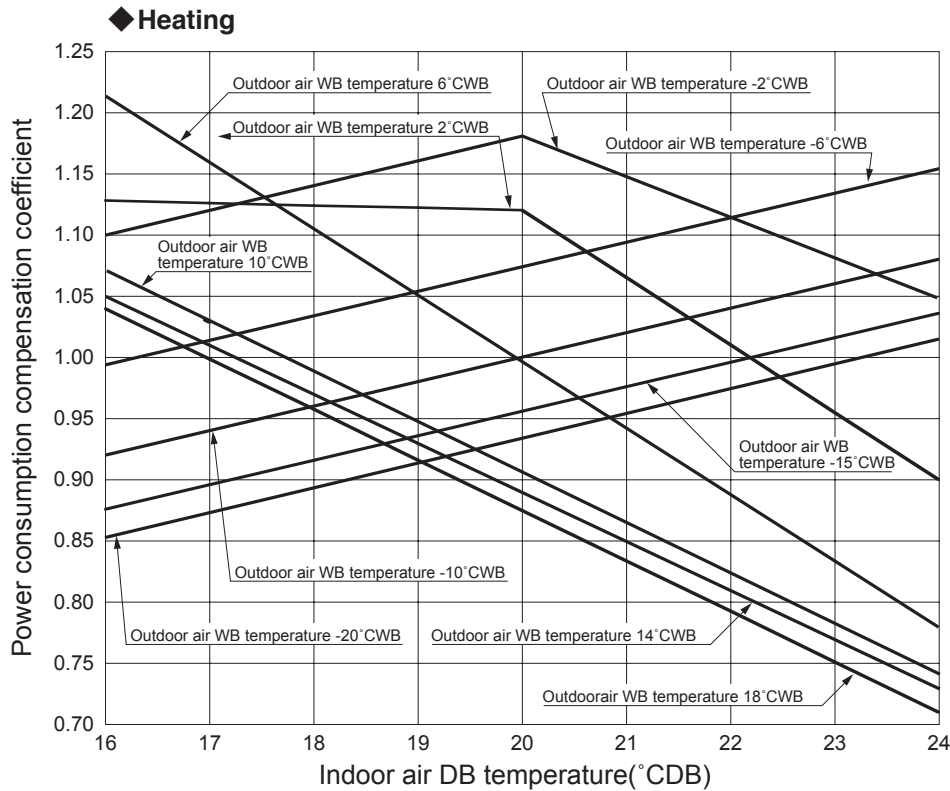

Note (1) The above-mentioned table shows a typical condition among conditions to occur via controlling an air-conditioning equipment.

(b) Correction of cooling and heating capacity in relation to one way length of refrigerant piping.

(Note) This table is for reference only. If the refrigerant piping one way equivalent after the first branch is extended longer than 40 m, it could drop further by about 10% in the worst case.

1) Cooling

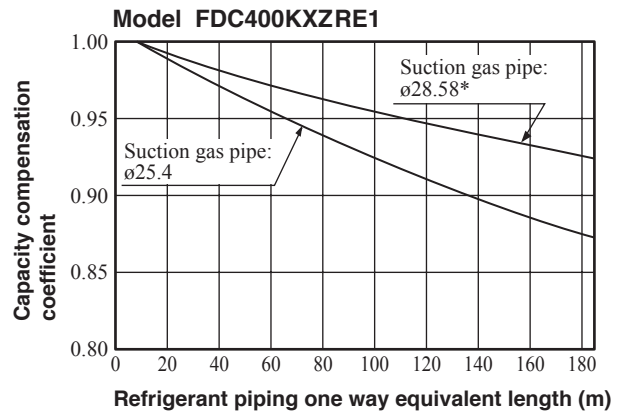
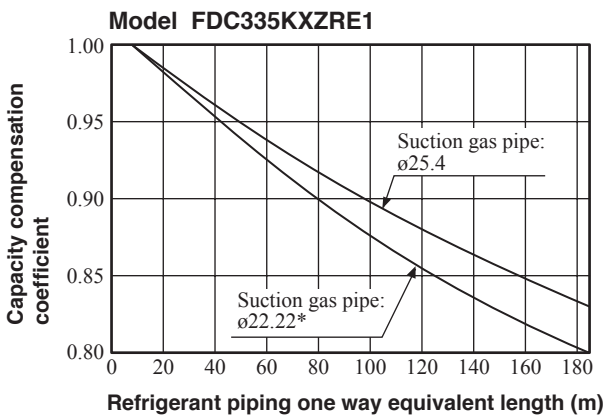
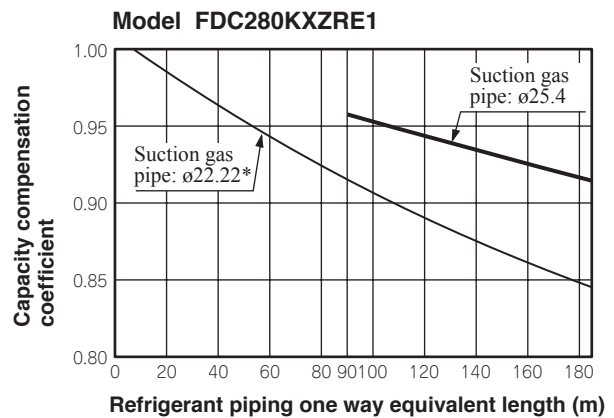
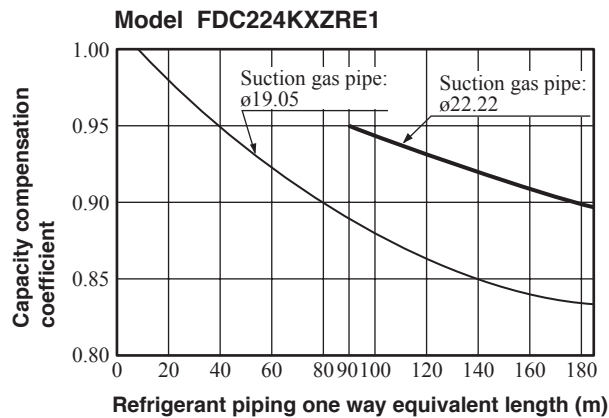

Note (1) Parts with the * mark show the piping size in case used in Europe.

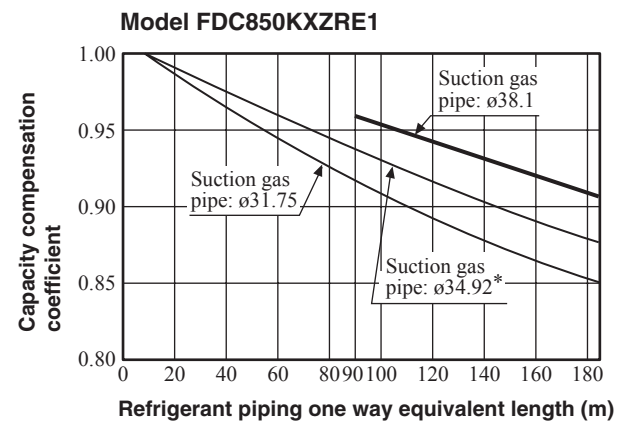
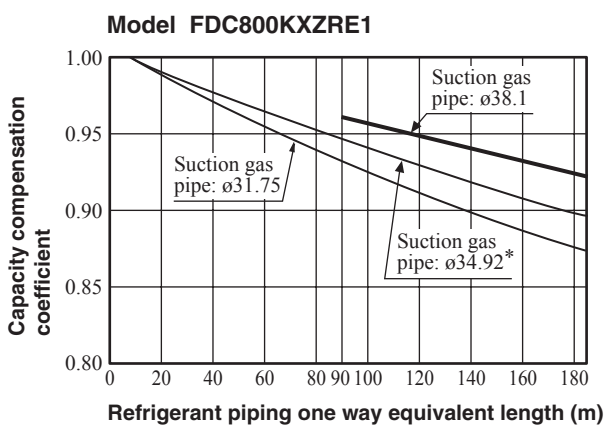
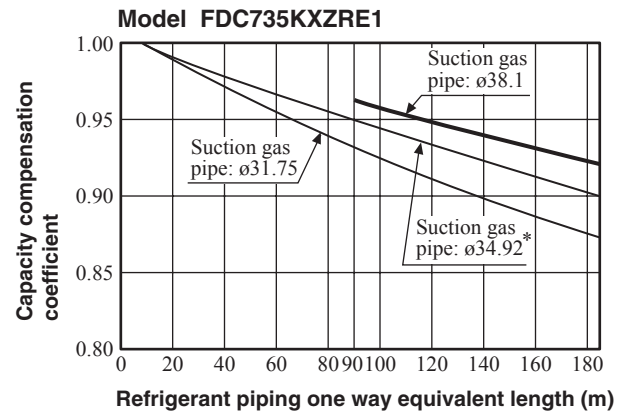
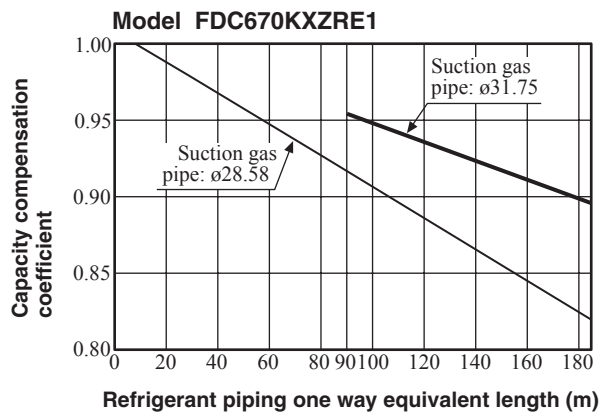
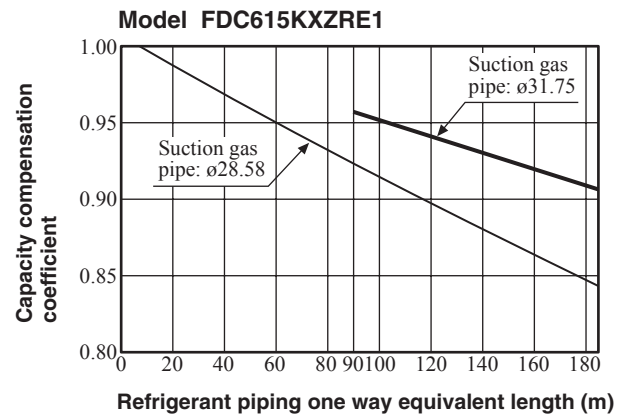
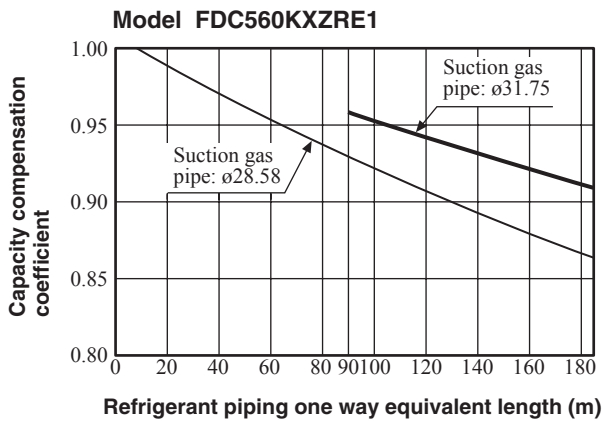
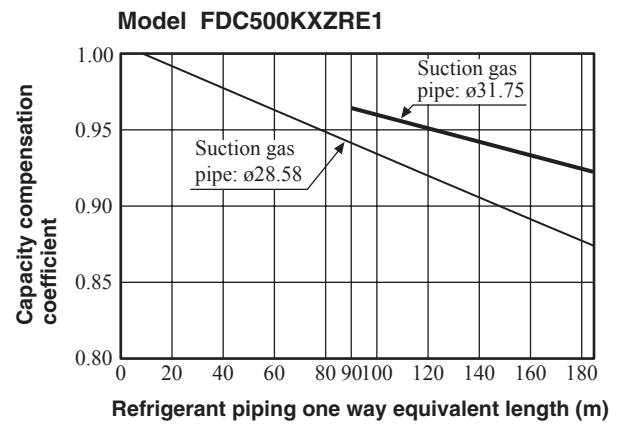
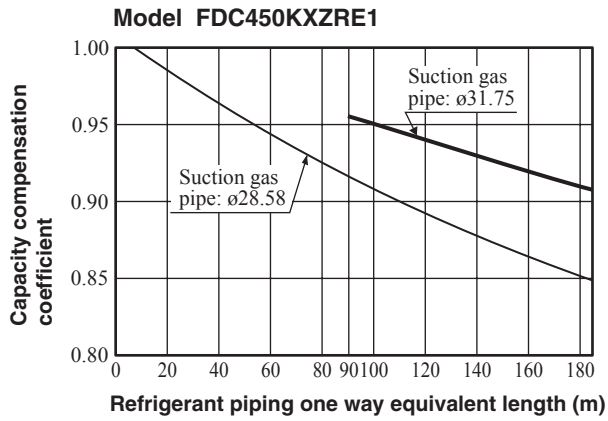

Note (1) Parts with the * mark show the piping size in case used in Europe.

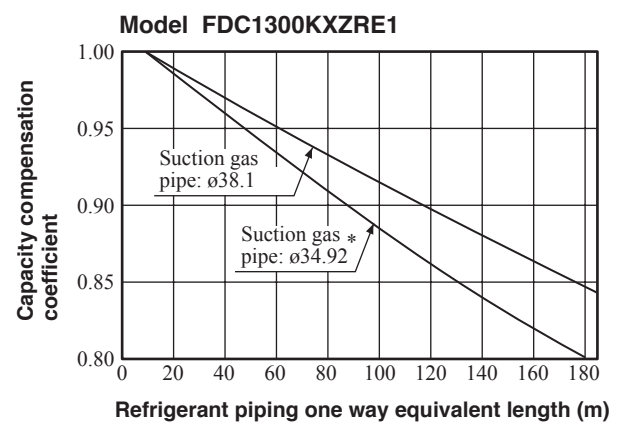
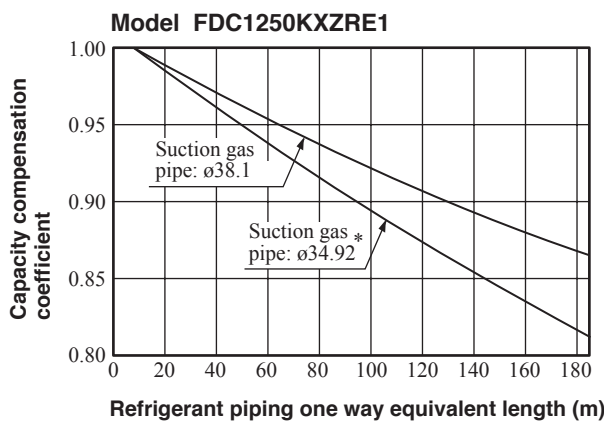
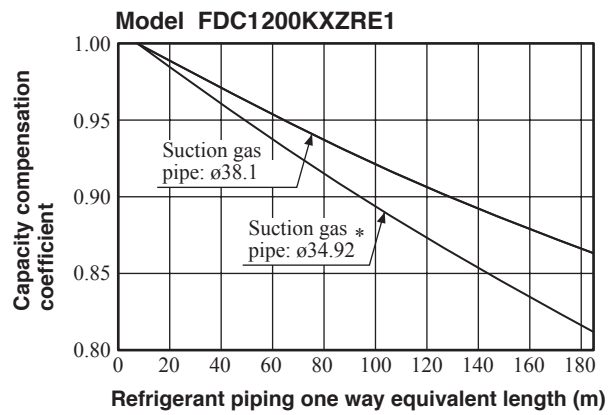
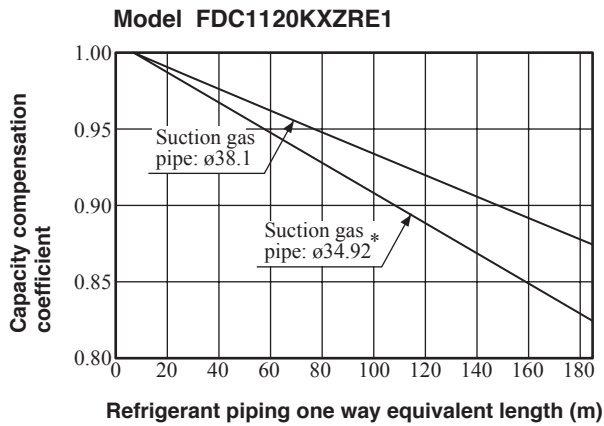
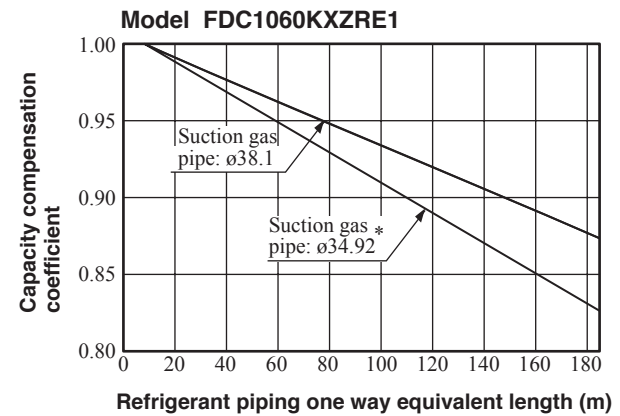
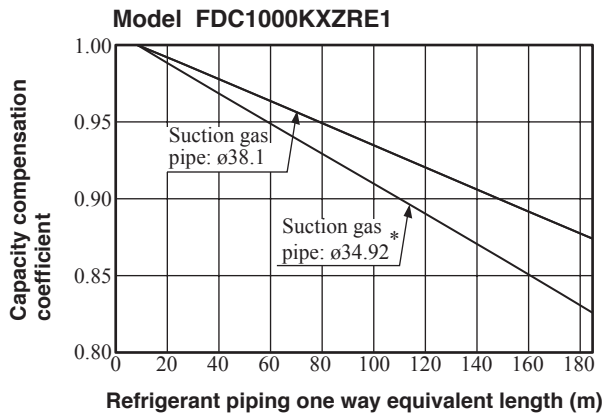
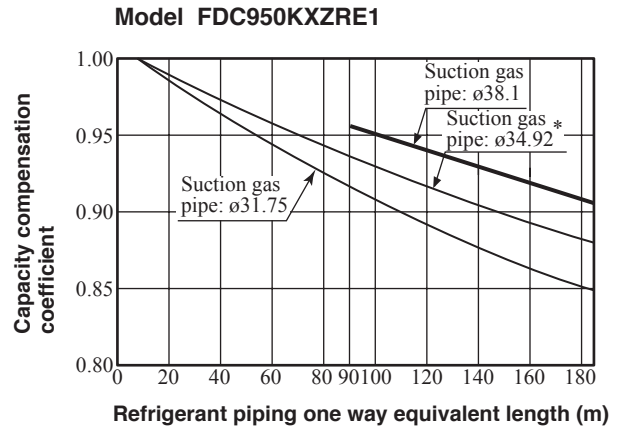
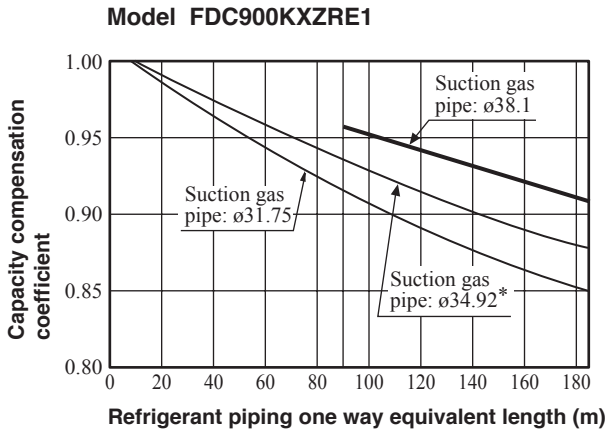

Note (1) Parts with the * mark show the piping size in case used in Europe.

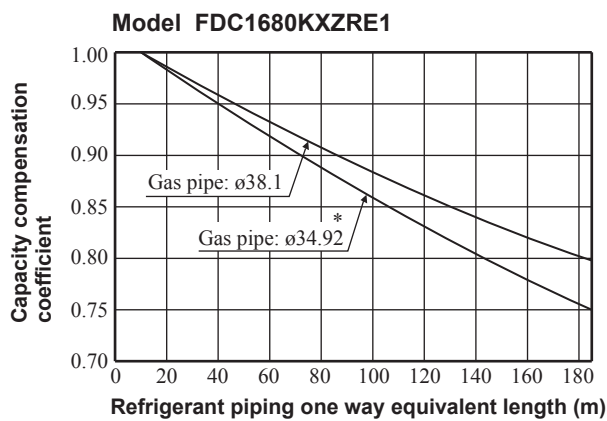
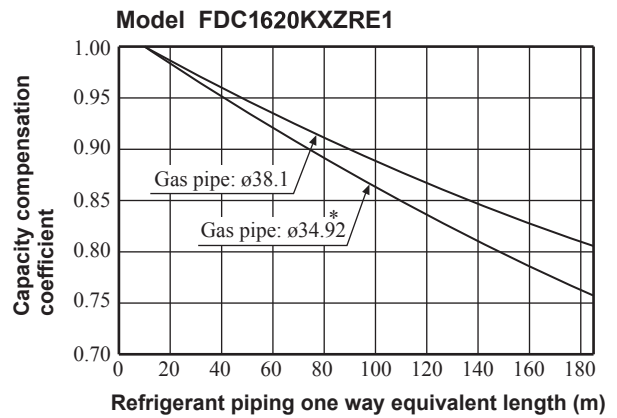
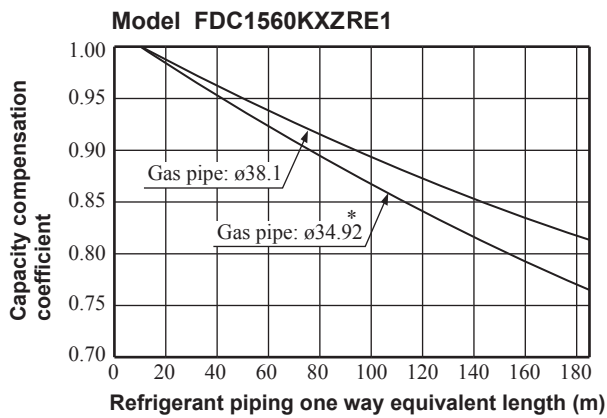
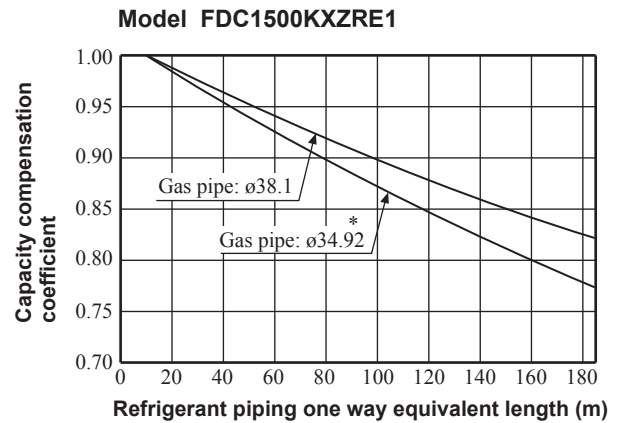
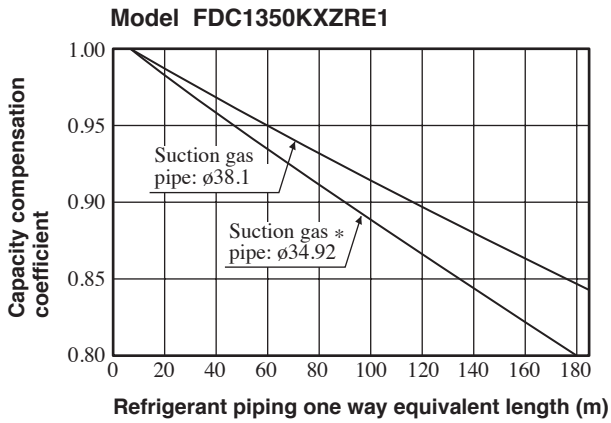

Note (1) Parts with the * mark show the piping size in case used in Europe.

2) Heating (Common)

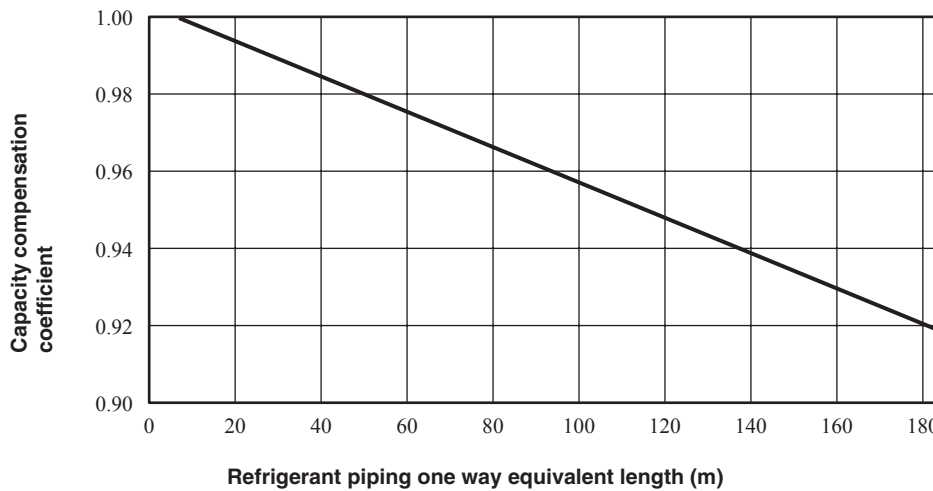

Note (1) Equivalent piping length can be obtained by calculating as follows.

$$\text{Equivalent piping length} = \text{Real gas piping length} + \text{Number of bends in gas piping} \times \text{Equivalent piping length of bends.}$$

Equivalent length of each joint

Unit : m/one part

Gas piping size	φ9.52	φ12.7	φ15.88	φ19.05	φ22.22	φ25.4	φ28.58	φ31.8	φ34.92	φ38.1
Joint (90°elbow)	0.15	0.20	0.25	0.30	0.35	0.40	0.45	0.55	0.60	0.65

- (c) When the outdoor unit is located at a lower height than the indoor unit in cooling operation and when the outdoor unit is located at a higher height than the indoor unit in heating operation, the following values should be subtracted from the values in the above table.

Height difference between the indoor unit and outdoor unit in the vertical height difference	5 m	10 m	15 m	20 m	25 m	30 m
Adjustment coefficient	0.99	0.98	0.97	0.96	0.95	0.94

Height difference between the indoor unit and outdoor unit in the vertical height difference	35 m	40 m	45 m	50 m
Adjustment coefficient	0.93	0.92	0.91	0.90

- (d) Correction of heating capacity in relation to the frost on the outdoor unit heat exchanger

Air inlet temperature of outdoor unit in °C WB	-20	-15	-13	-11	-9	-7	-5	-3	-1	1	3	5 or more
Adjustment coefficient	0.96	0.96	0.96	0.95	0.94	0.93	0.91	0.88	0.86	0.87	0.92	1

The correction factors will change drastically according to weather conditions. So necessary adjustment should be made empirically according to the weather data of the particular area.

- (e) The capacity compensation coefficient and power consumption compensation coefficient vary according to the total capacity of concurrently operating indoor units, as shown next page.

Model FDC224KXZRE1

◆ Capability compensation coefficient

Cooling

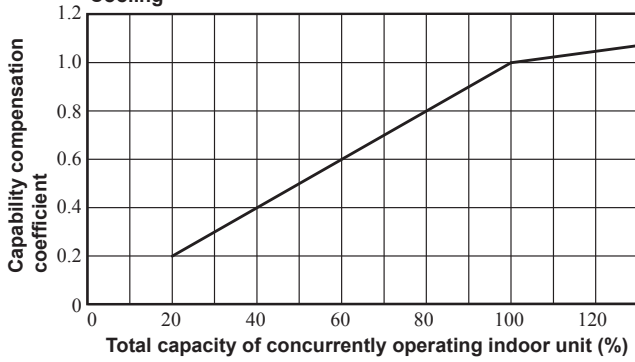

Heating

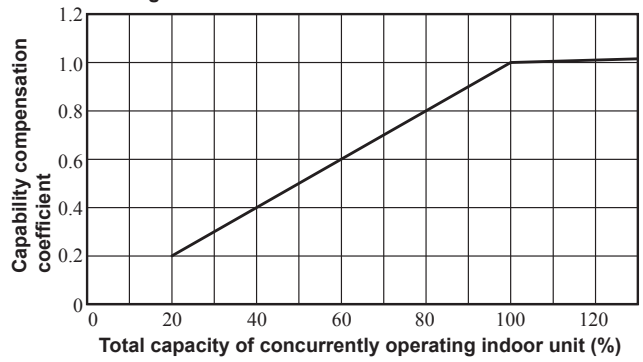

◆ Power consumption compensation coefficient

Cooling

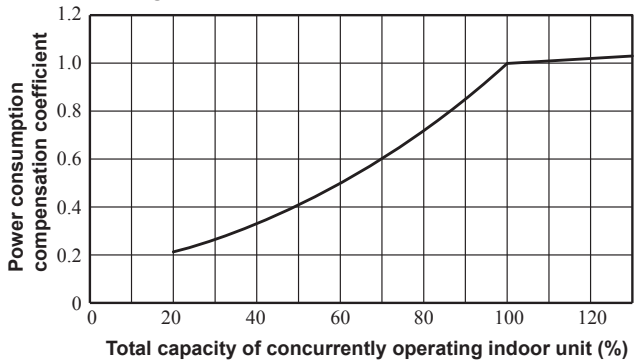

Heating

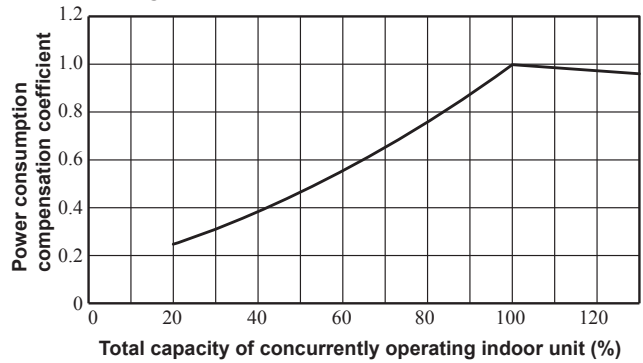

Model FDC280KXZRE1

◆ Capability compensation coefficient

Cooling

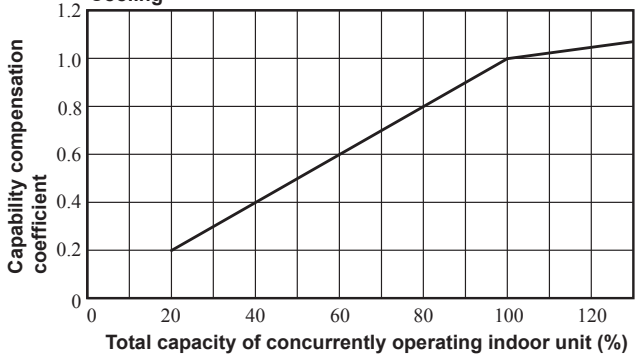

Heating

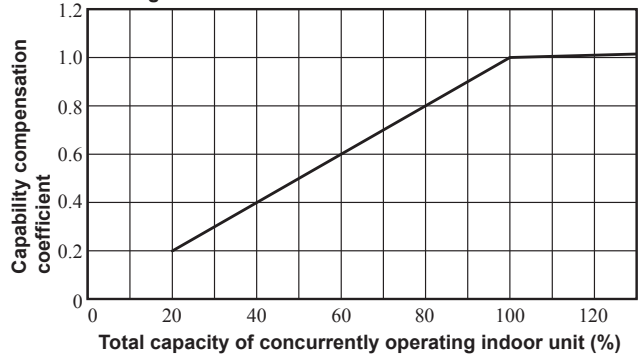

◆ Power consumption compensation coefficient

Cooling

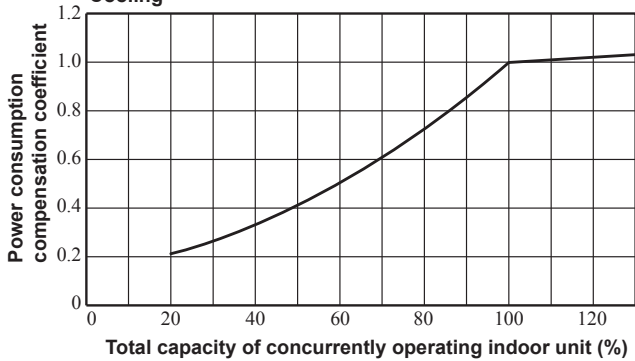

Heating

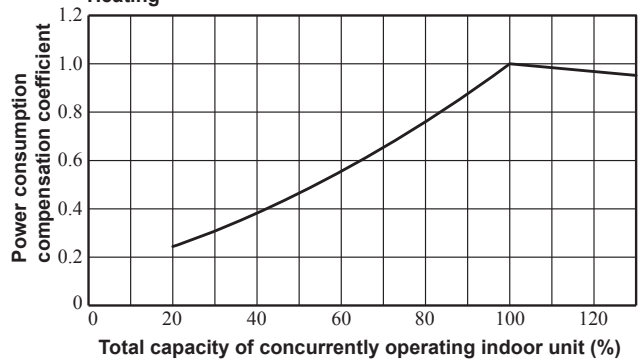

Model FDC335KXZRE1

◆ **Capability compensation coefficient**

Cooling

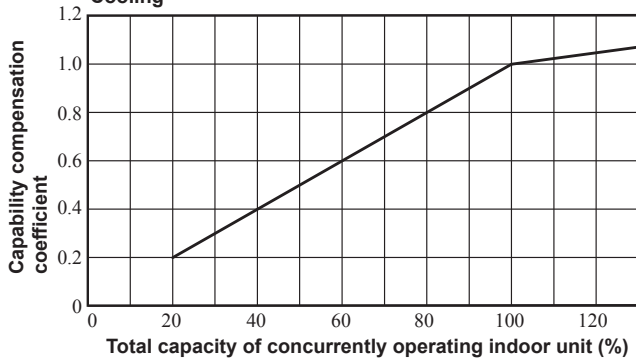

Heating

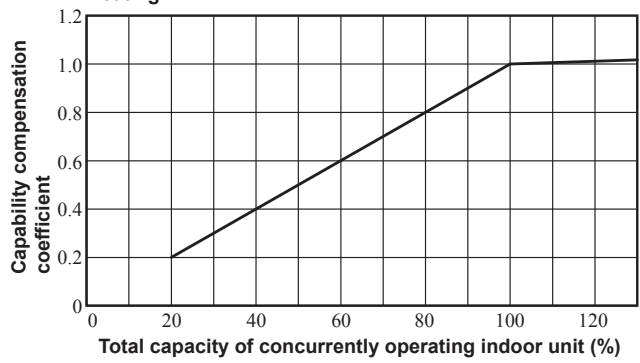

◆ **Power consumption compensation coefficient**

Cooling

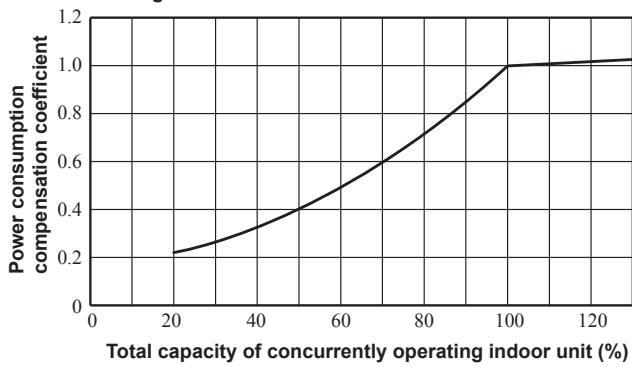

Heating

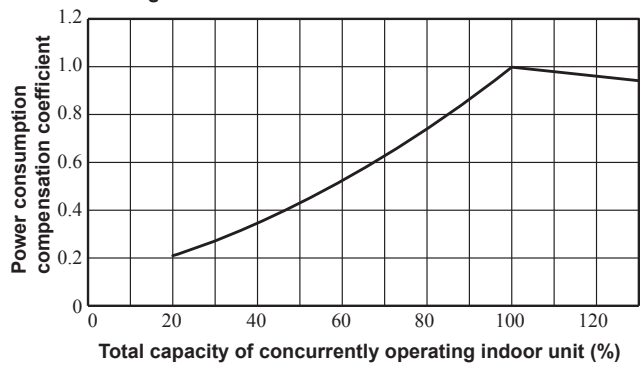

Model FDC400KXZRE1

◆ **Capability compensation coefficient**

Cooling

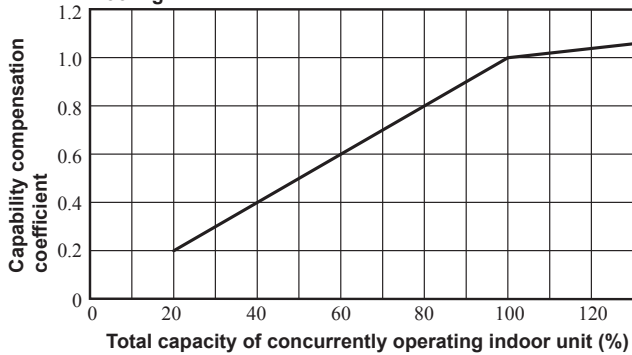

Heating

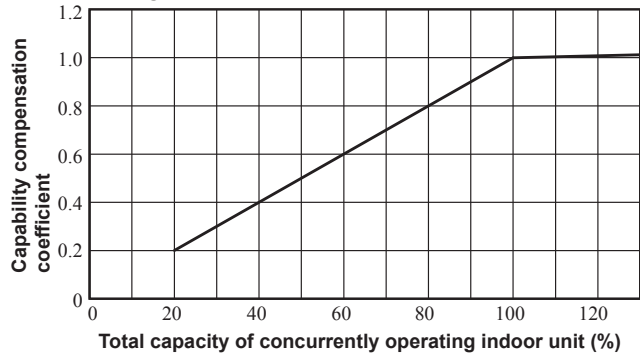

◆ **Power consumption compensation coefficient**

Cooling

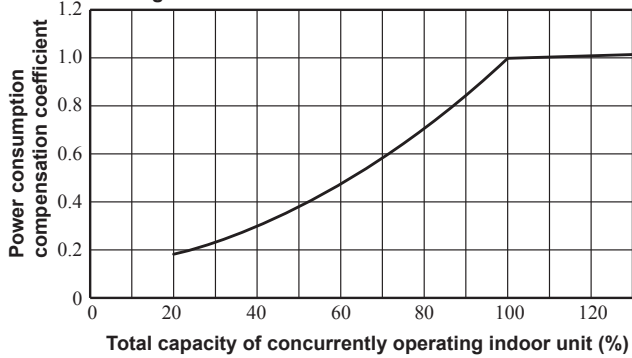

Heating

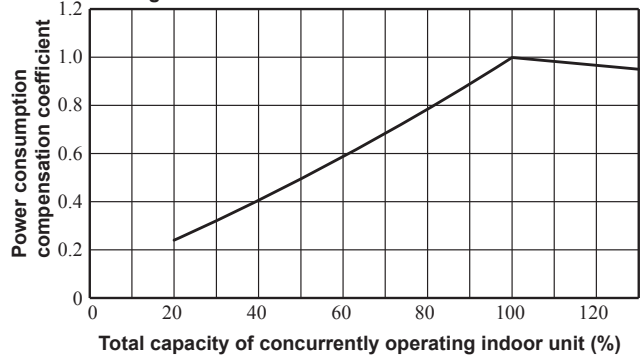

Model FDC450KXZRE1

◆ **Capability compensation coefficient**

Cooling

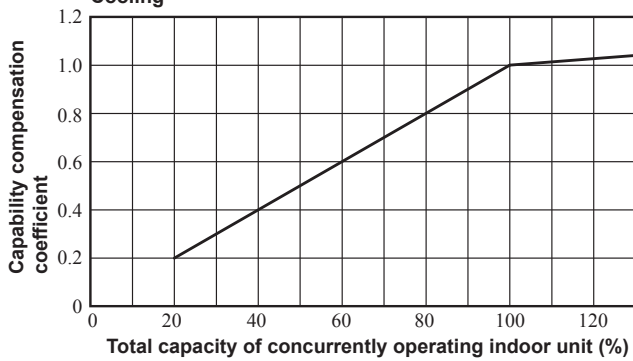

Heating

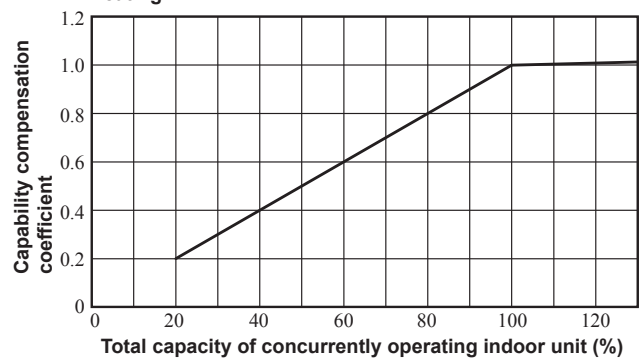

◆ **Power consumption compensation coefficient**

Cooling

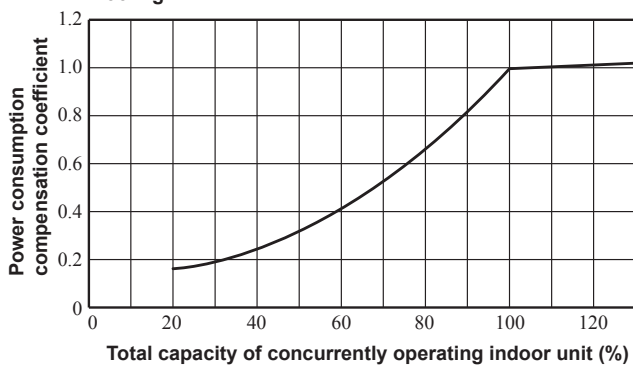

Heating

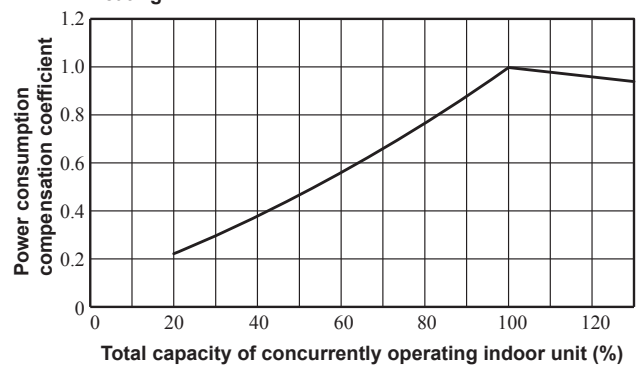

Model FDC475KXZRE1

◆ **Capability compensation coefficient**

Cooling

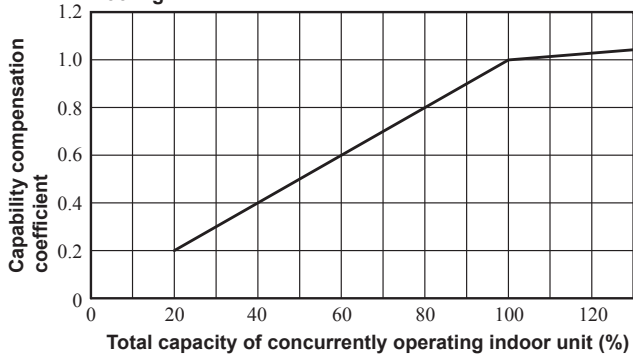

Heating

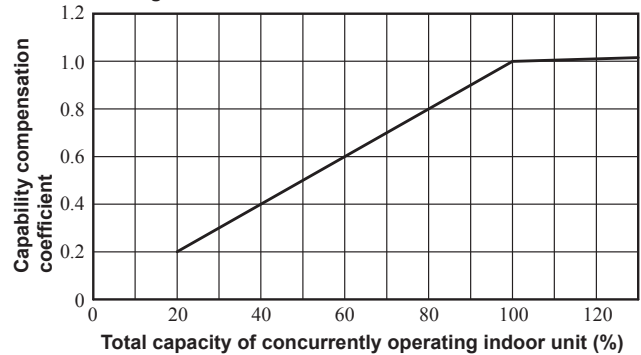

◆ **Power consumption compensation coefficient**

Cooling

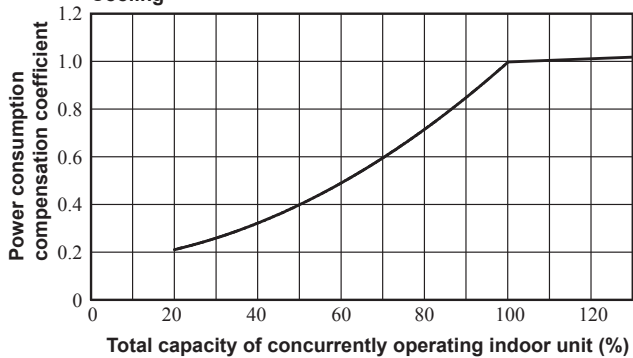

Heating

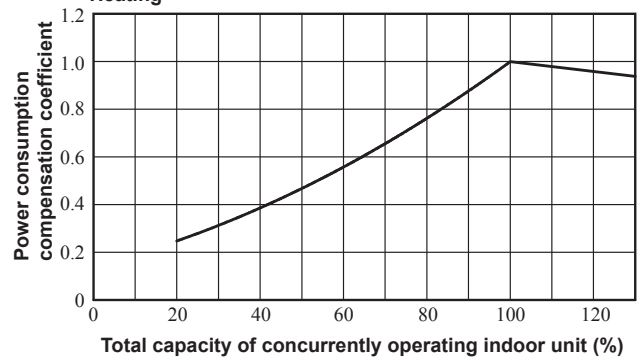

Model FDC500KXZRE1

◆ **Capability compensation coefficient**
Cooling

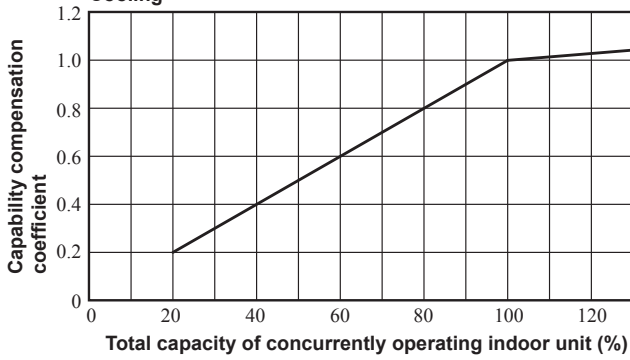

Heating

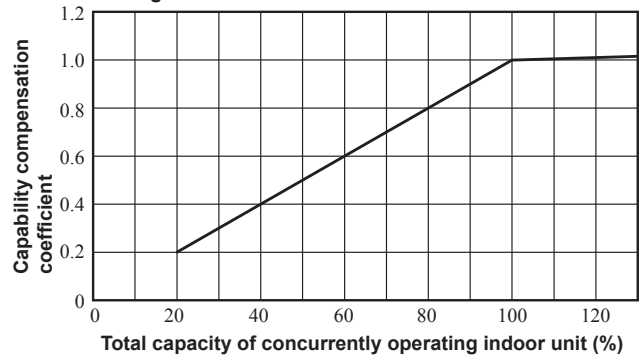

◆ **Power consumption compensation coefficient**
Cooling

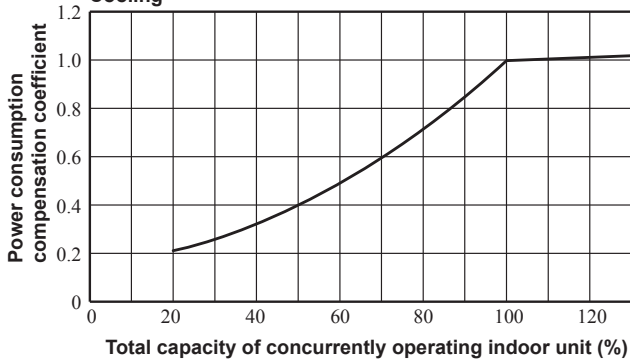

Heating

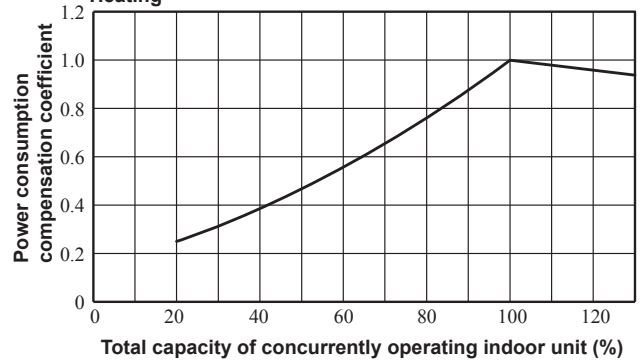

Model FDC560KXZRE1

◆ **Capability compensation coefficient**
Cooling

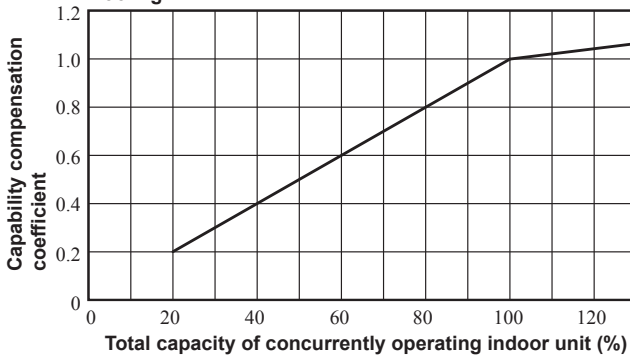

Heating

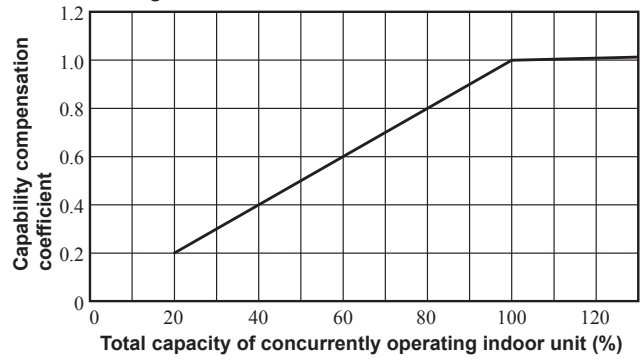

◆ **Power consumption compensation coefficient**
Cooling

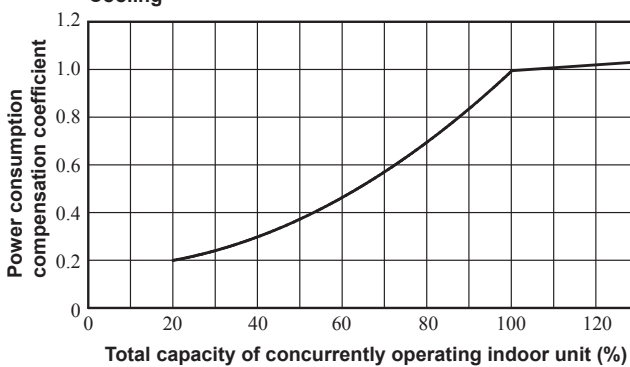

Heating

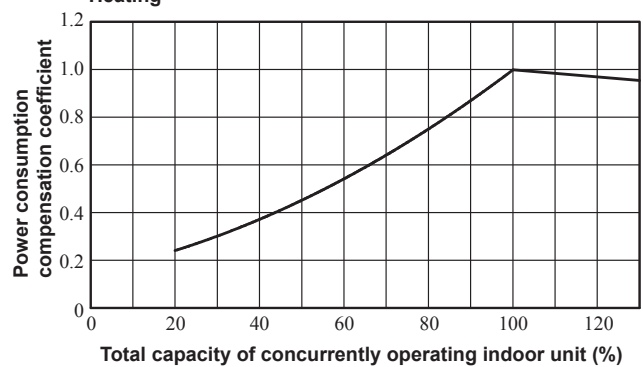

Model FDC615KXZRE1

◆ **Capability compensation coefficient**

Cooling

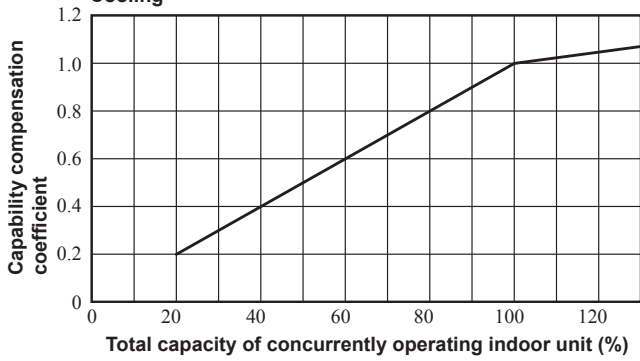

Heating

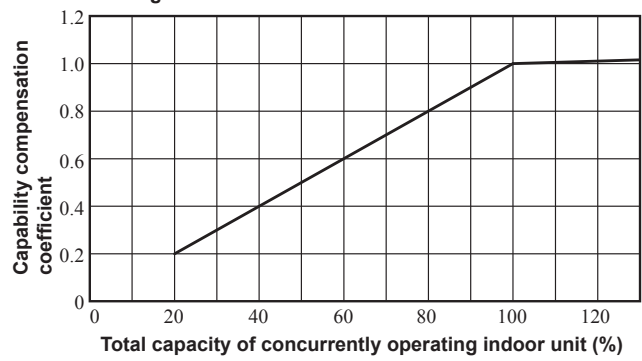

◆ **Power consumption compensation coefficient**

Cooling

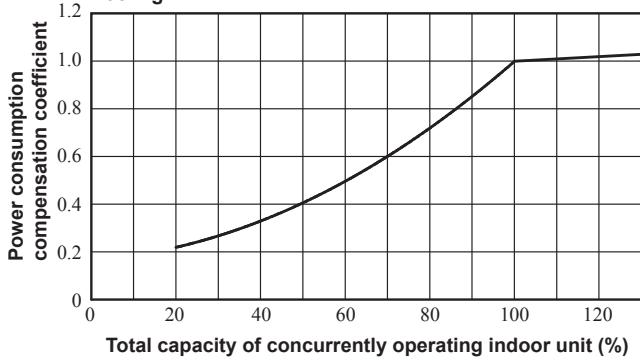

Heating

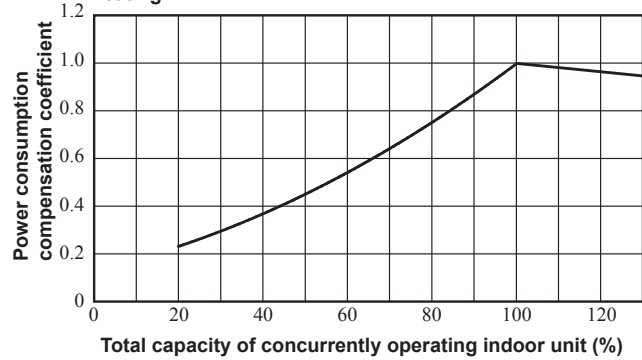

Model FDC670KXZRE1

◆ **Capability compensation coefficient**

Cooling

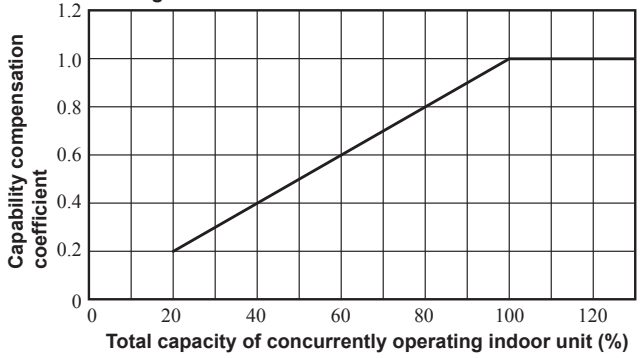

Heating

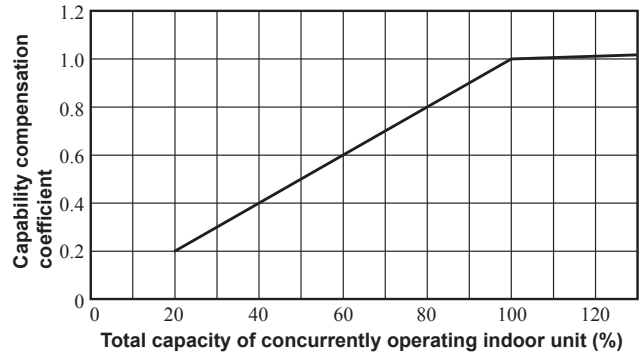

◆ **Power consumption compensation coefficient**

Cooling

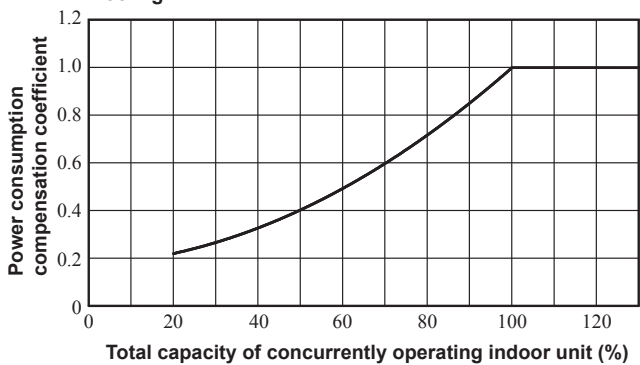

Heating

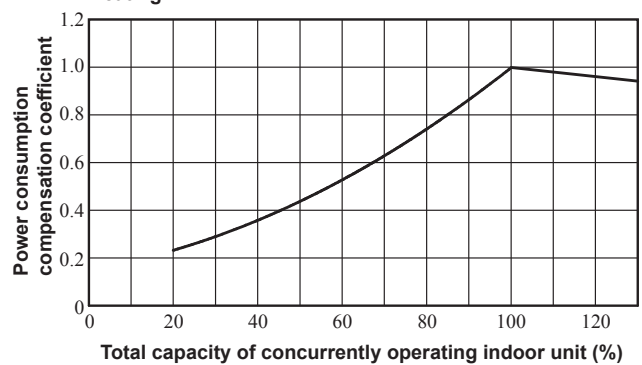

Model FDC735KXZRE1

◆ **Capability compensation coefficient**

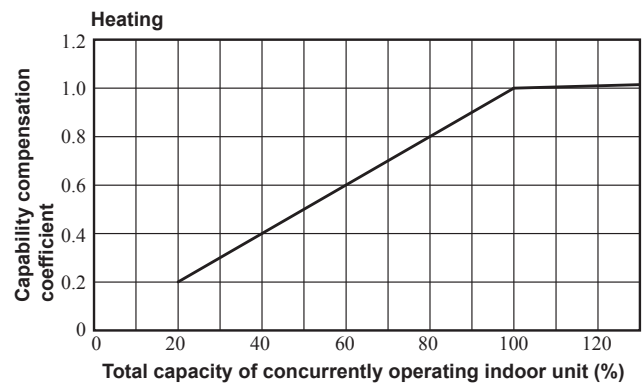
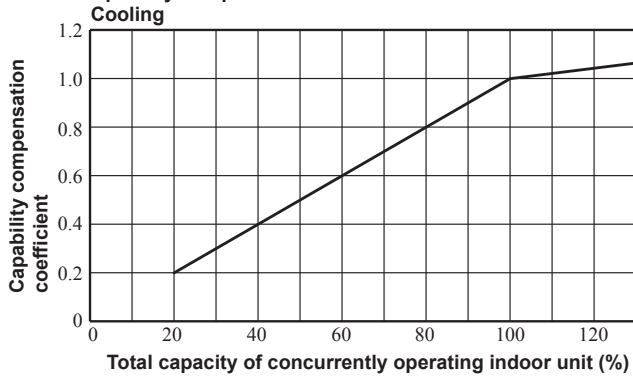

◆ **Power consumption compensation coefficient**

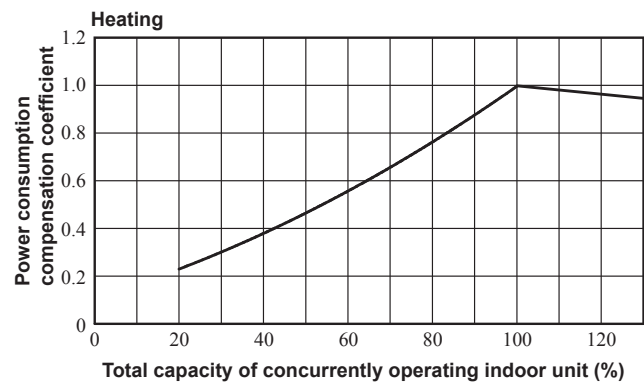
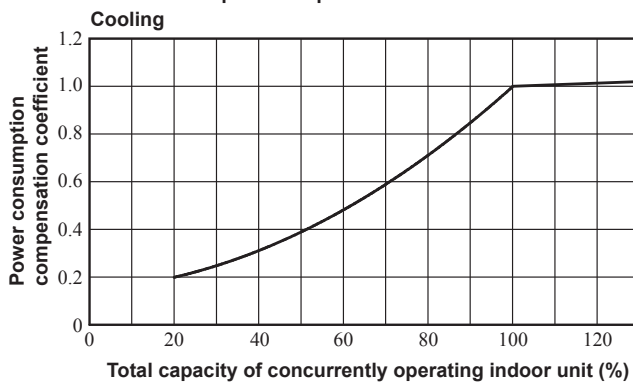

Model FDC800KXZRE1

◆ **Capability compensation coefficient**

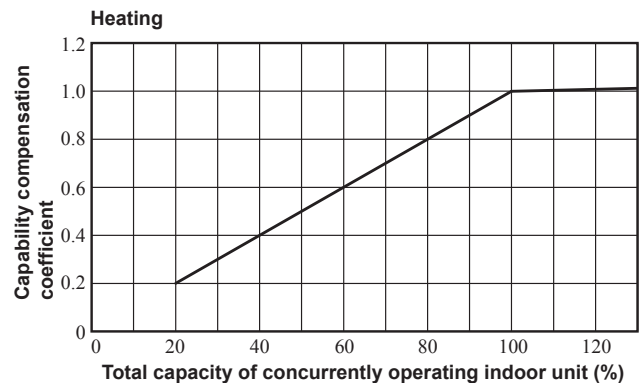
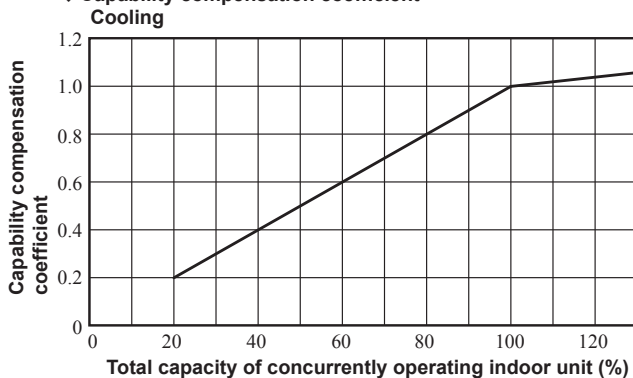

◆ **Power consumption compensation coefficient**

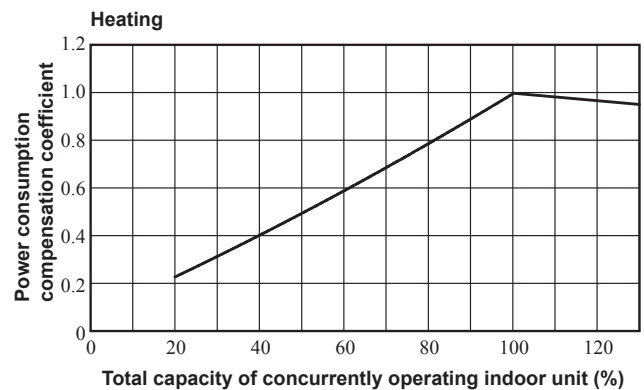
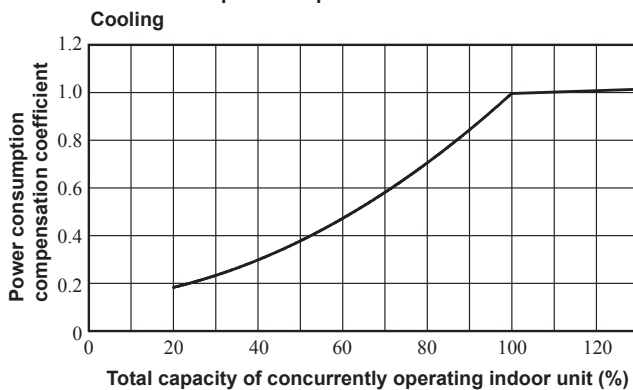

Model FDC850KXZRE1

◆ Capability compensation coefficient

Cooling

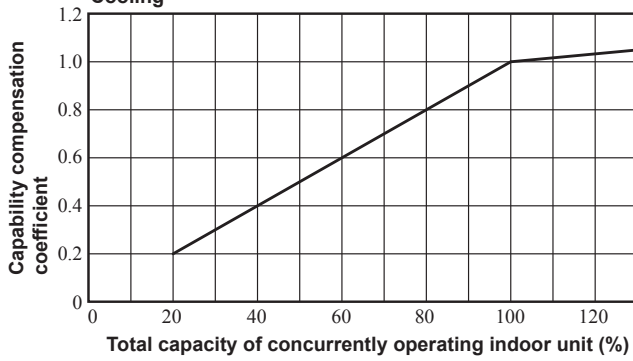

Heating

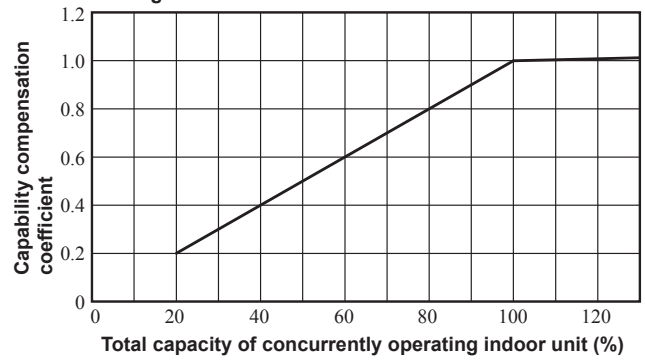

◆ Power consumption compensation coefficient

Cooling

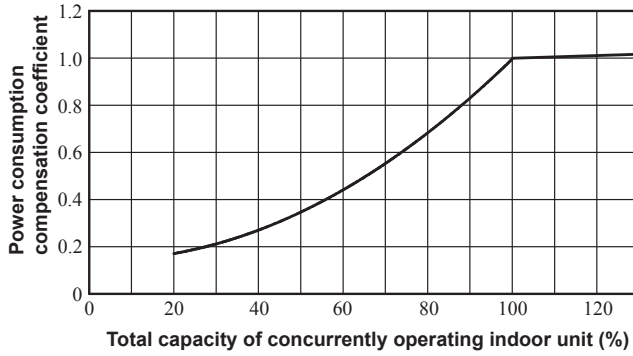

Heating

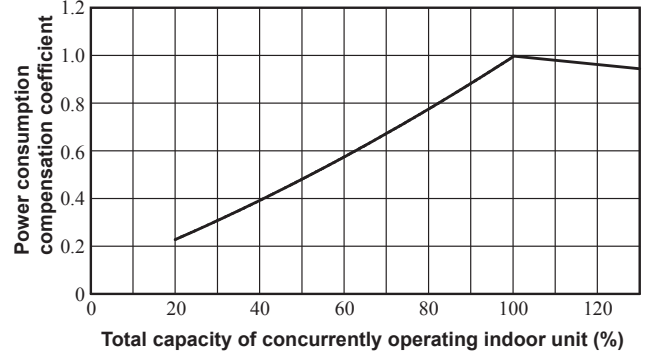

Model FDC900KXZRE1

◆ Capability compensation coefficient

Cooling

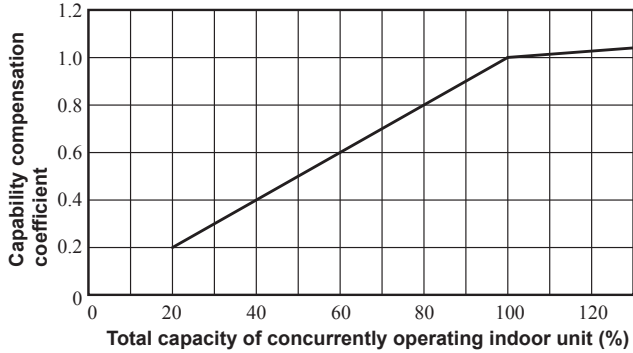

Heating

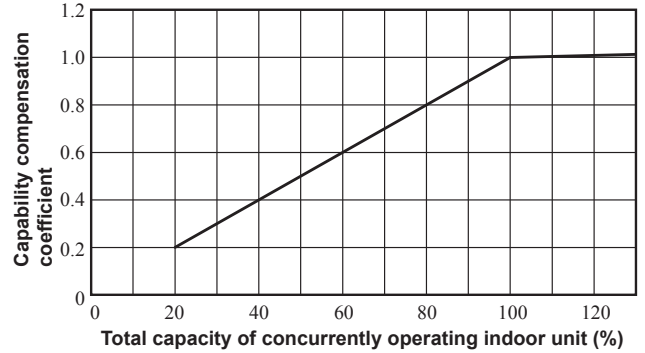

◆ Power consumption compensation coefficient

Cooling

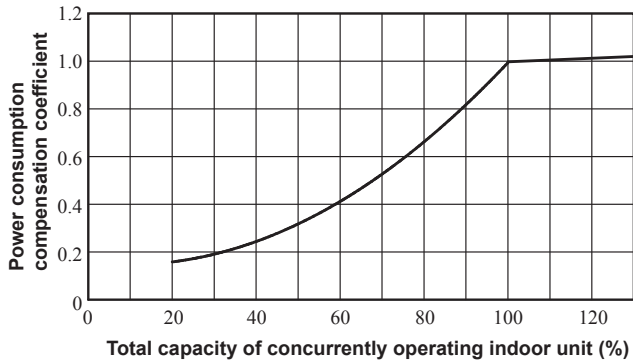

Heating

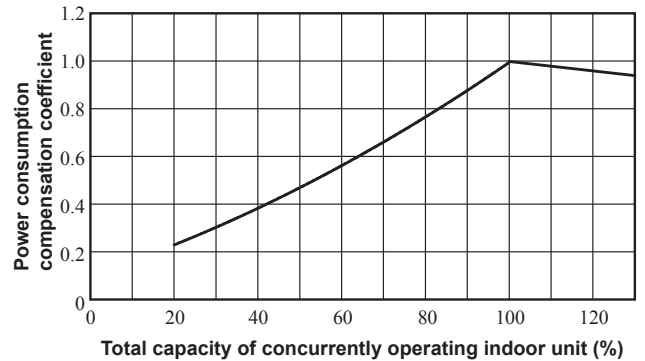

Model FDC950KXZRE1

◆ Capability compensation coefficient
Cooling

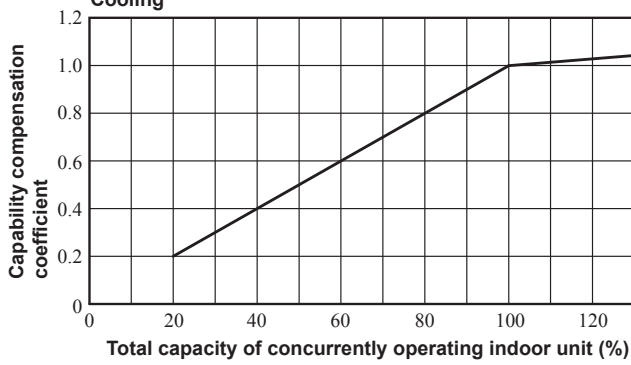

Heating

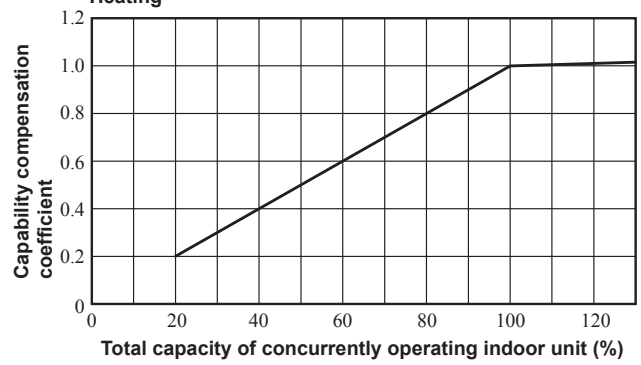

◆ Power consumption compensation coefficient

Cooling

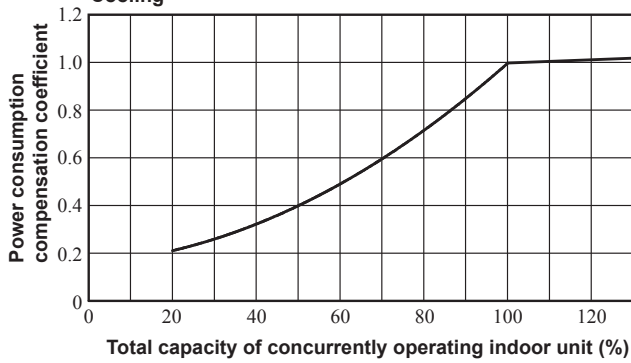

Heating

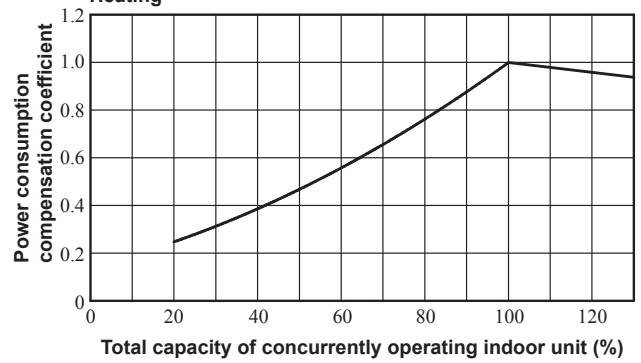

Model FDC1000KXZRE1

◆ Capability compensation coefficient
Cooling

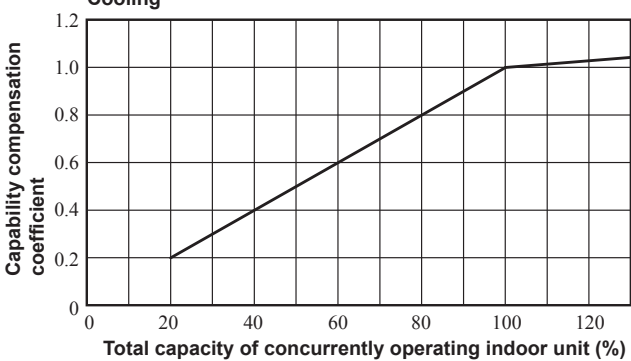

Heating

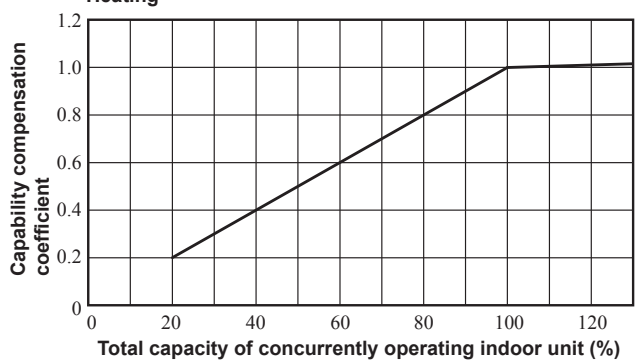

◆ Power consumption compensation coefficient

Cooling

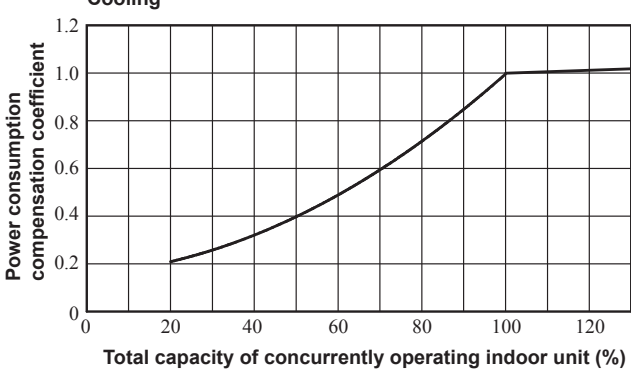

Heating

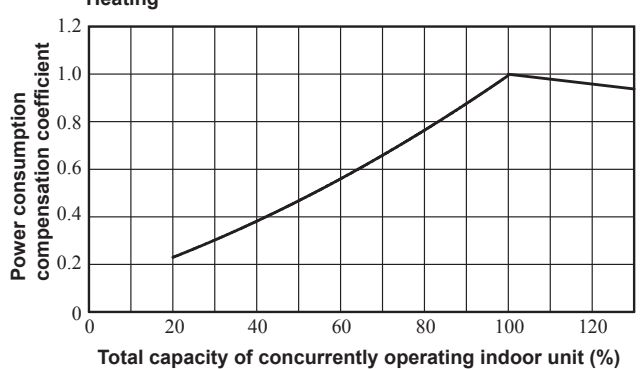

Model FDC1060KXZRE1

◆ Capability compensation coefficient
Cooling

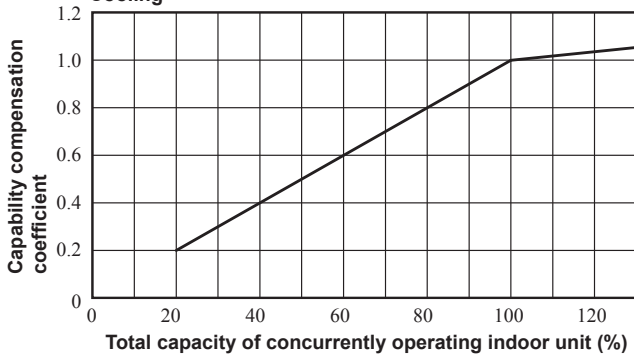

Heating

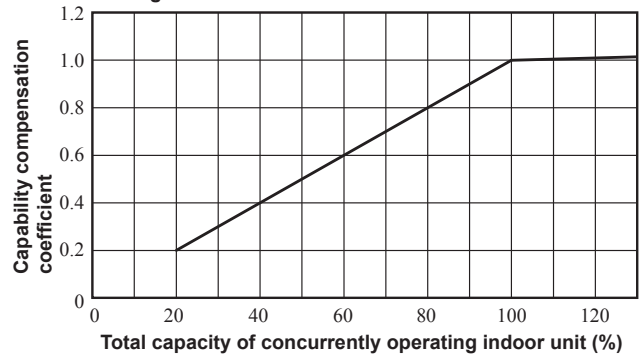

◆ Power consumption compensation coefficient
Cooling

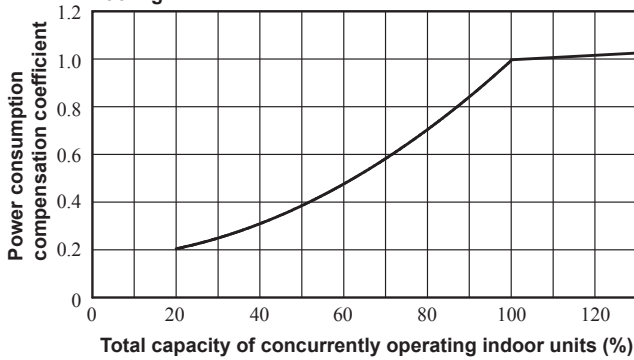

Heating

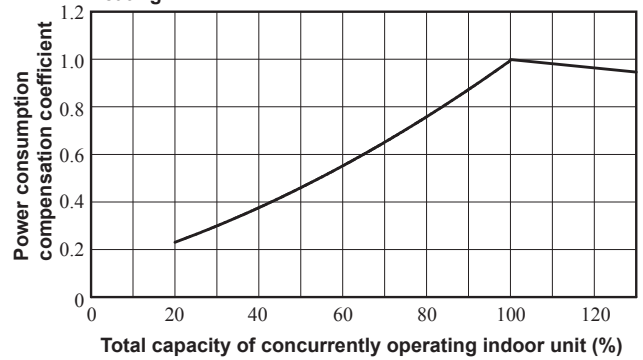

Model FDC1120KXZRE1

◆ Capability compensation coefficient
Cooling

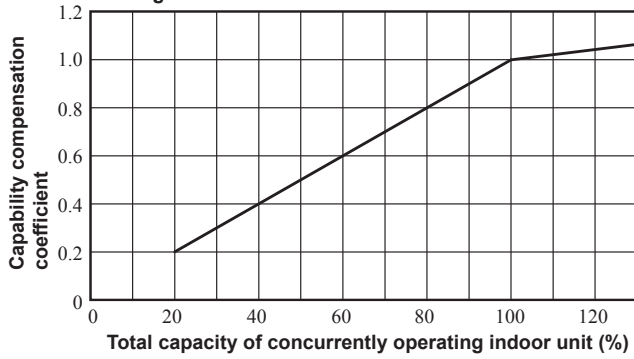

Heating

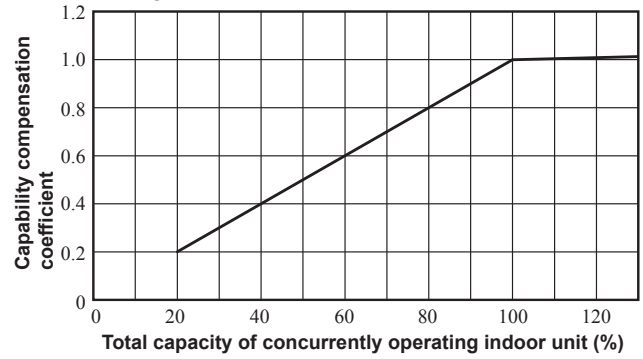

◆ Power consumption compensation coefficient
Cooling

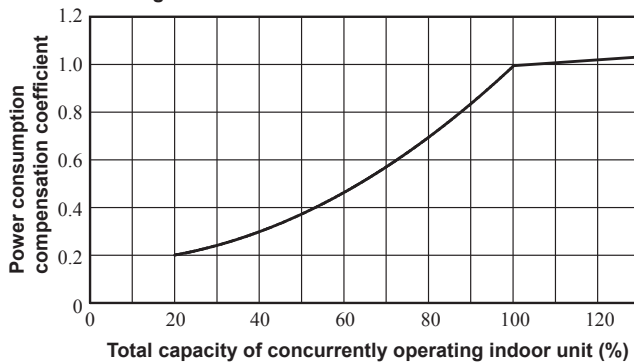

Heating

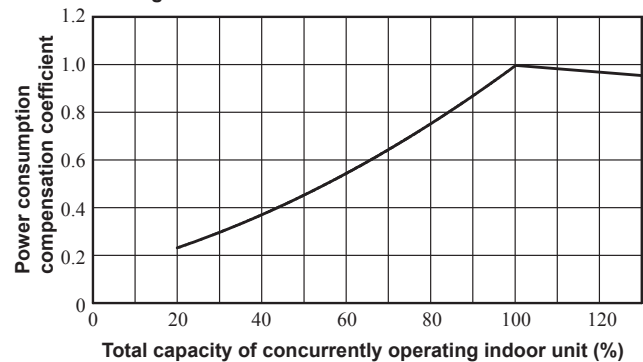

Model FDC1200KXZRE1

◆ Capability compensation coefficient

Cooling

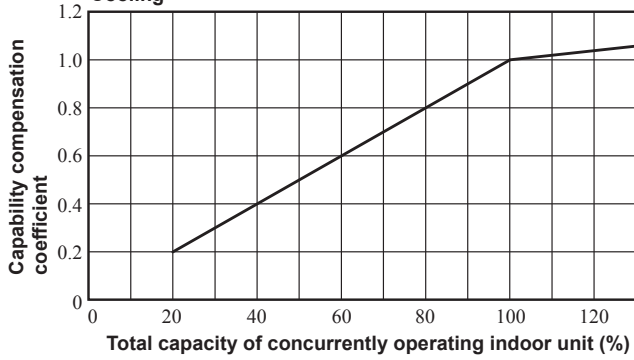

Heating

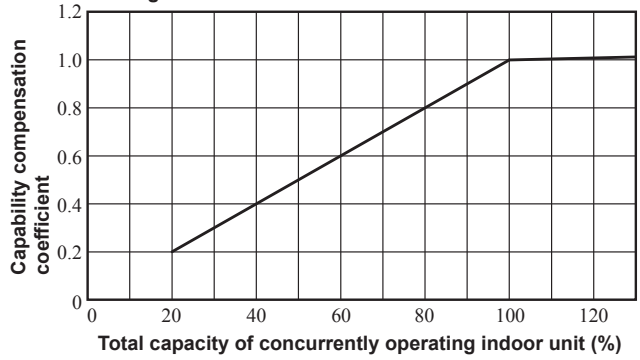

◆ Power consumption compensation coefficient

Cooling

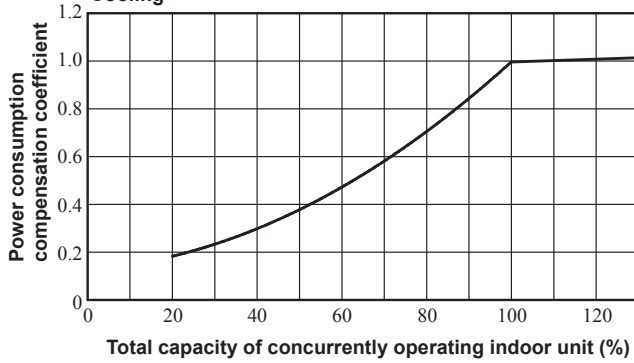

Heating

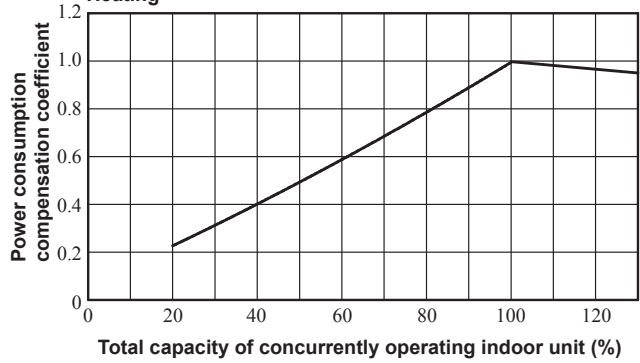

Model FDC1250KXZRE1

◆ Capability compensation coefficient

Cooling

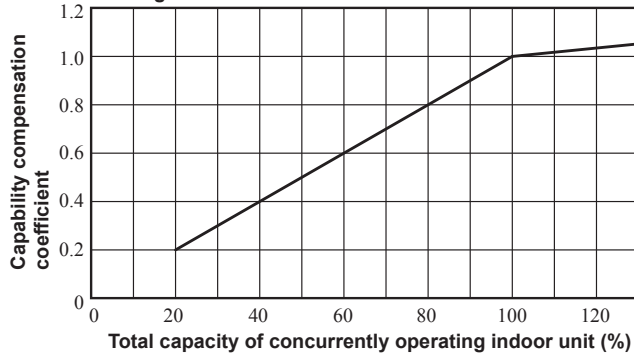

Heating

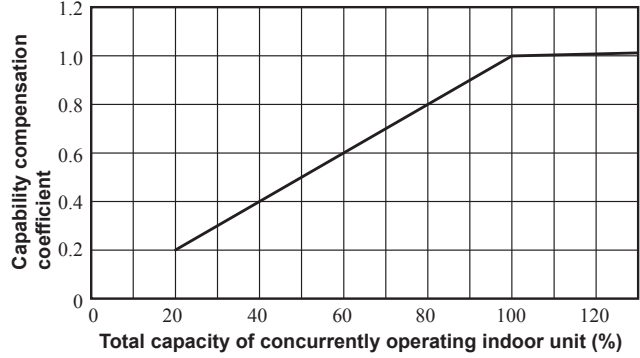

◆ Power consumption compensation coefficient

Cooling

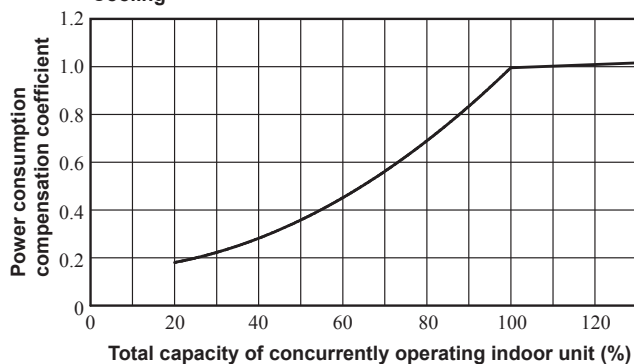

Heating

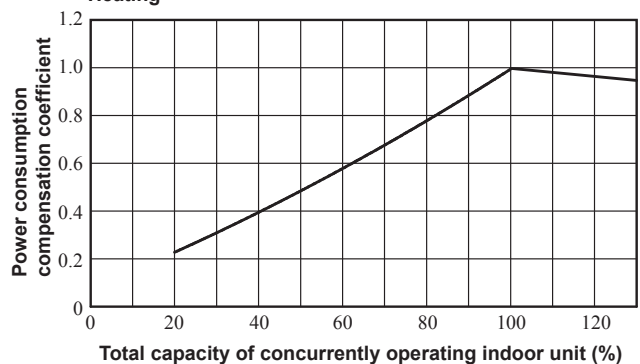

Model FDC1300KXZRE1

◆ **Capability compensation coefficient**

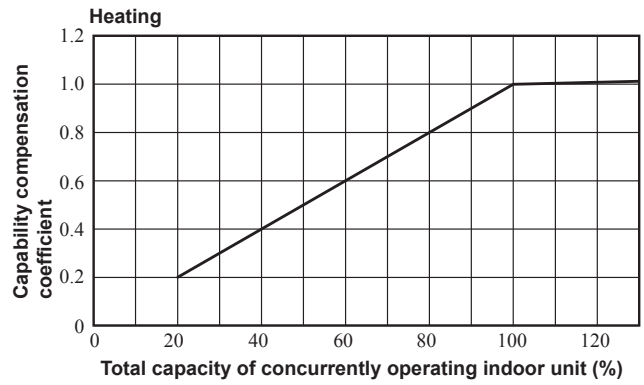
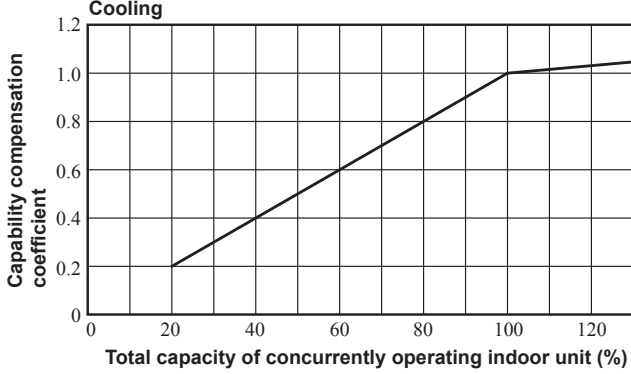

◆ **Power consumption compensation coefficient**

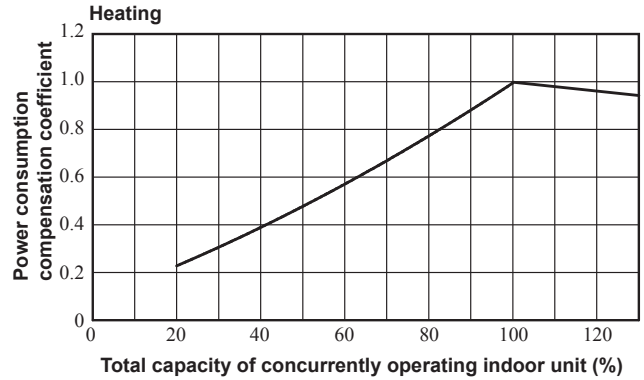
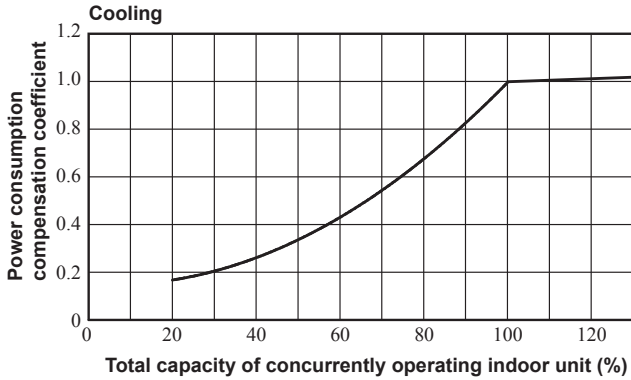

Model FDC1350KXZRE1

◆ **Capability compensation coefficient**

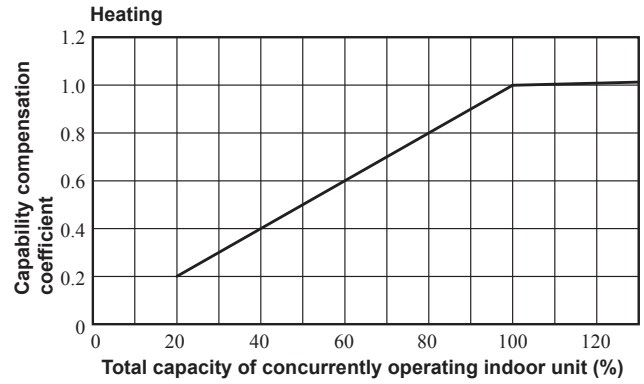
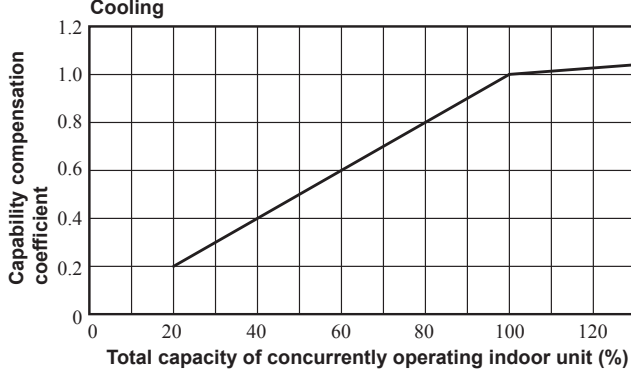

◆ **Power consumption compensation coefficient**

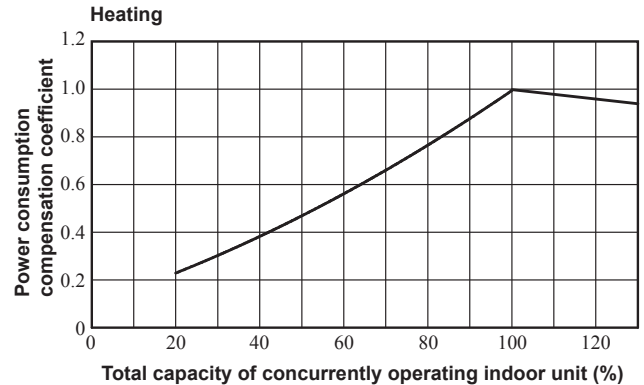
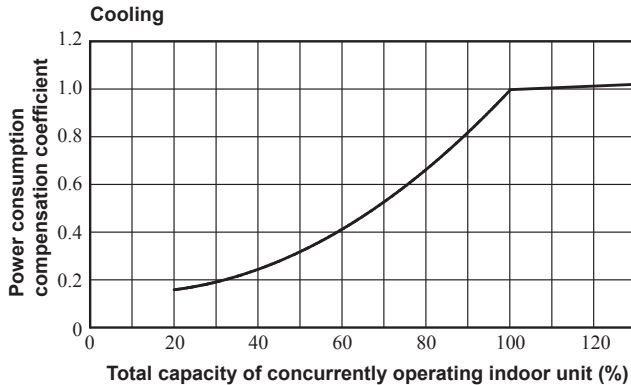

Model FDC1425KXZRE1

◆ Capability compensation coefficient

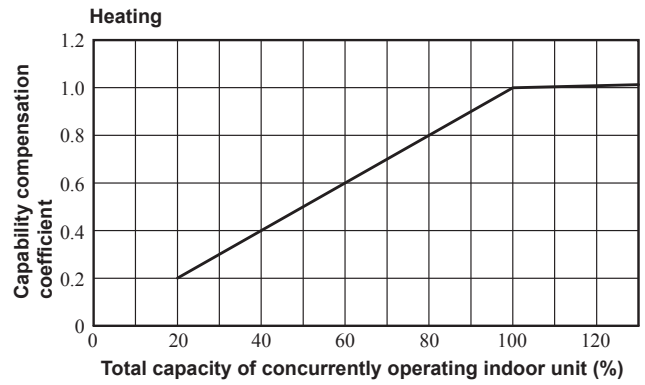
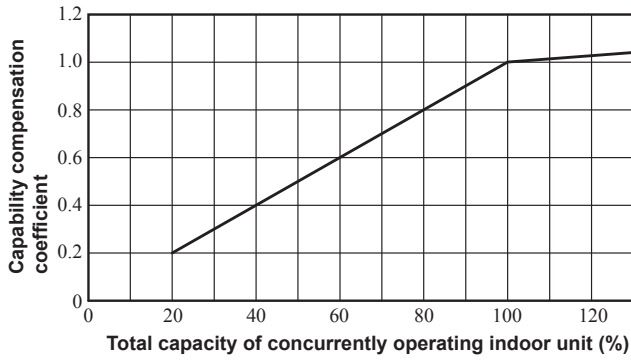

◆ Power consumption compensation coefficient

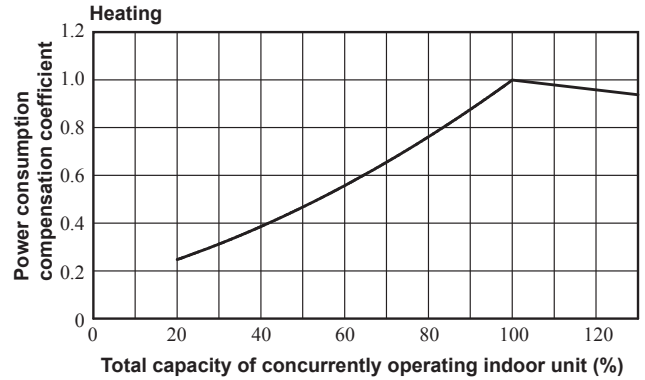
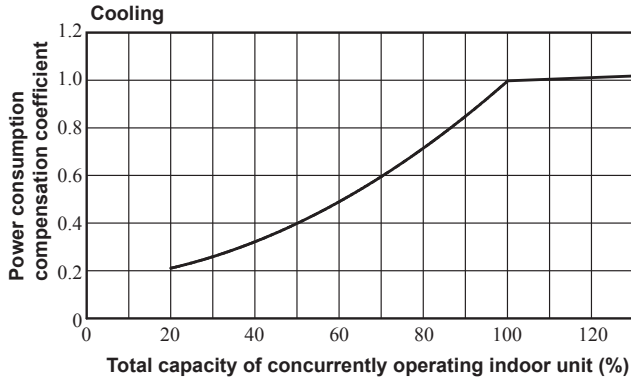

Model FDC1450KXZRE1

◆ Capability compensation coefficient

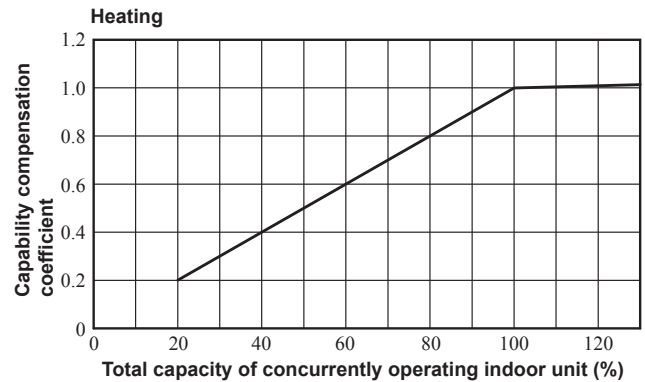
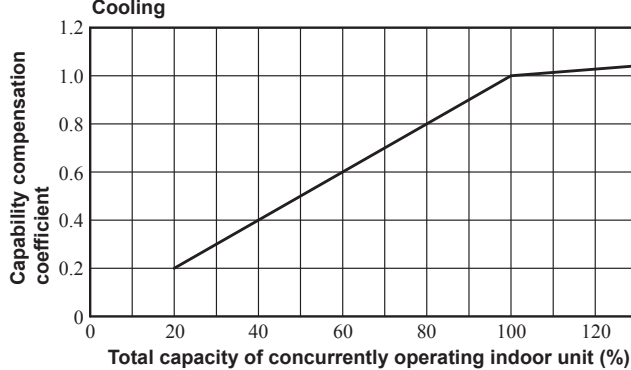

◆ Power consumption compensation coefficient

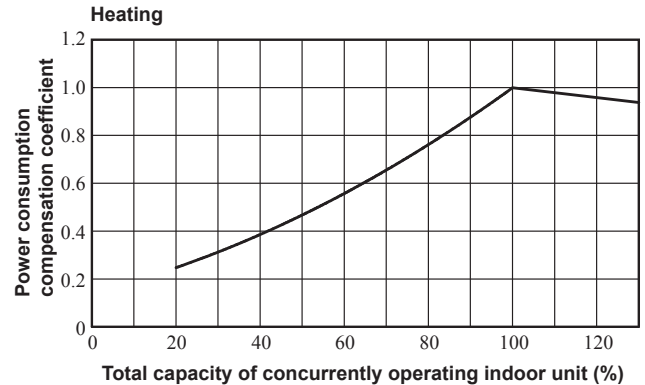
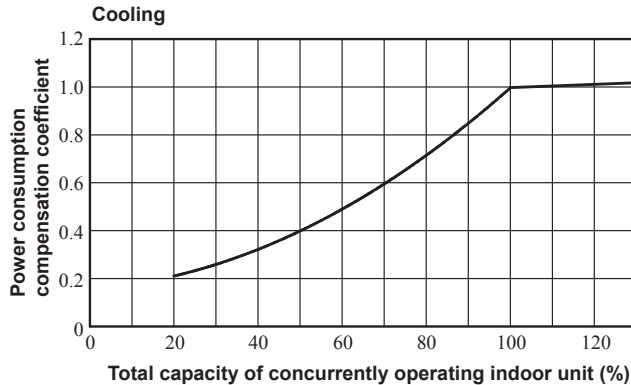

Model FDC1500KXZRE1

◆ **Capability compensation coefficient**

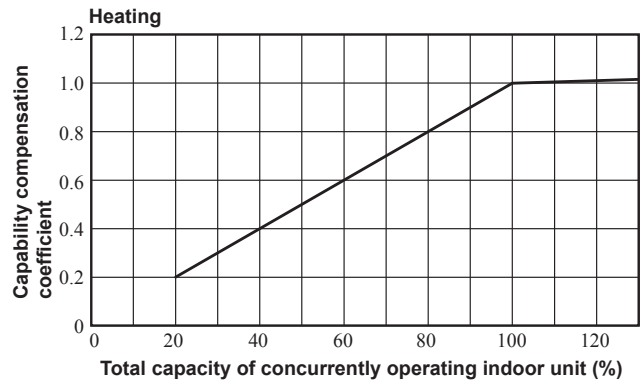
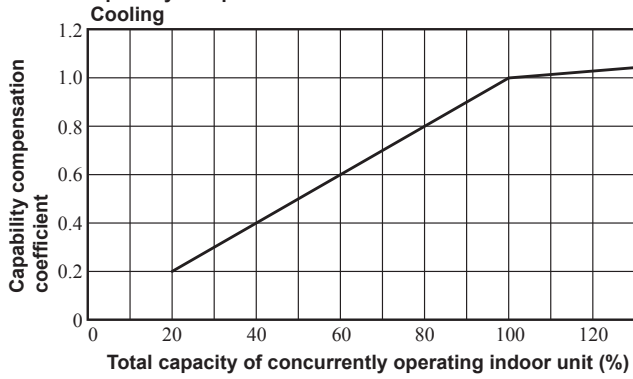

◆ **Power consumption compensation coefficient**

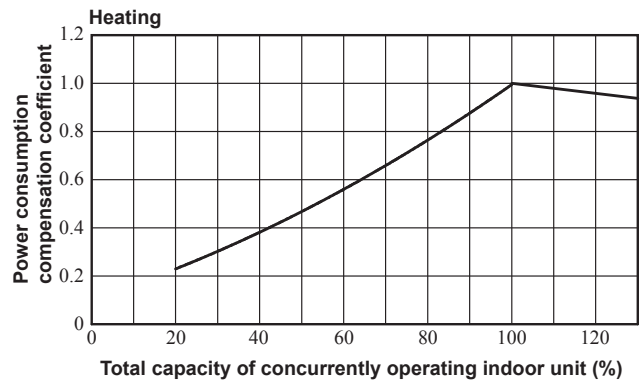
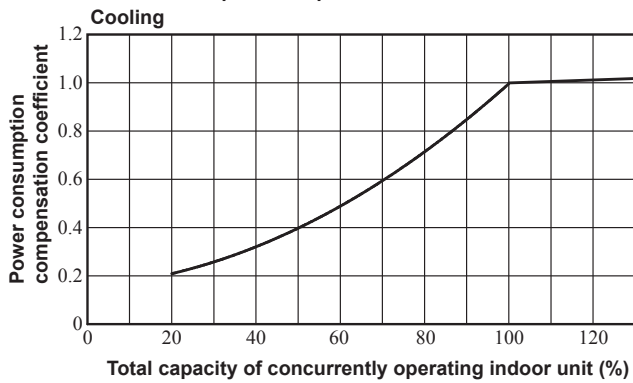

Model FDC1560KXZRE1

◆ **Capability compensation coefficient**

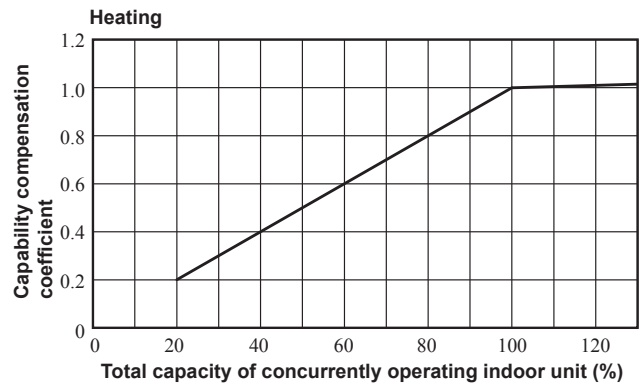
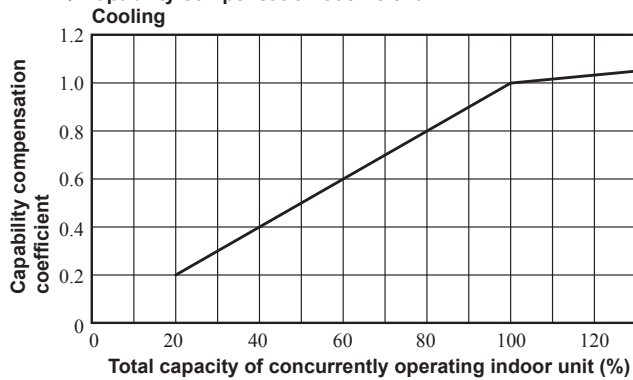

◆ **Power consumption compensation coefficient**

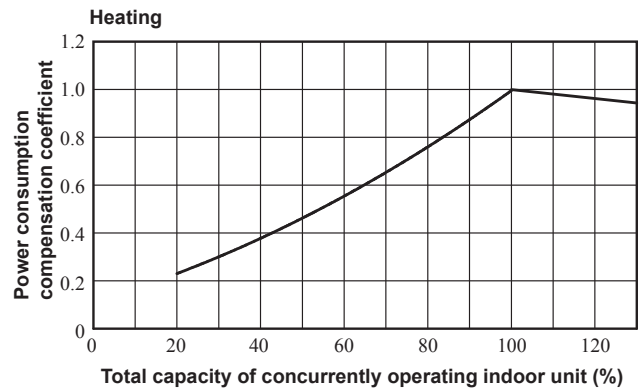
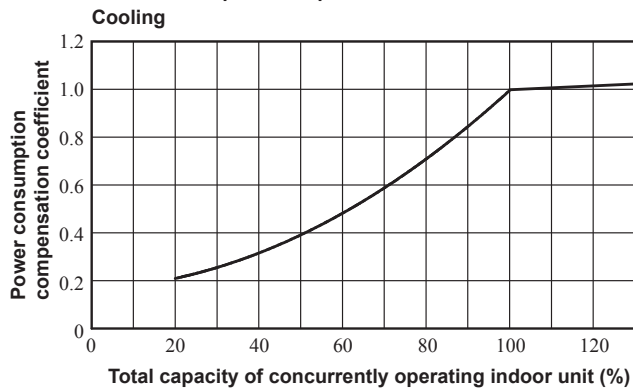

Model FDC1620KXZRE1

◆ Capability compensation coefficient

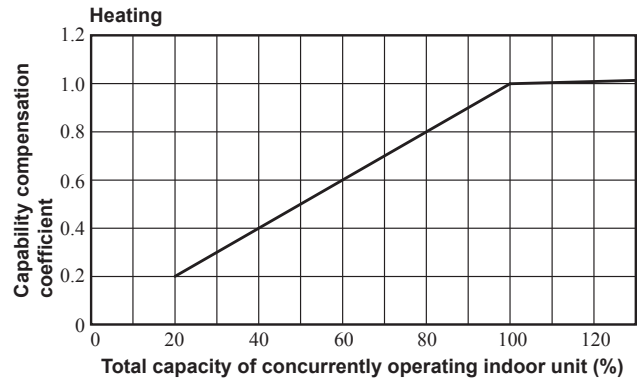
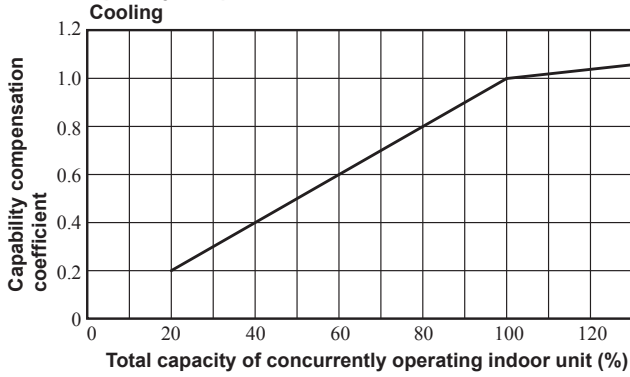

◆ Power consumption compensation coefficient

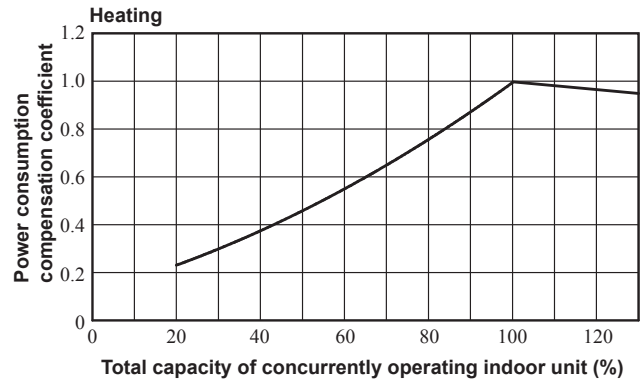
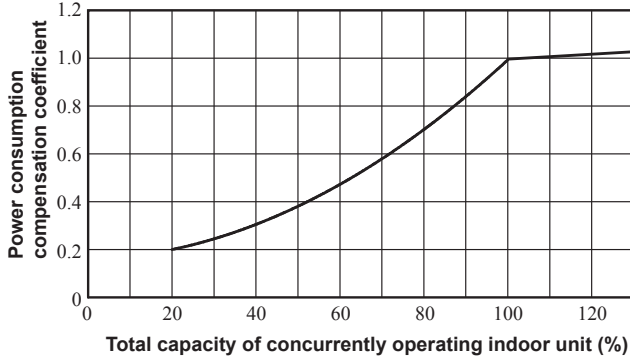

Model FDC1680KXZRE1

◆ Capability compensation coefficient

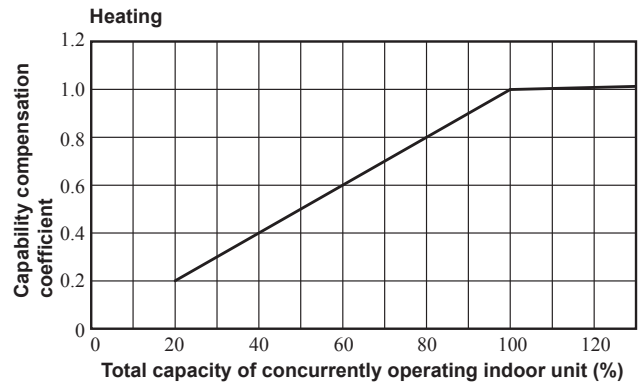
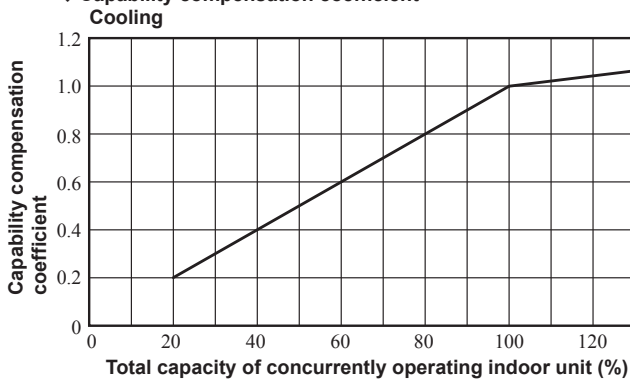

◆ Power consumption compensation coefficient

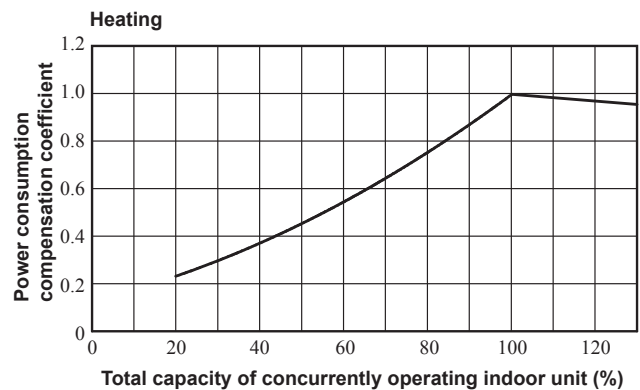
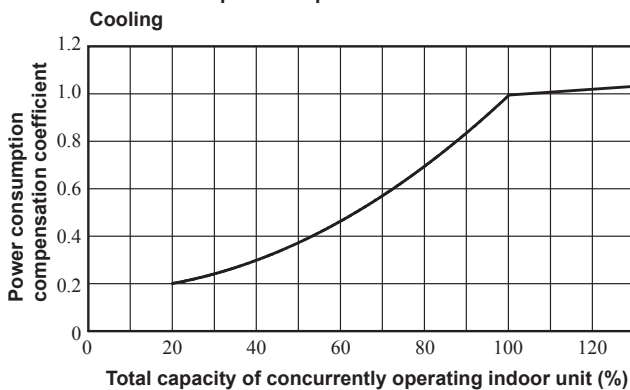

(f) The capacity compensation coefficient:
Cooling capacity in low temperature under operation of Anti-frost control.

(i) Indoor fan tap: P-Hi

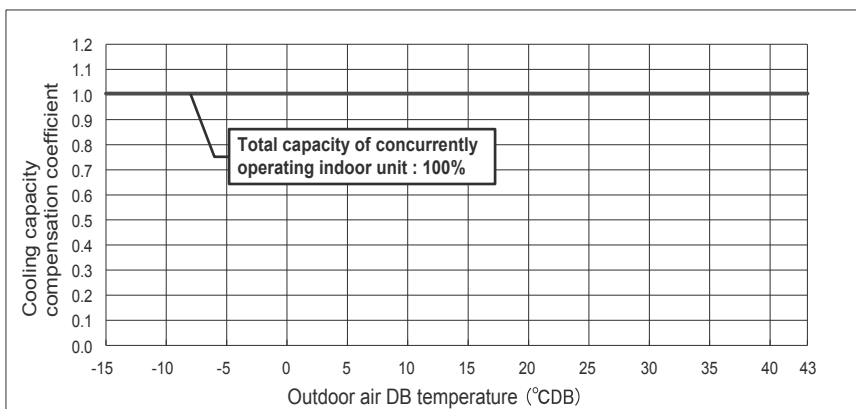
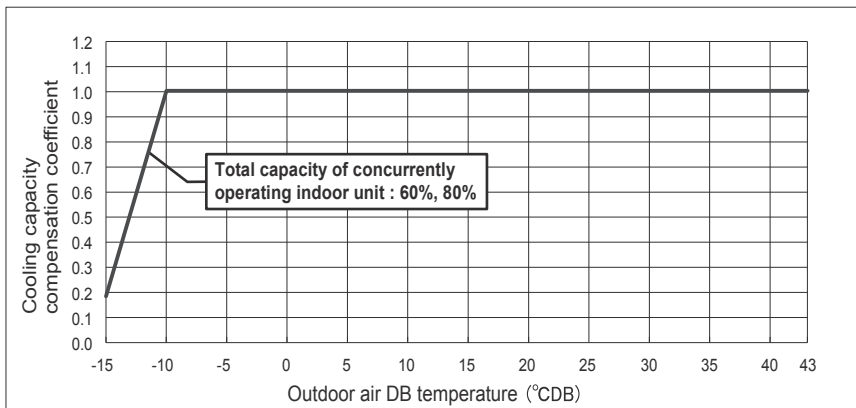
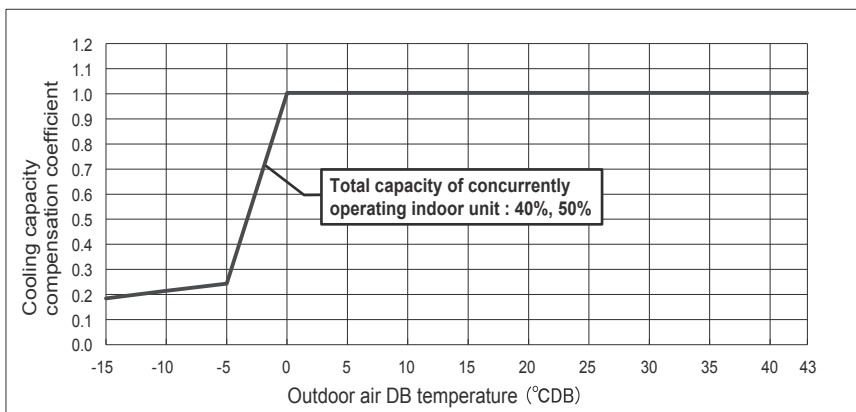
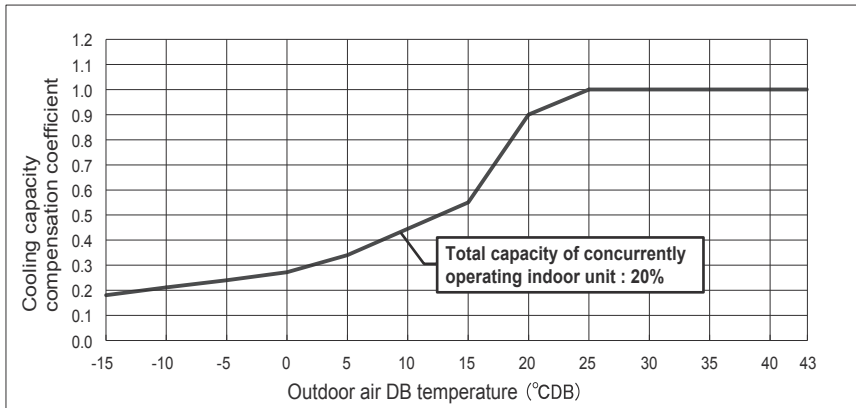

Capacity compensation coefficient is that of cooling capacity at each fan-tap.
 (Condition) Room temp: 27 °CDB/19°CWB
 (*) If room temp. is lower than 27°CDB/19°CWB, cooling capacity ratio tends to be smaller than values shown in graph.
 The lowest fan tap in the operating indoor units should be selected on above graph.

(ii) Indoor fan tap: Lo

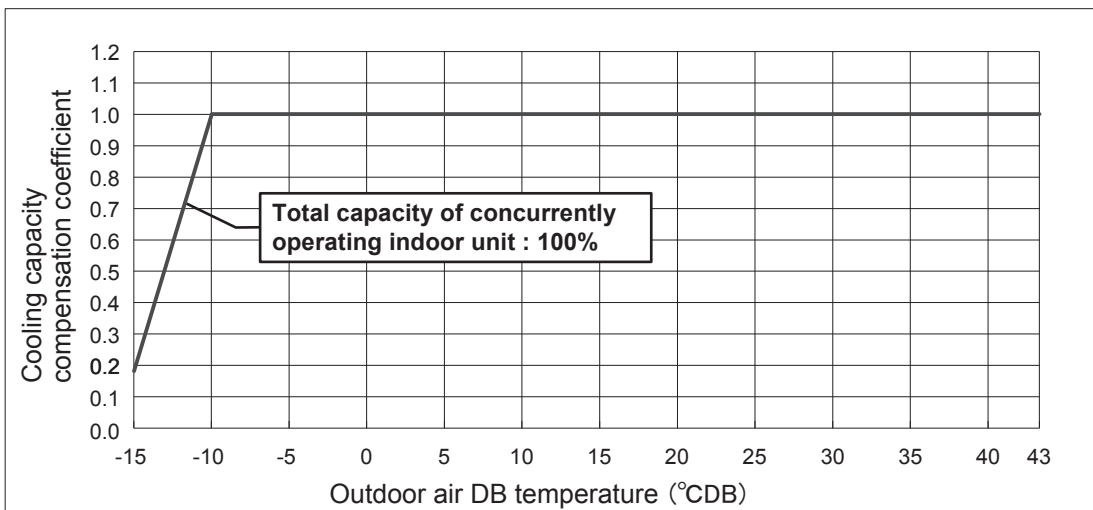
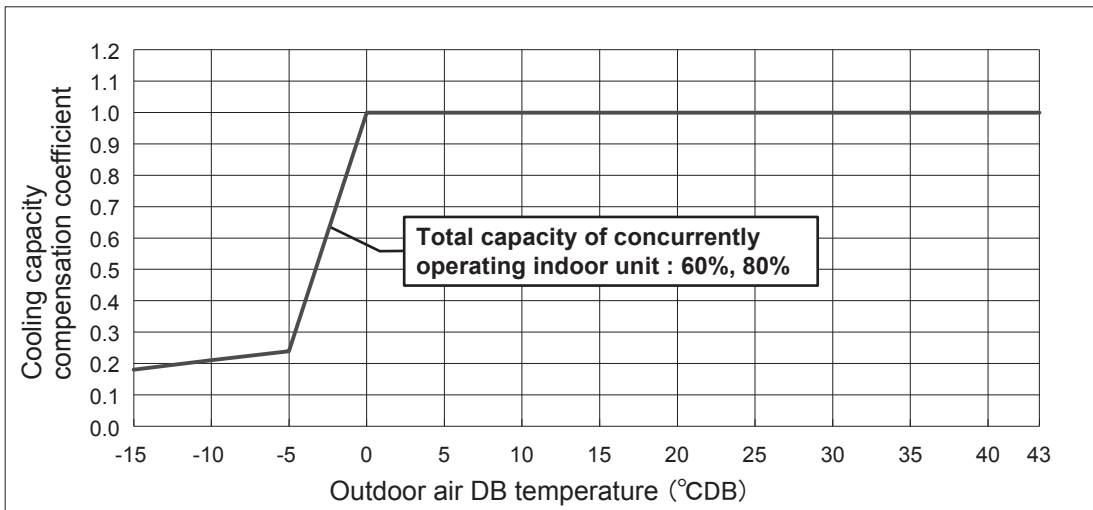
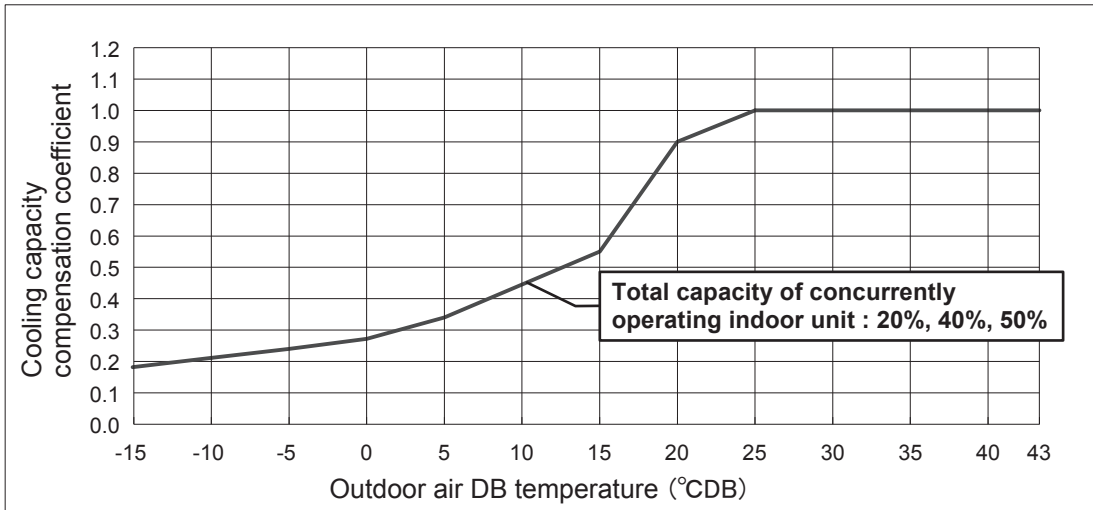

Capacity compensation coefficient is that of cooling capacity at each fan-tap.
 (Condition) Room temp: 27 °CDB/19°CWB
 (*) If room temp. is lower than 27°CDB/19°CWB, cooling capacity ratio tends to be smaller than values shown in graph.
 The lowest fan tap in the operating indoor units should be selected on above graph.

**(g)Cooling capacity compensation for simultaneous cooling and heating operations
Cooling capacity under the anti-frost control at low temperatures**

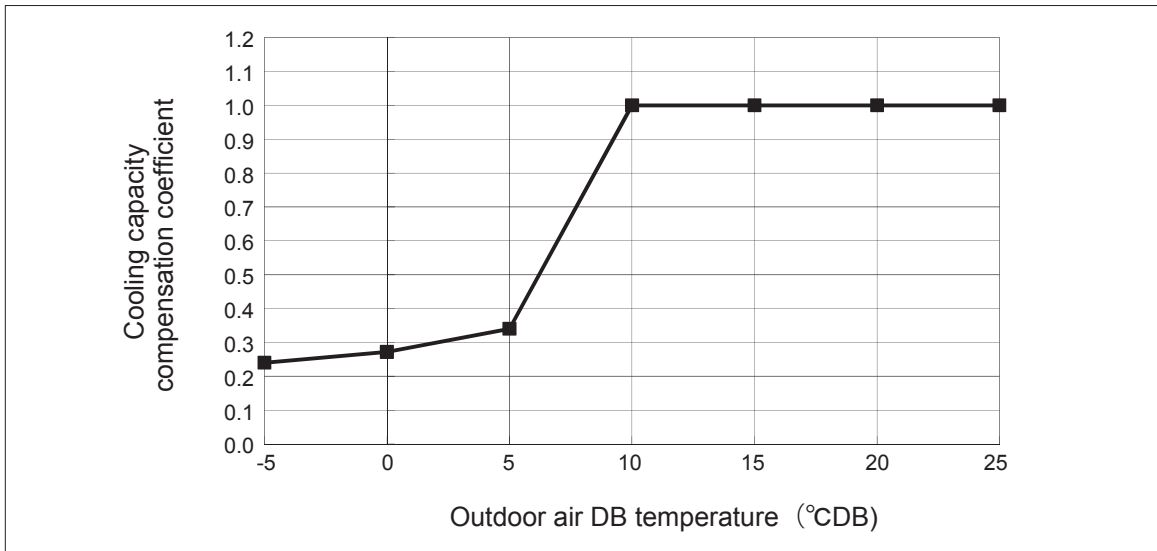

Cooling capacity compensation for simultaneous cooling and heating operations when the following conditions are met

- ①In the case of single operation,
Difference in operation capacities = Cooling operation capacity – Heating operation capacity ≥ 7.1 kW
In the case of combined operation, the difference in cooling and heating capacities must exceed that of single operation.
- ②Connection capacity: Connection capacity $\leq 130\%$
- ③Additional refrigerant quantity: Additional refrigerant charge quantity
(A: Standard additional refrigerant quantity +
B: Refrigerant quantity calculated based on pipe length x 1.4) is smaller than the following value:
FDC224,280KXZRE1 : 37.4kg
FDC400,450KXZRE1 : 50.0kg
FDC475,500,560,615,670KXZRE1 : 32.8kg
FDC735~ : 100kg

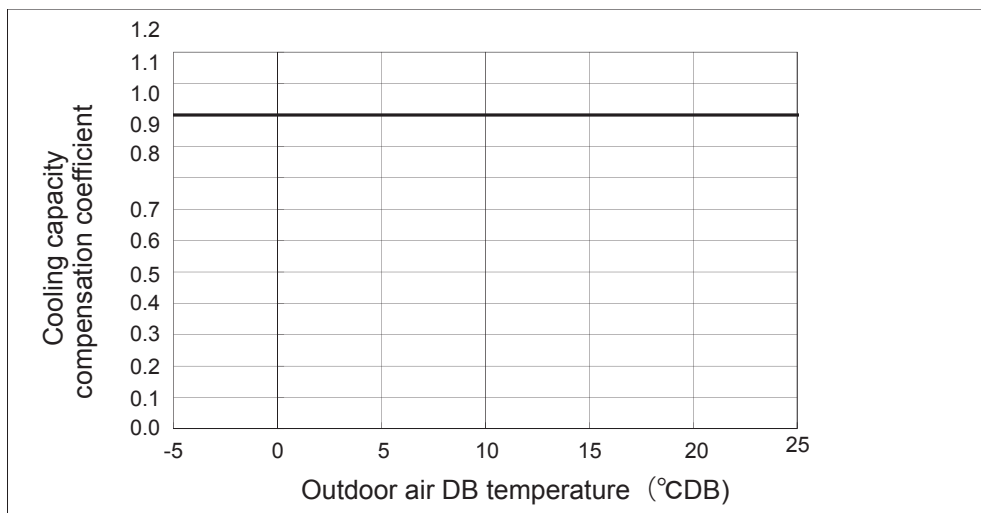

6. WARNINGS ON REFRIGERANT LEAKAGE

Check of concentration limit

The room in which the air conditioner is to be installed requires a design that in the event of refrigerant gas leaking out, its concentration will not exceed a set limit.

The refrigerant R410A which is used in the air conditioner is safe, without the toxicity or combustibility of ammonia, and is not restricted by laws to be imposed which protect the ozone layer. However, since it contains more than air, it poses the risk of suffocation if its concentration should rise excessively.

Suffocation from leakage of R410A is almost nonexistent. With the recent increase in the number of high concentration buildings, however, the installation of multi air conditioner systems is on the increase because of the need for effective use of floor space, individual control, energy conservation by curtailing heat and carrying power etc.

Most importantly, the multi air conditioner system is able to replenish a large amount of refrigerant compared with conventional individual air conditioners. If a single unit of the multi conditioner system is to be installed in a small room, select a suitable model and installation procedure so that if the refrigerant accidentally leaks out, its concentration does not reach the limit (and in the event of an emergency, measures can be made before injury can occur).

In a room where the concentration may exceed the limit, create an opening with adjacent rooms, or install mechanical ventilation combined with a gas leak detection device.

The concentration is as given below.

$$\frac{\text{Total amount of refrigerant (kg)}}{\text{Min. volume of the indoor unit installed room (m}^3\text{)}} \leq \text{Concentration limit (kg/m}^3\text{)}$$

The concentration limit of R410A which is used in multi air conditioners is 0.42kg/m³. (ISO5149)

Note(1) If there are 2 or more refrigerating systems in a single refrigerating device, the amounts of refrigerant should be as charged in each independent device.

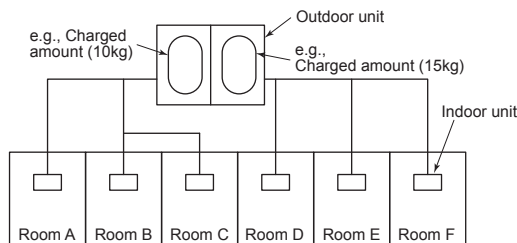

For the amount of charge in this example:
 The possible amount of leaked refrigerant gas in rooms A, B and C is 10kg.
 The possible amount of leaked refrigerant gas in rooms D, E and F is 15kg.

Important

Note(2) The standards for minimum room volume are as follows.

① No partition (shaded portion)

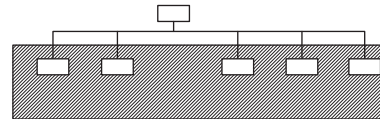

② When there is an effective opening with the adjacent room for ventilation of leaking refrigerant gas (opening without a door, or an opening 0.15% or larger than the respective floor spaces at the top or bottom of the door).

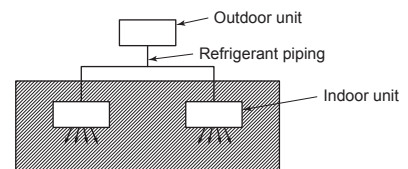

③ If an indoor unit is installed in each partitioned room and the refrigerant tubing is interconnected, the smallest of course becomes the object.

But when a mechanical ventilation is installed interlocked with a gas leakage detector in the smallest room where the density limit is exceeded, the volume of the next smallest room becomes the object.

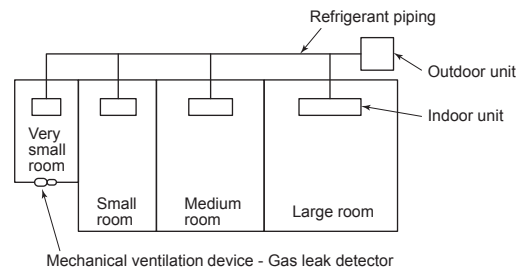

Note(3) The minimum indoor floor area compared with the amount of refrigerant is roughly as follows: (When the ceiling is 2.7m high)

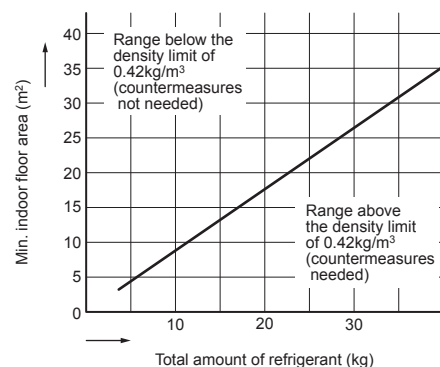

7. TECHNICAL INFORMATION

7.1 Outdoor unit

Model(s) : FDC224KXZRE1			
Outdoor side heat exchanger of air conditioner :		air	
Indoor side heat exchanger of air conditioner :		air	
Type : vapour compression			
if applicable : electric motor			
Item	Symbol	Value	Unit
Rated cooling capacity	Prated,c	22.4	kW
Declared cooling capacity for part load at given outdoor temperatures Tj and indoor 27°C/19°C(dry/wet bulb)			
Tj=+35°C	Pdc	22.4	kW
Tj=+30°C	Pdc	16.5	kW
Tj=+25°C	Pdc	10.6	kW
Tj=+20°C	Pdc	6.1	kW
Degradation coefficient for air conditioners**	Cdc	0.25	-
Power consumption in other than 'active mode'			
Off mode	P _{OFF}	0.043	kW
Thermostat-off mode	P _{TO}	0.000	kW
Other items			
Capacity control		variable	
Sound power level, outdoor	L _{WA}	73.0	dB
If engine driven: Emissions of nitrogen oxides	NO _x ***	-	mg/kWh fuel input GCV
GWP of the refrigerant		2088	kg CO _{2eq} (100years)
Seasonal space cooling energy efficiency η _{s,c}		247.9	%
Declared energy efficiency ratio or gas utilization efficiency / auxiliary energy factor for part load at given outdoor temperatures Tj			
Tj=+35°C	EERd or GUEc,bin / AEFc,bin	435.0	%
Tj=+30°C	EERd or GUEc,bin / AEFc,bin	554.0	%
Tj=+25°C	EERd or GUEc,bin / AEFc,bin	778.0	%
Tj=+20°C	EERd or GUEc,bin / AEFc,bin	812.0	%
Crankcase heater mode	P _{CK}	0.043	kW
Standby mode	P _{SB}	0.043	kW
For air-to-air air conditioner: air flow-rate,outdoor measured		13200	m ³ /h
Contact details Mitsubishi heavy industries thermal systems,LTD			
** If Cdc is not determined by measurement then the default degradation coefficient air conditioners shall be 0,25.			
*** from 26 September 2018			
Where information relates to multi-split air conditioners,the test result and performance data be obtained on the basis of the performance of the outdoor unit, with a combination of indoor unit(s) recommended by the manufacturer or importer.			

Information to identify the model(s) to which the information relates :				FDC224KXZRE1			
Outdoor side heat exchanger of heat pump :				air			
Indoor side heat exchanger of heat pump :				air			
Indication if the heater is equipped with a supplementary heater :				No			
if applicable :				electric motor			
Parameters shall be declared for the average heating season , parameters for the warmer and colder heating seasons are optional.							
Item	Symbol	Value	Unit	Item	Symbol	Value	Unit
Rated heating capacity	Prated,h	22.4	kW	Seasonal space heating energy efficiency ηs,h		159.3	%
Declared heating capacity for part load at indoor temperature 20°C and outdoor temperature Tj				Declared coefficient of performance or gas utilization efficiency / auxiliary energy factor for part load at given outdoor temperatures Tj			
Tj=-7°C	Pdh	16.7	kW	Tj=-7°C	COPd or GUEh,bin / AEFh,bin	298.0	%
Tj=+2°C	Pdh	10.2	kW	Tj=+2°C	COPd or GUEh,bin / AEFh,bin	378.0	%
Tj=+7°C	Pdh	6.7	kW	Tj=+7°C	COPd or GUEh,bin / AEFh,bin	545.0	%
Tj=+12°C	Pdh	5.0	kW	Tj=+12°C	COPd or GUEh,bin / AEFh,bin	573.0	%
Tbiv=bivalent temperature	Pdh	18.8	kW	Tbiv=bivalent temperature	COPd or GUEh,bin / AEFh,bin	255.0	%
TOL=operation limit	Pdh	11.4	kW	TOL=operation limit	COPd or GUEh,bin / AEFh,bin	193.0	%
For air-to-water heat pumps : Tj=-15°C (if TOL < -20°C)	Pdh	-	kW	For air-to-water heat pumps: Tj=-15°C (if TOL < -20°C)	COPd or GUEh,bin / AEFh,bin	-	%
Bivalent temperature	Tbiv	-10.0	°C	For water-to-air heat pumps: Operation limit		-	°C
Degradation coefficient heat pumps**	Cdh	0.25	-	Ta temperature			
Power consumption in modes other than 'active mode'				Supplementary heater back-up heating capacity			
Off mode	P _{OFF}	0.043	kW	elbu		-	kW
Thermostat-off mode	P _{TD}	0.043	kW	Type of energy input Standby mode	P _{SB}	0.043	kW
Crankcase heater mode	P _{CK}	0.043	kW				
Other items				For air-to-air heat pumps: air flow-rate,outdoor measured			
Capacity control		variable				12000	m3/h
Sound power level, outdoor measured	L _{WA}	75.0	dB	For water-/brine-to-air heat pumps : Rated brine or water flow-rate, outdoor side heat exchanger		-	m3/h
Emissions of nitrogen oxides(if applicable)	NOx ***	-	mg/kWh fuel input GCV				
GWP of the refrigerant		2088	kg CO ₂ eq (100years)				
Contact details		Mitsubishi heavy industries thermal systems,LTD					
** If Cdh is not determined by measurement then the default degradation coefficient air conditioners shall be 0,25.							
*** from 26 September 2018							
Where information relates to multi-split air conditioners,the test result and performance data be obtained on the basis of the performance of the outdoor unit, with a combination of indoor unit(s) recommended by the manufacturer or importer.							

Model(s) : FDC280KXZRE1							
Outdoor side heat exchanger of air conditioner :				air			
Indoor side heat exchanger of air conditioner :				air			
Type : vapour compression							
if applicable : electric motor							
Item	Symbol	Value	Unit	Item	Symbol	Value	Unit
Rated cooling capacity	Prated,c	28.0	kW	Seasonal space cooling energy efficiency ηs,c		241.2	%
Declared cooling capacity for part load at given outdoor temperatures Tj and indoor 27°C/19°C(dry/wet bulb)				Declared energy efficiency ratio or gas utilization efficiency / auxiliary energy factor for part load at given outdoor temperatures Tj			
Tj=+35°C	Pdc	28.0	kW	Tj=+35°C	EERd or GUEc,bin / AEFc,bin	379.0	%
Tj=+30°C	Pdc	20.6	kW	Tj=+30°C	EERd or GUEc,bin / AEFc,bin	508.0	%
Tj=+25°C	Pdc	13.2	kW	Tj=+25°C	EERd or GUEc,bin / AEFc,bin	728.0	%
Tj=+20°C	Pdc	6.6	kW	Tj=+20°C	EERd or GUEc,bin / AEFc,bin	868.0	%
Degradation coefficient for air conditioners**	Cdc	0.25	-				
Power consumption in other than 'active mode'							
Off mode	P _{OFF}	0.043	kW	Crankcase heater mode	P _{CK}	0.043	kW
Thermostat-off mode	P _{TO}	0.000	kW	Standby mode	P _{SB}	0.043	kW
Other items				For air-to-air air conditioner:			
Capacity control		variable		air flow-rate,outdoor measured		13200	m ³ /h
Sound power level, outdoor	L _{WA}	74.0	dB				
If engine driven: Emissions of nitrogen oxides	NOx ***	-	mg/kWh fuel input GCV				
GWP of the refrigerant		2088	kg CO _{2eq} (100years)				
Contact details	Mitsubishi heavy industries thermal systems,LTD						
** If Cdc is not determined by measurement then the default degradation coefficient air conditioners shall be 0,25.							
*** from 26 September 2018							
Where information relates to multi-split air conditioners,the test result and performance data be obtained on the basis of the performance of the outdoor unit, with a combination of indoor unit(s) recommended by the manufacturer or importer.							

Information to identify the model(s) to which the information relates :				FDC280KXZRE1			
Outdoor side heat exchanger of heat pump :				air			
Indoor side heat exchanger of heat pump :				air			
Indication if the heater is equipped with a supplementary heater :				No			
if applicable :				electric motor			
Parameters shall be declared for the average heating season , parameters for the warmer and colder heating seasons are optional.							
Item	Symbol	Value	Unit	Item	Symbol	Value	Unit
Rated heating capacity	Prated,h	28.0	kW	Seasonal space heating energy efficiency ηs,h		157.7	%
Declared heating capacity for part load at indoor temperature 20°C and outdoor temperature Tj				Declared coefficient of performance or gas utilization efficiency / auxiliary energy factor for part load at given outdoor temperatures Tj			
Tj=-7°C	Pdh	18.3	kW	Tj=-7°C	COPd or GUEh,bin / AEFh,bin	277.0	%
Tj=+2°C	Pdh	10.9	kW	Tj=+2°C	COPd or GUEh,bin / AEFh,bin	385.0	%
Tj=+7°C	Pdh	7.0	kW	Tj=+7°C	COPd or GUEh,bin / AEFh,bin	532.0	%
Tj=+12°C	Pdh	5.0	kW	Tj=+12°C	COPd or GUEh,bin / AEFh,bin	565.0	%
Tbiv=bivalent temperature	Pdh	19.9	kW	Tbiv=bivalent temperature	COPd or GUEh,bin / AEFh,bin	247.0	%
TOL=operation limit	Pdh	11.9	kW	TOL=operation limit	COPd or GUEh,bin / AEFh,bin	183.0	%
For air-to-water heat pumps : Tj=-15°C (if TOL < -20°C)	Pdh	-	kW	For air-to-water heat pumps: Tj=-15°C (if TOL < -20°C)	COPd or GUEh,bin / AEFh,bin	-	%
Bivalent temperature	Tbiv	-10.0	°C	For water-to-air heat pumps: Operation limit		-	°C
Degradation coefficient heat pumps**	Cdh	0.25	-	Ta temperature			
Power consumption in modes other than 'active mode'				Supplementary heater back-up heating capacity			
Off mode	POFF	0.043	kW	elbu		-	kW
Thermostat-off mode	PTD	0.043	kW	Type of energy input Standby mode	Psb	0.043	kW
Crankcase heater mode	PCK	0.043	kW				
Other items				For air-to-air heat pumps: air flow-rate,outdoor measured			
Capacity control		variable				12000	m3/h
Sound power level, outdoor measured	LWA	76.0	dB	For water-/brine-to-air heat pumps : Rated brine or water flow-rate, outdoor side heat exchanger		-	m3/h
Emissions of nitrogen oxides(if applicable)	NOx ***	-	mg/kWh fuel input GCV				
GWP of the refrigerant		2088	kg CO2eq (100years)				
Contact details		Mitsubishi heavy industries thermal systems,LTD					
** If Cdh is not determined by measurement then the default degradation coefficient air conditioners shall be 0,25.							
*** from 26 September 2018							
Where information relates to multi-split air conditioners,the test result and performance data be obtained on the basis of the performance of the outdoor unit, with a combination of indoor unit(s) recommended by the manufacturer or importer.							

Model(s) : FDC335KXZRE1			
Outdoor side heat exchanger of air conditioner :		air	
Indoor side heat exchanger of air conditioner :		air	
Type : vapour compression			
if applicable : electric motor			
Item	Symbol	Value	Unit
Rated cooling capacity	Prated,c	33.5	kW
Declared cooling capacity for part load at given outdoor temperatures Tj and indoor 27°C/19°C(dry/wet bulb)			
Tj=+35°C	Pdc	33.5	kW
Tj=+30°C	Pdc	24.6	kW
Tj=+25°C	Pdc	15.8	kW
Tj=+20°C	Pdc	9.2	kW
Degradation coefficient for air conditioners**	Cdc	0.25	-
Power consumption in other than 'active mode'			
Off mode	P _{OFF}	0.043	kW
Thermostat-off mode	P _{TO}	0.000	kW
Other items			
Capacity control		variable	
Sound power level, outdoor	L _{WA}	81.0	dB
If engine driven: Emissions of nitrogen oxides	NO _x ***	-	mg/kWh fuel input GCV
GWP of the refrigerant		2088	kg CO _{2eq} (100years)
Seasonal space cooling energy efficiency ηs,c		277.0	%
Declared energy efficiency ratio or gas utilization efficiency / auxiliary energy factor for part load at given outdoor temperatures Tj			
Tj=+35°C	EERd or GUEc,bin / AEFc,bin	347.0	%
Tj=+30°C	EERd or GUEc,bin / AEFc,bin	504.0	%
Tj=+25°C	EERd or GUEc,bin / AEFc,bin	765.0	%
Tj=+20°C	EERd or GUEc,bin / AEFc,bin	1750.0	%
Crankcase heater mode		P _{CK}	0.043 kW
Standby mode		P _{SB}	0.043 kW
For air-to-air air conditioner: air flow-rate,outdoor measured		16800	m ³ /h
Contact details		Mitsubishi heavy industries thermal systems,LTD	
** If Cdc is not determined by measurement then the default degradation coefficient air conditioners shall be 0,25.			
*** from 26 September 2018			
Where information relates to multi-split air conditioners,the test result and performance data be obtained on the basis of the performance of the outdoor unit, with a combination of indoor unit(s) recommended by the manufacturer or importer.			

Information to identify the model(s) to which the information relates :				FDC335KXZRE1			
Outdoor side heat exchanger of heat pump :				air			
Indoor side heat exchanger of heat pump :				air			
Indication if the heater is equipped with a supplementary heater :				No			
if applicable :				electric motor			
Parameters shall be declared for the average heating season , parameters for the warmer and colder heating seasons are optional.							
Item	Symbol	Value	Unit	Item	Symbol	Value	Unit
Rated heating capacity	Prated,h	33.5	kW	Seasonal space heating energy efficiency ηs,h		190.7	%
Declared heating capacity for part load at indoor temperature 20°C and outdoor temperature Tj				Declared coefficient of performance or gas utilization efficiency / auxiliary energy factor for part load at given outdoor temperatures Tj			
Tj=-7°C	Pdh	22.4	kW	Tj=-7°C	COPd or GUEh,bin / AEFh,bin	325.0	%
Tj=+2°C	Pdh	13.7	kW	Tj=+2°C	COPd or GUEh,bin / AEFh,bin	462.0	%
Tj=+7°C	Pdh	9.0	kW	Tj=+7°C	COPd or GUEh,bin / AEFh,bin	632.0	%
Tj=+12°C	Pdh	6.3	kW	Tj=+12°C	COPd or GUEh,bin / AEFh,bin	805.0	%
Tbiv=bivalent temperature	Pdh	25.6	kW	Tbiv=bivalent temperature	COPd or GUEh,bin / AEFh,bin	274.0	%
TOL=operation limit	Pdh	18.8	kW	TOL=operation limit	COPd or GUEh,bin / AEFh,bin	229.0	%
For air-to-water heat pumps : Tj=-15°C (if TOL < -20°C)	Pdh	-	kW	For air-to-water heat pumps: Tj=-15°C (if TOL < -20°C)	COPd or GUEh,bin / AEFh,bin	-	%
Bivalent temperature	Tbiv	-10.0	°C	For water-to-air heat pumps: Operation limit		-	°C
Degradation coefficient heat pumps**	Cdh	0.25	-	Ta temperature			
Power consumption in modes other than 'active mode'				Supplementary heater back-up heating capacity			
Off mode	P _{OFF}	0.043	kW	elbu		-	kW
Thermostat-off mode	P _{TD}	0.043	kW	Type of energy input Standby mode	P _{SB}	0.043	kW
Crankcase heater mode	P _{CK}	0.043	kW				
Other items				For air-to-air heat pumps: air flow-rate,outdoor measured			
Capacity control		variable				12000	m3/h
Sound power level, outdoor measured	L _{WA}	77.0	dB	For water-/brine-to-air heat pumps : Rated brine or water flow-rate, outdoor side heat exchanger		-	m3/h
Emissions of nitrogen oxides(if applicable)	NOx ***	-	mg/kWh fuel input GCV				
GWP of the refrigerant		2088	kg CO _{2eq} (100years)				
Contact details		Mitsubishi heavy industries thermal systems,LTD					
** If Cdh is not determined by measurement then the default degradation coefficient air conditioners shall be 0,25.							
*** from 26 September 2018							
Where information relates to multi-split air conditioners,the test result and performance data be obtained on the basis of the performance of the outdoor unit, with a combination of indoor unit(s) recommended by the manufacturer or importer.							

Model(s) : FDC400KXZRE1			
Outdoor side heat exchanger of air conditioner :		air	
Indoor side heat exchanger of air conditioner :		air	
Type : vapour compression			
if applicable : electric motor			
Item	Symbol	Value	Unit
Rated cooling capacity	Prated,c	40.0	kW
Declared cooling capacity for part load at given outdoor temperatures Tj and indoor 27°C/19°C(dry/wet bulb)			
Tj=+35°C	Pdc	40.0	kW
Tj=+30°C	Pdc	29.4	kW
Tj=+25°C	Pdc	18.9	kW
Tj=+20°C	Pdc	13.2	kW
Degradation coefficient for air conditioners**	Cdc	0.25	-
Power consumption in other than 'active mode'			
Off mode	P _{OFF}	0.050	kW
Thermostat-off mode	P _{TO}	0.000	kW
Other items			
Capacity control		variable	
Sound power level, outdoor	L _{WA}	81.0	dB
If engine driven: Emissions of nitrogen oxides	NOx ***	-	mg/kWh fuel input GCV
GWP of the refrigerant		2088	kg CO _{2eq} (100years)
Seasonal space cooling energy efficiency ηs,c		250.5	%
Declared energy efficiency ratio or gas utilization efficiency / auxiliary energy factor for part load at given outdoor temperatures Tj			
Tj=+35°C	EERd or GUEc,bin / AEFc,bin	346.0	%
Tj=+30°C	EERd or GUEc,bin / AEFc,bin	532.0	%
Tj=+25°C	EERd or GUEc,bin / AEFc,bin	687.0	%
Tj=+20°C	EERd or GUEc,bin / AEFc,bin	1170.0	%
Crankcase heater mode		P _{CK}	0.050 kW
Standby mode		P _{SB}	0.050 kW
For air-to-air air conditioner: air flow-rate,outdoor measured		16800	m ³ /h
Contact details Mitsubishi heavy industries thermal systems,LTD			
** If Cdc is not determined by measurement then the default degradation coefficient air conditioners shall be 0,25.			
*** from 26 September 2018			
Where information relates to multi-split air conditioners,the test result and performance data be obtained on the basis of the performance of the outdoor unit, with a combination of indoor unit(s) recommended by the manufacturer or importer.			

Information to identify the model(s) to which the information relates :				FDC400KXZRE1			
Outdoor side heat exchanger of heat pump :				air			
Indoor side heat exchanger of heat pump :				air			
Indication if the heater is equipped with a supplementary heater :				No			
if applicable :				electric motor			
Parameters shall be declared for the average heating season , parameters for the warmer and colder heating seasons are optional.							
Item	Symbol	Value	Unit	Item	Symbol	Value	Unit
Rated heating capacity	Prated,h	40.0	kW	Seasonal space heating energy efficiency ηs,h		165.9	%
Declared heating capacity for part load at indoor temperature 20°C and outdoor temperature Tj				Declared coefficient of performance or gas utilization efficiency / auxiliary energy factor for part load at given outdoor temperatures Tj			
Tj=-7°C	Pdh	31.3	kW	Tj=-7°C	COPd or GUEh,bin / AEFh,bin	301.0	%
Tj=+2°C	Pdh	19.1	kW	Tj=+2°C	COPd or GUEh,bin / AEFh,bin	381.0	%
Tj=+7°C	Pdh	12.3	kW	Tj=+7°C	COPd or GUEh,bin / AEFh,bin	564.0	%
Tj=+12°C	Pdh	7.2	kW	Tj=+12°C	COPd or GUEh,bin / AEFh,bin	775.0	%
Tbiv=bivalent temperature	Pdh	35.6	kW	Tbiv=bivalent temperature	COPd or GUEh,bin / AEFh,bin	269.0	%
TOL=operation limit	Pdh	26.9	kW	TOL=operation limit	COPd or GUEh,bin / AEFh,bin	223.0	%
For air-to-water heat pumps : Tj=-15°C (if TOL < -20°C)	Pdh	-	kW	For air-to-water heat pumps: Tj=-15°C (if TOL < -20°C)	COPd or GUEh,bin / AEFh,bin	-	%
Bivalent temperature	Tbiv	-10.0	°C	For water-to-air heat pumps: Operation limit		-	°C
Degradation coefficient heat pumps**	Cdh	0.25	-	Ta temperature			
Power consumption in modes other than 'active mode'				Supplementary heater back-up heating capacity			
Off mode	P _{OFF}	0.050	kW	elbu		-	kW
Thermostat-off mode	P _{TD}	0.050	kW	Type of energy input Standby mode	P _{SB}	0.050	kW
Crankcase heater mode	P _{CK}	0.050	kW				
Other items				For air-to-air heat pumps: air flow-rate,outdoor measured			
Capacity control		variable				15600	m ³ /h
Sound power level, outdoor measured	L _{WA}	83.0	dB	For water-/brine-to-air heat pumps : Rated brine or water flow-rate, outdoor side heat exchanger		-	m ³ /h
Emissions of nitrogen oxides(if applicable)	NO _x ***	-	mg/kWh fuel input GCV				
GWP of the refrigerant		2088	kg CO ₂ eq (100years)				
Contact details		Mitsubishi heavy industries thermal systems,LTD					
** If Cdh is not determined by measurement then the default degradation coefficient air conditioners shall be 0,25.							
*** from 26 September 2018							
Where information relates to multi-split air conditioners,the test result and performance data be obtained on the basis of the performance of the outdoor unit, with a combination of indoor unit(s) recommended by the manufacturer or importer.							

Model(s) : FDC450KXZRE1							
Outdoor side heat exchanger of air conditioner :				air			
Indoor side heat exchanger of air conditioner :				air			
Type : vapour compression							
if applicable : electric motor							
Item	Symbol	Value	Unit	Item	Symbol	Value	Unit
Rated cooling capacity	Prated,c	45.0	kW	Seasonal space cooling energy efficiency ηs,c		238.5	%
Declared cooling capacity for part load at given outdoor temperatures Tj and indoor 27°C/19°C(dry/wet bulb)				Declared energy efficiency ratio or gas utilization efficiency / auxiliary energy factor for part load at given outdoor temperatures Tj			
Tj=+35°C	Pdc	45.0	kW	Tj=+35°C	EERd or GUEc,bin / AEFc,bin	311.0	%
Tj=+30°C	Pdc	33.1	kW	Tj=+30°C	EERd or GUEc,bin / AEFc,bin	494.0	%
Tj=+25°C	Pdc	21.3	kW	Tj=+25°C	EERd or GUEc,bin / AEFc,bin	621.0	%
Tj=+20°C	Pdc	13.5	kW	Tj=+20°C	EERd or GUEc,bin / AEFc,bin	1260.0	%
Degradation coefficient for air conditioners**	Cdc	0.25	-				
Power consumption in other than 'active mode'							
Off mode	P _{OFF}	0.050	kW	Crankcase heater mode	P _{CK}	0.050	kW
Thermostat-off mode	P _{TO}	0.000	kW	Standby mode	P _{SB}	0.050	kW
Other items				For air-to-air air conditioner:			
Capacity control		variable		air flow-rate,outdoor measured		16800	m3/h
Sound power level, outdoor	L _{WA}	82.0	dB				
If engine driven: Emissions of nitrogen oxides	NOx ***	-	mg/kWh fuel input GCV				
GWP of the refrigerant		2088	kg CO _{2eq} (100years)				
Contact details	Mitsubishi heavy industries thermal systems,LTD						
** If Cdc is not determined by measurement then the default degradation coefficient air conditioners shall be 0,25.							
*** from 26 September 2018							
Where information relates to multi-split air conditioners,the test result and performance data be obtained on the basis of the performance of the outdoor unit, with a combination of indoor unit(s) recommended by the manufacturer or importer.							

Information to identify the model(s) to which the information relates :				FDC450KXZRE1			
Outdoor side heat exchanger of heat pump :				air			
Indoor side heat exchanger of heat pump :				air			
Indication if the heater is equipped with a supplementary heater :				No			
if applicable :				electric motor			
Parameters shall be declared for the average heating season , parameters for the warmer and colder heating seasons are optional.							
Item	Symbol	Value	Unit	Item	Symbol	Value	Unit
Rated heating capacity	Prated,h	45.0	kW	Seasonal space heating energy efficiency ηs,h		170.4	%
Declared heating capacity for part load at indoor temperature 20°C and outdoor temperature Tj				Declared coefficient of performance or gas utilization efficiency / auxiliary energy factor for part load at given outdoor temperatures Tj			
Tj=-7°C	Pdh	31.0	kW	Tj=-7°C	COPd or GUEh,bin / AEFh,bin	310.0	%
Tj=+2°C	Pdh	19.1	kW	Tj=+2°C	COPd or GUEh,bin / AEFh,bin	388.0	%
Tj=+7°C	Pdh	12.4	kW	Tj=+7°C	COPd or GUEh,bin / AEFh,bin	587.0	%
Tj=+12°C	Pdh	7.3	kW	Tj=+12°C	COPd or GUEh,bin / AEFh,bin	802.0	%
Tbiv=bivalent temperature	Pdh	35.3	kW	Tbiv=bivalent temperature	COPd or GUEh,bin / AEFh,bin	274.0	%
TOL=operation limit	Pdh	26.8	kW	TOL=operation limit	COPd or GUEh,bin / AEFh,bin	228.0	%
For air-to-water heat pumps : Tj=-15°C (if TOL < -20°C)	Pdh	-	kW	For air-to-water heat pumps: Tj=-15°C (if TOL < -20°C)	COPd or GUEh,bin / AEFh,bin	-	%
Bivalent temperature	Tbiv	-10.0	°C	For water-to-air heat pumps: Operation limit		-	°C
Degradation coefficient heat pumps**	Cdh	0.25	-	Ta temperature			
Power consumption in modes other than 'active mode'				Supplementary heater back-up heating capacity			
Off mode	P _{OFF}	0.050	kW	elbu	-	kW	
Thermostat-off mode	P _{TD}	0.050	kW	Type of energy input Standby mode	P _{SB}	0.050	kW
Crankcase heater mode	P _{CK}	0.050	kW				
Other items				For air-to-air heat pumps: air flow-rate,outdoor measured			
Capacity control		variable				15600	m ³ /h
Sound power level, outdoor measured	L _{WA}	83.0	dB	For water-/brine-to-air heat pumps : Rated brine or water flow-rate, outdoor side heat exchanger		-	m ³ /h
Emissions of nitrogen oxides(if applicable)	NOx ***	-	mg/kWh fuel input GCV				
GWP of the refrigerant		2088	kg CO ₂ eq (100years)				
Contact details				Mitsubishi heavy industries thermal systems,LTD			
** If Cdh is not determined by measurement then the default degradation coefficient air conditioners shall be 0,25.							
*** from 26 September 2018							
Where information relates to multi-split air conditioners,the test result and performance data be obtained on the basis of the performance of the outdoor unit, with a combination of indoor unit(s) recommended by the manufacturer or importer.							

Model(s) : FDC475KXZRE1							
Outdoor side heat exchanger of air conditioner :				air			
Indoor side heat exchanger of air conditioner :				air			
Type : vapour compression							
if applicable : electric motor							
Item	Symbol	Value	Unit	Item	Symbol	Value	Unit
Rated cooling capacity	Prated,c	47.5	kW	Seasonal space cooling energy efficiency ηs,c		261.0	%
Declared cooling capacity for part load at given outdoor temperatures Tj and indoor 27°C/19°C(dry/wet bulb)				Declared energy efficiency ratio or gas utilization efficiency / auxiliary energy factor for part load at given outdoor temperatures Tj			
Tj=+35°C	Pdc	47.5	kW	Tj=+35°C	EERd or GUEc,bin / AEFc,bin	320.0	%
Tj=+30°C	Pdc	34.9	kW	Tj=+30°C	EERd or GUEc,bin / AEFc,bin	520.0	%
Tj=+25°C	Pdc	22.3	kW	Tj=+25°C	EERd or GUEc,bin / AEFc,bin	617.0	%
Tj=+20°C	Pdc	10.0	kW	Tj=+20°C	EERd or GUEc,bin / AEFc,bin	2060.0	%
Degradation coefficient for air conditioners**	Cdc	0.25	-				
Power consumption in other than 'active mode'							
Off mode	P _{OFF}	0.082	kW	Crankcase heater mode	P _{CK}	0.082	kW
Thermostat-off mode	P _{TO}	0.000	kW	Standby mode	P _{SB}	0.082	kW
Other items				For air-to-air air conditioner:			
Capacity control		variable		air flow-rate,outdoor measured		16800	m3/h
Sound power level, outdoor	L _{WA}	81.0	dB				
If engine driven: Emissions of nitrogen oxides	NOx ***	-	mg/kWh fuel input GCV				
GWP of the refrigerant		2088	kg CO _{2eq} (100years)				
Contact details	Mitsubishi heavy industries thermal systems,LTD						
** If Cdc is not determined by measurement then the default degradation coefficient air conditioners shall be 0,25.							
*** from 26 September 2018							
Where information relates to multi-split air conditioners,the test result and performance data be obtained on the basis of the performance of the outdoor unit, with a combination of indoor unit(s) recommended by the manufacturer or importer.							

Information to identify the model(s) to which the information relates :				FDC475KXZRE1			
Outdoor side heat exchanger of heat pump :				air			
Indoor side heat exchanger of heat pump :				air			
Indication if the heater is equipped with a supplementary heater :				No			
if applicable :				electric motor			
Parameters shall be declared for the average heating season , parameters for the warmer and colder heating seasons are optional.							
Item	Symbol	Value	Unit	Item	Symbol	Value	Unit
Rated heating capacity	Prated,h	47.5	kW	Seasonal space heating energy efficiency ηs,h		168.0	%
Declared heating capacity for part load at indoor temperature 20°C and outdoor temperature Tj				Declared coefficient of performance or gas utilization efficiency / auxiliary energy factor for part load at given outdoor temperatures Tj			
Tj=-7°C	Pdh	34.8	kW	Tj=-7°C	COPd or GUEh,bin / AEFh,bin	294.0	%
Tj=+2°C	Pdh	21.4	kW	Tj=+2°C	COPd or GUEh,bin / AEFh,bin	378.0	%
Tj=+7°C	Pdh	14.0	kW	Tj=+7°C	COPd or GUEh,bin / AEFh,bin	596.0	%
Tj=+12°C	Pdh	6.6	kW	Tj=+12°C	COPd or GUEh,bin / AEFh,bin	855.0	%
Tbiv=bivalent temperature	Pdh	39.5	kW	Tbiv=bivalent temperature	COPd or GUEh,bin / AEFh,bin	254.0	%
TOL=operation limit	Pdh	29.0	kW	TOL=operation limit	COPd or GUEh,bin / AEFh,bin	214.0	%
For air-to-water heat pumps : Tj=-15°C (if TOL < -20°C)	Pdh	-	kW	For air-to-water heat pumps: Tj=-15°C (if TOL < -20°C)	COPd or GUEh,bin / AEFh,bin	-	%
Bivalent temperature	Tbiv	-10.0	°C	For water-to-air heat pumps: Operation limit		-	°C
Degradation coefficient heat pumps**	Cdh	0.25	-	Ta temperature			
Power consumption in modes other than 'active mode'				Supplementary heater back-up heating capacity			
Off mode	P _{OFF}	0.082	kW	elbu		-	kW
Thermostat-off mode	P _{TD}	0.082	kW	Type of energy input Standby mode	P _{SB}	0.082	kW
Crankcase heater mode	P _{CK}	0.082	kW				
Other items				For air-to-air heat pumps: air flow-rate,outdoor measured			
Capacity control		variable				15600	m ³ /h
Sound power level, outdoor measured	L _{WA}	82.0	dB	For water-/brine-to-air heat pumps : Rated brine or water flow-rate, outdoor side heat exchanger		-	m ³ /h
Emissions of nitrogen oxides(if applicable)	NOx ***	-	mg/kWh fuel input GCV				
GWP of the refrigerant		2088	kg CO ₂ eq (100years)				
Contact details		Mitsubishi heavy industries thermal systems,LTD					
** If Cdh is not determined by measurement then the default degradation coefficient air conditioners shall be 0,25.							
*** from 26 September 2018							
Where information relates to multi-split air conditioners,the test result and performance data be obtained on the basis of the performance of the outdoor unit, with a combination of indoor unit(s) recommended by the manufacturer or importer.							

Model(s) : FDC500KXZRE1			
Outdoor side heat exchanger of air conditioner :		air	
Indoor side heat exchanger of air conditioner :		air	
Type : vapour compression			
if applicable : electric motor			
Item	Symbol	Value	Unit
Rated cooling capacity	Prated,c	50.0	kW
Declared cooling capacity for part load at given outdoor temperatures Tj and indoor 27°C/19°C(dry/wet bulb)			
Tj=+35°C	Pdc	50.0	kW
Tj=+30°C	Pdc	36.8	kW
Tj=+25°C	Pdc	23.6	kW
Tj=+20°C	Pdc	10.5	kW
Degradation coefficient for air conditioners**	Cdc	0.25	-
Power consumption in other than 'active mode'			
Off mode	P _{OFF}	0.082	kW
Thermostat-off mode	P _{TO}	0.000	kW
Other items			
Capacity control		variable	
Sound power level, outdoor	L _{WA}	81.0	dB
If engine driven: Emissions of nitrogen oxides	NOx ***	-	mg/kWh fuel input GCV
GWP of the refrigerant		2088	kg CO _{2eq} (100years)
Seasonal space cooling energy efficiency ηs,c		277.4	%
Declared energy efficiency ratio or gas utilization efficiency / auxiliary energy factor for part load at given outdoor temperatures Tj			
Tj=+35°C	EERd or GUEc,bin / AEFc,bin	329.0	%
Tj=+30°C	EERd or GUEc,bin / AEFc,bin	526.0	%
Tj=+25°C	EERd or GUEc,bin / AEFc,bin	665.0	%
Tj=+20°C	EERd or GUEc,bin / AEFc,bin	2430.0	%
Crankcase heater mode		P _{CK}	0.082 kW
Standby mode		P _{SB}	0.082 kW
For air-to-air air conditioner: air flow-rate,outdoor measured		16800	m ³ /h
Contact details Mitsubishi heavy industries thermal systems,LTD			
** If Cdc is not determined by measurement then the default degradation coefficient air conditioners shall be 0,25.			
*** from 26 September 2018			
Where information relates to multi-split air conditioners,the test result and performance data be obtained on the basis of the performance of the outdoor unit, with a combination of indoor unit(s) recommended by the manufacturer or importer.			

Information to identify the model(s) to which the information relates :				FDC500KXZRE1			
Outdoor side heat exchanger of heat pump :				air			
Indoor side heat exchanger of heat pump :				air			
Indication if the heater is equipped with a supplementary heater :				No			
if applicable :				electric motor			
Parameters shall be declared for the average heating season , parameters for the warmer and colder heating seasons are optional.							
Item	Symbol	Value	Unit	Item	Symbol	Value	Unit
Rated heating capacity	Prated,h	50.0	kW	Seasonal space heating energy efficiency ηs,h		178.8	%
Declared heating capacity for part load at indoor temperature 20°C and outdoor temperature Tj				Declared coefficient of performance or gas utilization efficiency / auxiliary energy factor for part load at given outdoor temperatures Tj			
Tj=-7°C	Pdh	35.3	kW	Tj=-7°C	COPd or GUEh,bin / AEFh,bin	313.0	%
Tj=+2°C	Pdh	21.7	kW	Tj=+2°C	COPd or GUEh,bin / AEFh,bin	397.0	%
Tj=+7°C	Pdh	14.0	kW	Tj=+7°C	COPd or GUEh,bin / AEFh,bin	655.0	%
Tj=+12°C	Pdh	7.0	kW	Tj=+12°C	COPd or GUEh,bin / AEFh,bin	916.0	%
Tbiv=bivalent temperature	Pdh	40.1	kW	Tbiv=bivalent temperature	COPd or GUEh,bin / AEFh,bin	267.0	%
TOL=operation limit	Pdh	29.5	kW	TOL=operation limit	COPd or GUEh,bin / AEFh,bin	225.0	%
For air-to-water heat pumps : Tj=-15°C (if TOL < -20°C)	Pdh	-	kW	For air-to-water heat pumps: Tj=-15°C (if TOL < -20°C)	COPd or GUEh,bin / AEFh,bin	-	%
Bivalent temperature	Tbiv	-10.0	°C	For water-to-air heat pumps: Operation limit		-	°C
Degradation coefficient heat pumps**	Cdh	0.25	-	Ta temperature			
Power consumption in modes other than 'active mode'				Supplementary heater back-up heating capacity			
Off mode	POFF	0.082	kW	elbu		-	kW
Thermostat-off mode	PTD	0.082	kW	Type of energy input Standby mode	Psb	0.082	kW
Crankcase heater mode	PCK	0.082	kW				
Other items				For air-to-air heat pumps: air flow-rate,outdoor measured			
Capacity control		variable				15600	m3/h
Sound power level, outdoor measured	LWA	82.0	dB	For water-/brine-to-air heat pumps : Rated brine or water flow-rate, outdoor side heat exchanger		-	m3/h
Emissions of nitrogen oxides(if applicable)	NOx ***	-	mg/kWh fuel input GCV				
GWP of the refrigerant		2088	kg CO2eq (100years)				
Contact details		Mitsubishi heavy industries thermal systems,LTD					
** If Cdh is not determined by measurement then the default degradation coefficient air conditioners shall be 0,25.							
*** from 26 September 2018							
Where information relates to multi-split air conditioners,the test result and performance data be obtained on the basis of the performance of the outdoor unit, with a combination of indoor unit(s) recommended by the manufacturer or importer.							

Model(s) : FDC560KXZRE1			
Outdoor side heat exchanger of air conditioner :		air	
Indoor side heat exchanger of air conditioner :		air	
Type : vapour compression			
if applicable : electric motor			
Item	Symbol	Value	Unit
Rated cooling capacity	Prated,c	56.0	kW
Declared cooling capacity for part load at given outdoor temperatures Tj and indoor 27°C/19°C(dry/wet bulb)			
Tj=+35°C	Pdc	56.0	kW
Tj=+30°C	Pdc	41.0	kW
Tj=+25°C	Pdc	26.3	kW
Tj=+20°C	Pdc	11.7	kW
Degradation coefficient for air conditioners**	Cdc	0.25	-
Power consumption in other than 'active mode'			
Off mode	P _{OFF}	0.082	kW
Thermostat-off mode	P _{TO}	0.000	kW
Other items			
Capacity control		variable	
Sound power level, outdoor	L _{WA}	84.0	dB
If engine driven: Emissions of nitrogen oxides	NOx ***	-	mg/kWh fuel input GCV
GWP of the refrigerant		2088	kg CO _{2eq} (100years)
Seasonal space cooling energy efficiency ηs,c		247.2	%
Declared energy efficiency ratio or gas utilization efficiency / auxiliary energy factor for part load at given outdoor temperatures Tj			
Tj=+35°C	EERd or GUEc,bin / AEFc,bin	305.0	%
Tj=+30°C	EERd or GUEc,bin / AEFc,bin	486.0	%
Tj=+25°C	EERd or GUEc,bin / AEFc,bin	566.0	%
Tj=+20°C	EERd or GUEc,bin / AEFc,bin	1980.0	%
Crankcase heater mode		P _{CK}	0.082 kW
Standby mode		P _{SB}	0.082 kW
For air-to-air air conditioner: air flow-rate,outdoor measured		18600	m ³ /h
Contact details Mitsubishi heavy industries thermal systems,LTD			
** If Cdc is not determined by measurement then the default degradation coefficient air conditioners shall be 0,25.			
*** from 26 September 2018			
Where information relates to multi-split air conditioners,the test result and performance data be obtained on the basis of the performance of the outdoor unit, with a combination of indoor unit(s) recommended by the manufacturer or importer.			

Information to identify the model(s) to which the information relates :				FDC560KXZRE1			
Outdoor side heat exchanger of heat pump :				air			
Indoor side heat exchanger of heat pump :				air			
Indication if the heater is equipped with a supplementary heater :				No			
if applicable :				electric motor			
Parameters shall be declared for the average heating season , parameters for the warmer and colder heating seasons are optional.							
Item	Symbol	Value	Unit	Item	Symbol	Value	Unit
Rated heating capacity	Prated,h	56.0	kW	Seasonal space heating energy efficiency ηs,h		168.7	%
Declared heating capacity for part load at indoor temperature 20°C and outdoor temperature Tj				Declared coefficient of performance or gas utilization efficiency / auxiliary energy factor for part load at given outdoor temperatures Tj			
Tj=-7°C	Pdh	35.0	kW	Tj=-7°C	COPd or GUEh,bin / AEFh,bin	307.0	%
Tj=+2°C	Pdh	21.5	kW	Tj=+2°C	COPd or GUEh,bin / AEFh,bin	392.0	%
Tj=+7°C	Pdh	13.9	kW	Tj=+7°C	COPd or GUEh,bin / AEFh,bin	554.0	%
Tj=+12°C	Pdh	6.1	kW	Tj=+12°C	COPd or GUEh,bin / AEFh,bin	775.0	%
Tbiv=bivalent temperature	Pdh	39.7	kW	Tbiv=bivalent temperature	COPd or GUEh,bin / AEFh,bin	263.0	%
TOL=operation limit	Pdh	29.1	kW	TOL=operation limit	COPd or GUEh,bin / AEFh,bin	222.0	%
For air-to-water heat pumps : Tj=-15°C (if TOL < -20°C)	Pdh	-	kW	For air-to-water heat pumps: Tj=-15°C (if TOL < -20°C)	COPd or GUEh,bin / AEFh,bin	-	%
Bivalent temperature	Tbiv	-10.0	°C	For water-to-air heat pumps: Operation limit		-	°C
Degradation coefficient heat pumps**	Cdh	0.25	-	Ta temperature			
Power consumption in modes other than 'active mode'				Supplementary heater back-up heating capacity			
Off mode	P _{OFF}	0.082	kW	elbu		-	kW
Thermostat-off mode	P _{TO}	0.082	kW	Type of energy input Standby mode	P _{SB}	0.082	kW
Crankcase heater mode	P _{CK}	0.082	kW				
Other items				For air-to-air heat pumps: air flow-rate,outdoor measured			
Capacity control		variable				17400	m ³ /h
Sound power level, outdoor measured	L _{WA}	85.0	dB	For water-/brine-to-air heat pumps : Rated brine or water flow-rate, outdoor side heat exchanger		-	m ³ /h
Emissions of nitrogen oxides(if applicable)	NOx ***	-	mg/kWh fuel input GCV				
GWP of the refrigerant		2088	kg CO _{2eq} (100years)				
Contact details				Mitsubishi heavy industries thermal systems,LTD			
** If Cdh is not determined by measurement then the default degradation coefficient air conditioners shall be 0,25.							
*** from 26 September 2018							
Where information relates to multi-split air conditioners,the test result and performance data be obtained on the basis of the performance of the outdoor unit, with a combination of indoor unit(s) recommended by the manufacturer or importer.							

Model(s) : FDC615KXZRE1							
Outdoor side heat exchanger of air conditioner :				air			
Indoor side heat exchanger of air conditioner :				air			
Type : vapour compression							
if applicable : electric motor							
Item	Symbol	Value	Unit	Item	Symbol	Value	Unit
Rated cooling capacity	Prated,c	61.5	kW	Seasonal space cooling energy efficiency ηs,c		228.7	%
Declared cooling capacity for part load at given outdoor temperatures Tj and indoor 27°C/19°C(dry/wet bulb)				Declared energy efficiency ratio or gas utilization efficiency / auxiliary energy factor for part load at given outdoor temperatures Tj			
Tj=+35°C	Pdc	61.5	kW	Tj=+35°C	EERd or GUEc,bin / AEFc,bin	288.0	%
Tj=+30°C	Pdc	45.2	kW	Tj=+30°C	EERd or GUEc,bin / AEFc,bin	440.0	%
Tj=+25°C	Pdc	29.1	kW	Tj=+25°C	EERd or GUEc,bin / AEFc,bin	526.0	%
Tj=+20°C	Pdc	12.8	kW	Tj=+20°C	EERd or GUEc,bin / AEFc,bin	1780.0	%
Degradation coefficient for air conditioners**	Cdc	0.25	-				
Power consumption in other than 'active mode'							
Off mode	P _{OFF}	0.082	kW	Crankcase heater mode	P _{CK}	0.082	kW
Thermostat-off mode	P _{TO}	0.000	kW	Standby mode	P _{SB}	0.082	kW
Other items				For air-to-air air conditioner: air flow-rate,outdoor measured			
Capacity control		variable				18600	m ³ /h
Sound power level, outdoor	L _{WA}	84.0	dB				
If engine driven: Emissions of nitrogen oxides	NOx ***	-	mg/kWh fuel input GCV				
GWP of the refrigerant		2088	kg CO _{2eq} (100years)				
Contact details	Mitsubishi heavy industries thermal systems,LTD						
** If Cdc is not determined by measurement then the default degradation coefficient air conditioners shall be 0,25.							
*** from 26 September 2018							
Where information relates to multi-split air conditioners,the test result and performance data be obtained on the basis of the performance of the outdoor unit, with a combination of indoor unit(s) recommended by the manufacturer or importer.							

Information to identify the model(s) to which the information relates :				FDC615KXZRE1			
Outdoor side heat exchanger of heat pump :				air			
Indoor side heat exchanger of heat pump :				air			
Indication if the heater is equipped with a supplementary heater :				No			
if applicable :				electric motor			
Parameters shall be declared for the average heating season , parameters for the warmer and colder heating seasons are optional.							
Item	Symbol	Value	Unit	Item	Symbol	Value	Unit
Rated heating capacity	Prated,h	61.5	kW	Seasonal space heating energy efficiency ηs,h		170.8	%
Declared heating capacity for part load at indoor temperature 20°C and outdoor temperature Tj				Declared coefficient of performance or gas utilization efficiency / auxiliary energy factor for part load at given outdoor temperatures Tj			
Tj=-7°C	Pdh	35.1	kW	Tj=-7°C	COPd or GUEh,bin / AEFh,bin	310.0	%
Tj=+2°C	Pdh	21.7	kW	Tj=+2°C	COPd or GUEh,bin / AEFh,bin	394.0	%
Tj=+7°C	Pdh	14.0	kW	Tj=+7°C	COPd or GUEh,bin / AEFh,bin	567.0	%
Tj=+12°C	Pdh	6.2	kW	Tj=+12°C	COPd or GUEh,bin / AEFh,bin	795.0	%
Tbiv=bivalent temperature	Pdh	39.8	kW	Tbiv=bivalent temperature	COPd or GUEh,bin / AEFh,bin	268.0	%
TOL=operation limit	Pdh	29.2	kW	TOL=operation limit	COPd or GUEh,bin / AEFh,bin	222.0	%
For air-to-water heat pumps : Tj=-15°C (if TOL < -20°C)	Pdh	-	kW	For air-to-water heat pumps: Tj=-15°C (if TOL < -20°C)	COPd or GUEh,bin / AEFh,bin	-	%
Bivalent temperature	Tbiv	-10.0	°C	For water-to-air heat pumps: Operation limit		-	°C
Degradation coefficient heat pumps**	Cdh	0.25	-	Ta temperature			
Power consumption in modes other than 'active mode'				Supplementary heater back-up heating capacity			
Off mode	POFF	0.082	kW	elbu		-	kW
Thermostat-off mode	PTD	0.082	kW	Type of energy input Standby mode	Psb	0.082	kW
Crankcase heater mode	PCK	0.082	kW				
Other items				For air-to-air heat pumps: air flow-rate,outdoor measured			
Capacity control		variable				17400	m3/h
Sound power level, outdoor measured	LWA	85.0	dB	For water-/brine-to-air heat pumps : Rated brine or water flow-rate, outdoor side heat exchanger		-	m3/h
Emissions of nitrogen oxides(if applicable)	NOx ***	-	mg/kWh fuel input GCV				
GWP of the refrigerant		2088	kg CO2eq (100years)				
Contact details		Mitsubishi heavy industries thermal systems,LTD					
** If Cdh is not determined by measurement then the default degradation coefficient air conditioners shall be 0,25.							
*** from 26 September 2018							
Where information relates to multi-split air conditioners,the test result and performance data be obtained on the basis of the performance of the outdoor unit, with a combination of indoor unit(s) recommended by the manufacturer or importer.							

Model(s) : FDC670KXZRE1							
Outdoor side heat exchanger of air conditioner : air							
Indoor side heat exchanger of air conditioner : air							
Type : vapour compression							
if applicable : electric motor							
Item	Symbol	Value	Unit	Item	Symbol	Value	Unit
Rated cooling capacity	Prated,c	67.0	kW	Seasonal space cooling energy efficiency ηs,c		228.3	%
Declared cooling capacity for part load at given outdoor temperatures Tj and indoor 27°C/19°C(dry/wet bulb)				Declared energy efficiency ratio or gas utilization efficiency / auxiliary energy factor for part load at given outdoor temperatures Tj			
Tj=+35°C	Pdc	67.0	kW	Tj=+35°C	EERd or GUEc,bin / AEFc,bin	262.0	%
Tj=+30°C	Pdc	49.2	kW	Tj=+30°C	EERd or GUEc,bin / AEFc,bin	428.0	%
Tj=+25°C	Pdc	31.7	kW	Tj=+25°C	EERd or GUEc,bin / AEFc,bin	538.0	%
Tj=+20°C	Pdc	13.9	kW	Tj=+20°C	EERd or GUEc,bin / AEFc,bin	1880.0	%
Degradation coefficient for air conditioners**	Cdc	0.25	-				
Power consumption in other than 'active mode'							
Off mode	P _{OFF}	0.082	kW	Crankcase heater mode	P _{CK}	0.082	kW
Thermostat-off mode	P _{TO}	0.000	kW	Standby mode	P _{SB}	0.082	kW
Other items				For air-to-air air conditioner: air flow-rate,outdoor measured			
Capacity control		variable				18600	m3/h
Sound power level, outdoor	L _{WA}	84.0	dB				
If engine driven: Emissions of nitrogen oxides	NOx ***	-	mg/kWh fuel input GCV				
GWP of the refrigerant		2088	kg CO _{2eq} (100years)				
Contact details	Mitsubishi heavy industries thermal systems,LTD						
** If Cdc is not determined by measurement then the default degradation coefficient air conditioners shall be 0,25.							
*** from 26 September 2018							
Where information relates to multi-split air conditioners,the test result and performance data be obtained on the basis of the performance of the outdoor unit, with a combination of indoor unit(s) recommended by the manufacturer or importer.							

Information to identify the model(s) to which the information relates :				FDC670KXZRE1			
Outdoor side heat exchanger of heat pump :				air			
Indoor side heat exchanger of heat pump :				air			
Indication if the heater is equipped with a supplementary heater :				No			
if applicable :				electric motor			
Parameters shall be declared for the average heating season , parameters for the warmer and colder heating seasons are optional.							
Item	Symbol	Value	Unit	Item	Symbol	Value	Unit
Rated heating capacity	Prated,h	63.0	kW	Seasonal space heating energy efficiency ηs,h		183.5	%
Declared heating capacity for part load at indoor temperature 20°C and outdoor temperature Tj				Declared coefficient of performance or gas utilization efficiency / auxiliary energy factor for part load at given outdoor temperatures Tj			
Tj=-7°C	Pdh	35.8	kW	Tj=-7°C	COPd or GUEh,bin / AEFh,bin	325.0	%
Tj=+2°C	Pdh	21.9	kW	Tj=+2°C	COPd or GUEh,bin / AEFh,bin	426.0	%
Tj=+7°C	Pdh	14.3	kW	Tj=+7°C	COPd or GUEh,bin / AEFh,bin	614.0	%
Tj=+12°C	Pdh	6.4	kW	Tj=+12°C	COPd or GUEh,bin / AEFh,bin	841.0	%
Tbiv=bivalent temperature	Pdh	40.5	kW	Tbiv=bivalent temperature	COPd or GUEh,bin / AEFh,bin	279.0	%
TOL=operation limit	Pdh	29.9	kW	TOL=operation limit	COPd or GUEh,bin / AEFh,bin	232.0	%
For air-to-water heat pumps : Tj=-15°C (if TOL < -20°C)	Pdh	-	kW	For air-to-water heat pumps: Tj=-15°C (if TOL < -20°C)	COPd or GUEh,bin / AEFh,bin	-	%
Bivalent temperature	Tbiv	-10.0	°C	For water-to-air heat pumps: Operation limit		-	°C
Degradation coefficient heat pumps**	Cdh	0.25	-	Ta temperature			
Power consumption in modes other than 'active mode'				Supplementary heater back-up heating capacity			
Off mode	POFF	0.082	kW	elbu		-	kW
Thermostat-off mode	PTD	0.082	kW	Type of energy input Standby mode	Psb	0.082	kW
Crankcase heater mode	PCK	0.082	kW				
Other items				For air-to-air heat pumps: air flow-rate,outdoor measured			
Capacity control		variable				17400	m3/h
Sound power level, outdoor measured	LWA	85.0	dB	For water-/brine-to-air heat pumps : Rated brine or water flow-rate, outdoor side heat exchanger		-	m3/h
Emissions of nitrogen oxides(if applicable)	NOx ***	-	mg/kWh fuel input GCV				
GWP of the refrigerant		2088	kg CO2eq (100years)				
Contact details		Mitsubishi heavy industries thermal systems,LTD					
** If Cdh is not determined by measurement then the default degradation coefficient air conditioners shall be 0,25.							
*** from 26 September 2018							
Where information relates to multi-split air conditioners,the test result and performance data be obtained on the basis of the performance of the outdoor unit, with a combination of indoor unit(s) recommended by the manufacturer or importer.							

7.2 Indoor unit

Model(s) : FDT28KXZE1							
Item	Symbol	Value	Unit	Item	Symbol	Value	Unit
Cooling capacity (sensible)	$P_{rated,c}$	2.7	kW	Total electric power input	P_{elec}	0.020	kW
Cooling capacity (latent)	$P_{rated,c}$	0.1	kW	Sound power level (per speed setting,if applicable)	L_{WA}	49.0	dB
Heating capacity	$P_{rated,h}$	3.2	kW				
Contact details	Mitsubishi heavy industries thermal systems,LTD						

Model(s) : FDT36KXZE1							
Item	Symbol	Value	Unit	Item	Symbol	Value	Unit
Cooling capacity (sensible)	$P_{rated,c}$	3.4	kW	Total electric power input	P_{elec}	0.030	kW
Cooling capacity (latent)	$P_{rated,c}$	0.2	kW	Sound power level (per speed setting,if applicable)	L_{WA}	49.0	dB
Heating capacity	$P_{rated,h}$	4.0	kW				
Contact details	Mitsubishi heavy industries thermal systems,LTD						

Model(s) : FDT45KXZE1							
Item	Symbol	Value	Unit	Item	Symbol	Value	Unit
Cooling capacity (sensible)	$P_{rated,c}$	3.8	kW	Total electric power input	P_{elec}	0.030	kW
Cooling capacity (latent)	$P_{rated,c}$	0.7	kW	Sound power level (per speed setting,if applicable)	L_{WA}	50.0	dB
Heating capacity	$P_{rated,h}$	5.0	kW				
Contact details	Mitsubishi heavy industries thermal systems,LTD						

Model(s) : FDT56KXZE1							
Item	Symbol	Value	Unit	Item	Symbol	Value	Unit
Cooling capacity (sensible)	$P_{rated,c}$	4.7	kW	Total electric power input	P_{elec}	0.040	kW
Cooling capacity (latent)	$P_{rated,c}$	0.9	kW	Sound power level (per speed setting,if applicable)	L_{WA}	55.0	dB
Heating capacity	$P_{rated,h}$	6.3	kW				
Contact details	Mitsubishi heavy industries thermal systems,LTD						

Model(s) : FDT71KXZE1							
Item	Symbol	Value	Unit	Item	Symbol	Value	Unit
Cooling capacity (sensible)	$P_{rated,c}$	6.2	kW	Total electric power input	P_{elec}	0.080	kW
Cooling capacity (latent)	$P_{rated,c}$	0.9	kW	Sound power level (per speed setting,if applicable)	L_{WA}	62.0	dB
Heating capacity	$P_{rated,h}$	8.0	kW				
Contact details	Mitsubishi heavy industries thermal systems,LTD						

Model(s) : FDT90KXZE1							
Item	Symbol	Value	Unit	Item	Symbol	Value	Unit
Cooling capacity (sensible)	$P_{rated,c}$	7.9	kW	Total electric power input	P_{elec}	0.130	kW
Cooling capacity (latent)	$P_{rated,c}$	1.1	kW	Sound power level (per speed setting,if applicable)	L_{WA}	65.0	dB
Heating capacity	$P_{rated,h}$	10.0	kW				
Contact details	Mitsubishi heavy industries thermal systems,LTD						

Model(s) : FDT112KXZE1							
Item	Symbol	Value	Unit	Item	Symbol	Value	Unit
Cooling capacity (sensible)	$P_{rated,c}$	9.4	kW	Total electric power input	P_{elec}	0.140	kW
Cooling capacity (latent)	$P_{rated,c}$	1.8	kW	Sound power level (per speed setting,if applicable)	L_{WA}	66.0	dB
Heating capacity	$P_{rated,h}$	12.5	kW				
Contact details	Mitsubishi heavy industries thermal systems,LTD						

Model(s) : FDT140KXZE1							
Item	Symbol	Value	Unit	Item	Symbol	Value	Unit
Cooling capacity (sensible)	$P_{rated,c}$	10.7	kW	Total electric power input	P_{elec}	0.140	kW
Cooling capacity (latent)	$P_{rated,c}$	3.3	kW	Sound power level (per speed setting,if applicable)	L_{WA}	66.0	dB
Heating capacity	$P_{rated,h}$	16.0	kW				
Contact details	Mitsubishi heavy industries thermal systems,LTD						

Model(s) : FDT160KXZE1							
Item	Symbol	Value	Unit	Item	Symbol	Value	Unit
Cooling capacity (sensible)	$P_{rated,c}$	11.5	kW	Total electric power input	P_{elec}	0.140	kW
Cooling capacity (latent)	$P_{rated,c}$	4.5	kW	Sound power level (per speed setting,if applicable)	L_{WA}	66.0	dB
Heating capacity	$P_{rated,h}$	18.0	kW				
Contact details	Mitsubishi heavy industries thermal systems,LTD						

Model(s) : FDUM22KXE6F							
Item	Symbol	Value	Unit	Item	Symbol	Value	Unit
Cooling capacity (sensible)	$P_{rated,c}$	2.1	kW	Total electric power input	P_{elec}	0.100	kW
Cooling capacity (latent)	$P_{rated,c}$	0.1	kW	Sound power level (per speed setting,if applicable)	L_{WA}	60.0	dB
Heating capacity	$P_{rated,h}$	2.5	kW				
Contact details	Mitsubishi heavy industries thermal systems,LTD						

Model(s) : FDUM28KXE6F							
Item	Symbol	Value	Unit	Item	Symbol	Value	Unit
Cooling capacity (sensible)	$P_{rated,c}$	2.7	kW	Total electric power input	P_{elec}	0.100	kW
Cooling capacity (latent)	$P_{rated,c}$	0.1	kW	Sound power level (per speed setting,if applicable)	L_{WA}	60.0	dB
Heating capacity	$P_{rated,h}$	3.2	kW				
Contact details	Mitsubishi heavy industries thermal systems,LTD						

Model(s) : FDUM36KXE6F							
Item	Symbol	Value	Unit	Item	Symbol	Value	Unit
Cooling capacity (sensible)	$P_{rated,c}$	3.3	kW	Total electric power input	P_{elec}	0.100	kW
Cooling capacity (latent)	$P_{rated,c}$	0.3	kW	Sound power level (per speed setting,if applicable)	L_{WA}	60.0	dB
Heating capacity	$P_{rated,h}$	4.0	kW				
Contact details	Mitsubishi heavy industries thermal systems,LTD						

Model(s) : FDUM45KXE6F							
Item	Symbol	Value	Unit	Item	Symbol	Value	Unit
Cooling capacity (sensible)	$P_{rated,c}$	3.7	kW	Total electric power input	P_{elec}	0.100	kW
Cooling capacity (latent)	$P_{rated,c}$	0.8	kW	Sound power level (per speed setting,if applicable)	L_{WA}	60.0	dB
Heating capacity	$P_{rated,h}$	5.0	kW				
Contact details	Mitsubishi heavy industries thermal systems,LTD						

Model(s) : FDUM56KXE6F							
Item	Symbol	Value	Unit	Item	Symbol	Value	Unit
Cooling capacity (sensible)	$P_{rated,c}$	4.1	kW	Total electric power input	P_{elec}	0.100	kW
Cooling capacity (latent)	$P_{rated,c}$	1.5	kW	Sound power level (per speed setting,if applicable)	L_{WA}	60.0	dB
Heating capacity	$P_{rated,h}$	6.3	kW				
Contact details	Mitsubishi heavy industries thermal systems,LTD						

Model(s) : FDUM71KXE6F							
Item	Symbol	Value	Unit	Item	Symbol	Value	Unit
Cooling capacity (sensible)	$P_{rated,c}$	6.0	kW	Total electric power input	P_{elec}	0.200	kW
Cooling capacity (latent)	$P_{rated,c}$	1.1	kW	Sound power level (per speed setting,if applicable)	L_{WA}	65.0	dB
Heating capacity	$P_{rated,h}$	8.0	kW				
Contact details	Mitsubishi heavy industries thermal systems,LTD						

Model(s) : FDUM90KXE6F							
Item	Symbol	Value	Unit	Item	Symbol	Value	Unit
Cooling capacity (sensible)	$P_{rated,c}$	6.7	kW	Total electric power input	P_{elec}	0.200	kW
Cooling capacity (latent)	$P_{rated,c}$	2.3	kW	Sound power level (per speed setting,if applicable)	L_{WA}	65.0	dB
Heating capacity	$P_{rated,h}$	10.0	kW				
Contact details	Mitsubishi heavy industries thermal systems,LTD						

Model(s) : FDUM112KXE6F							
Item	Symbol	Value	Unit	Item	Symbol	Value	Unit
Cooling capacity (sensible)	$P_{rated,c}$	8.6	kW	Total electric power input	P_{elec}	0.290	kW
Cooling capacity (latent)	$P_{rated,c}$	2.6	kW	Sound power level (per speed setting,if applicable)	L_{WA}	67.0	dB
Heating capacity	$P_{rated,h}$	12.5	kW				
Contact details	Mitsubishi heavy industries thermal systems,LTD						

Model(s) : FDUM140KXE6F							
Item	Symbol	Value	Unit	Item	Symbol	Value	Unit
Cooling capacity (sensible)	$P_{rated,c}$	11.2	kW	Total electric power input	P_{elec}	0.330	kW
Cooling capacity (latent)	$P_{rated,c}$	2.8	kW	Sound power level (per speed setting,if applicable)	L_{WA}	72.0	dB
Heating capacity	$P_{rated,h}$	16.0	kW				
Contact details	Mitsubishi heavy industries thermal systems,LTD						

Model(s) : FDUM160KXE6F							
Item	Symbol	Value	Unit	Item	Symbol	Value	Unit
Cooling capacity (sensible)	$P_{rated,c}$	12.4	kW	Total electric power input	P_{elec}	0.450	kW
Cooling capacity (latent)	$P_{rated,c}$	3.6	kW	Sound power level (per speed setting,if applicable)	L_{WA}	76.0	dB
Heating capacity	$P_{rated,h}$	18.0	kW				
Contact details	Mitsubishi heavy industries thermal systems,LTD						

Model(s) : FDU224KXZE1							
Item	Symbol	Value	Unit	Item	Symbol	Value	Unit
Cooling capacity (sensible)	$P_{rated,c}$	19.7	kW	Total electric power input	P_{elec}	1.180	kW
Cooling capacity (latent)	$P_{rated,c}$	2.7	kW	Sound power level (per speed setting,if applicable)	L_{WA}	75.0	dB
Heating capacity	$P_{rated,h}$	25.0	kW				
Contact details	Mitsubishi heavy industries thermal systems,LTD						

Model(s) : FDU280KXZE1							
Item	Symbol	Value	Unit	Item	Symbol	Value	Unit
Cooling capacity (sensible)	$P_{rated,c}$	21.9	kW	Total electric power input	P_{elec}	1.180	kW
Cooling capacity (latent)	$P_{rated,c}$	6.1	kW	Sound power level (per speed setting,if applicable)	L_{WA}	75.0	dB
Heating capacity	$P_{rated,h}$	31.5	kW				
Contact details	Mitsubishi heavy industries thermal systems,LTD						

Model(s) : FDK15KXZE1						
Item	Symbol	Value	Unit	Item	Symbol	Value Unit
Cooling capacity (sensible)	$P_{rated,c}$	1.2	kW	Total electric power input	P_{elec}	0.020 kW
Cooling capacity (latent)	$P_{rated,c}$	0.3	kW	Sound power level (per speed setting,if applicable)	L_{WA}	54.0 dB
Heating capacity	$P_{rated,h}$	1.7	kW			
Contact details	Mitsubishi heavy industries thermal systems,LTD					

Model(s) : FDK22KXZE1						
Item	Symbol	Value	Unit	Item	Symbol	Value Unit
Cooling capacity (sensible)	$P_{rated,c}$	1.8	kW	Total electric power input	P_{elec}	0.020 kW
Cooling capacity (latent)	$P_{rated,c}$	0.4	kW	Sound power level (per speed setting,if applicable)	L_{WA}	55.0 dB
Heating capacity	$P_{rated,h}$	2.5	kW			
Contact details	Mitsubishi heavy industries thermal systems,LTD					

Model(s) : FDK28KXZE1						
Item	Symbol	Value	Unit	Item	Symbol	Value Unit
Cooling capacity (sensible)	$P_{rated,c}$	2.2	kW	Total electric power input	P_{elec}	0.020 kW
Cooling capacity (latent)	$P_{rated,c}$	0.6	kW	Sound power level (per speed setting,if applicable)	L_{WA}	55.0 dB
Heating capacity	$P_{rated,h}$	3.2	kW			
Contact details	Mitsubishi heavy industries thermal systems,LTD					

Model(s) : FDK36KXZE1						
Item	Symbol	Value	Unit	Item	Symbol	Value Unit
Cooling capacity (sensible)	$P_{rated,c}$	2.8	kW	Total electric power input	P_{elec}	0.030 kW
Cooling capacity (latent)	$P_{rated,c}$	0.8	kW	Sound power level (per speed setting,if applicable)	L_{WA}	58.0 dB
Heating capacity	$P_{rated,h}$	4.0	kW			
Contact details	Mitsubishi heavy industries thermal systems,LTD					

Model(s) : FDK45KXZE1						
Item	Symbol	Value	Unit	Item	Symbol	Value Unit
Cooling capacity (sensible)	$P_{rated,c}$	3.3	kW	Total electric power input	P_{elec}	0.030 kW
Cooling capacity (latent)	$P_{rated,c}$	1.2	kW	Sound power level (per speed setting,if applicable)	L_{WA}	58.0 dB
Heating capacity	$P_{rated,h}$	5.0	kW			
Contact details	Mitsubishi heavy industries thermal systems,LTD					

Model(s) : FDK56KXZE1						
Item	Symbol	Value	Unit	Item	Symbol	Value Unit
Cooling capacity (sensible)	$P_{rated,c}$	3.9	kW	Total electric power input	P_{elec}	0.030 kW
Cooling capacity (latent)	$P_{rated,c}$	1.7	kW	Sound power level (per speed setting,if applicable)	L_{WA}	58.0 dB
Heating capacity	$P_{rated,h}$	6.3	kW			
Contact details	Mitsubishi heavy industries thermal systems,LTD					

Model(s) : FDK71KXZE1						
Item	Symbol	Value	Unit	Item	Symbol	Value Unit
Cooling capacity (sensible)	$P_{rated,c}$	5.4	kW	Total electric power input	P_{elec}	0.040 kW
Cooling capacity (latent)	$P_{rated,c}$	1.7	kW	Sound power level (per speed setting,if applicable)	L_{WA}	59.0 dB
Heating capacity	$P_{rated,h}$	8.0	kW			
Contact details	Mitsubishi heavy industries thermal systems,LTD					

Model(s) : FDK90KXZE1							
Item	Symbol	Value	Unit	Item	Symbol	Value	Unit
Cooling capacity (sensible)	$P_{rated,c}$	6.5	kW	Total electric power input	P_{elec}	0.050	kW
Cooling capacity (latent)	$P_{rated,c}$	2.5	kW	Sound power level (per speed setting,if applicable)	L_{WA}	61.0	dB
Heating capacity	$P_{rated,h}$	10.0	kW				
Contact details	Mitsubishi heavy industries thermal systems,LTD						

Model(s) : FDTC15KXE6F							
Item	Symbol	Value	Unit	Item	Symbol	Value	Unit
Cooling capacity (sensible)	$P_{rated,c}$	1.3	kW	Total electric power input	P_{elec}	0.020	kW
Cooling capacity (latent)	$P_{rated,c}$	0.2	kW	Sound power level (per speed setting,if applicable)	L_{WA}	56.0	dB
Heating capacity	$P_{rated,h}$	1.7	kW				
Contact details	Mitsubishi heavy industries thermal systems,LTD						

Model(s) : FDTC22KXE6F							
Item	Symbol	Value	Unit	Item	Symbol	Value	Unit
Cooling capacity (sensible)	$P_{rated,c}$	2.1	kW	Total electric power input	P_{elec}	0.030	kW
Cooling capacity (latent)	$P_{rated,c}$	0.1	kW	Sound power level (per speed setting,if applicable)	L_{WA}	56.0	dB
Heating capacity	$P_{rated,h}$	2.5	kW				
Contact details	Mitsubishi heavy industries thermal systems,LTD						

Model(s) : FDTC28KXE6F							
Item	Symbol	Value	Unit	Item	Symbol	Value	Unit
Cooling capacity (sensible)	$P_{rated,c}$	2.4	kW	Total electric power input	P_{elec}	0.030	kW
Cooling capacity (latent)	$P_{rated,c}$	0.4	kW	Sound power level (per speed setting,if applicable)	L_{WA}	56.0	dB
Heating capacity	$P_{rated,h}$	3.2	kW				
Contact details	Mitsubishi heavy industries thermal systems,LTD						

Model(s) : FDTC36KXE6F							
Item	Symbol	Value	Unit	Item	Symbol	Value	Unit
Cooling capacity (sensible)	$P_{rated,c}$	3.2	kW	Total electric power input	P_{elec}	0.030	kW
Cooling capacity (latent)	$P_{rated,c}$	0.4	kW	Sound power level (per speed setting,if applicable)	L_{WA}	58.0	dB
Heating capacity	$P_{rated,h}$	4.0	kW				
Contact details	Mitsubishi heavy industries thermal systems,LTD						

Model(s) : FDTC45KXE6F							
Item	Symbol	Value	Unit	Item	Symbol	Value	Unit
Cooling capacity (sensible)	$P_{rated,c}$	3.8	kW	Total electric power input	P_{elec}	0.050	kW
Cooling capacity (latent)	$P_{rated,c}$	0.7	kW	Sound power level (per speed setting,if applicable)	L_{WA}	60.0	dB
Heating capacity	$P_{rated,h}$	5.0	kW				
Contact details	Mitsubishi heavy industries thermal systems,LTD						

Model(s) : FDTC56KXE6F							
Item	Symbol	Value	Unit	Item	Symbol	Value	Unit
Cooling capacity (sensible)	$P_{rated,c}$	4.4	kW	Total electric power input	P_{elec}	0.050	kW
Cooling capacity (latent)	$P_{rated,c}$	1.2	kW	Sound power level (per speed setting,if applicable)	L_{WA}	60.0	dB
Heating capacity	$P_{rated,h}$	6.3	kW				
Contact details	Mitsubishi heavy industries thermal systems,LTD						

Model(s) : FDTW28KXE6F							
Item	Symbol	Value	Unit	Item	Symbol	Value	Unit
Cooling capacity (sensible)	$P_{rated,c}$	2.3	kW	Total electric power input	P_{elec}	0.090	kW
Cooling capacity (latent)	$P_{rated,c}$	0.5	kW	Sound power level (per speed setting,if applicable)	L_{WA}	58.0	dB
Heating capacity	$P_{rated,h}$	3.2	kW				
Contact details	Mitsubishi heavy industries thermal systems,LTD						

Model(s) : FDTW45KXE6F							
Item	Symbol	Value	Unit	Item	Symbol	Value	Unit
Cooling capacity (sensible)	$P_{rated,c}$	3.4	kW	Total electric power input	P_{elec}	0.100	kW
Cooling capacity (latent)	$P_{rated,c}$	1.1	kW	Sound power level (per speed setting,if applicable)	L_{WA}	58.0	dB
Heating capacity	$P_{rated,h}$	5.0	kW				
Contact details	Mitsubishi heavy industries thermal systems,LTD						

Model(s) : FDTW56KXE6F							
Item	Symbol	Value	Unit	Item	Symbol	Value	Unit
Cooling capacity (sensible)	$P_{rated,c}$	4.0	kW	Total electric power input	P_{elec}	0.100	kW
Cooling capacity (latent)	$P_{rated,c}$	1.6	kW	Sound power level (per speed setting,if applicable)	L_{WA}	58.0	dB
Heating capacity	$P_{rated,h}$	6.3	kW				
Contact details	Mitsubishi heavy industries thermal systems,LTD						

Model(s) : FDTW71KXE6F							
Item	Symbol	Value	Unit	Item	Symbol	Value	Unit
Cooling capacity (sensible)	$P_{rated,c}$	4.8	kW	Total electric power input	P_{elec}	0.140	kW
Cooling capacity (latent)	$P_{rated,c}$	2.3	kW	Sound power level (per speed setting,if applicable)	L_{WA}	58.0	dB
Heating capacity	$P_{rated,h}$	8.0	kW				
Contact details	Mitsubishi heavy industries thermal systems,LTD						

Model(s) : FDTW90KXE6F							
Item	Symbol	Value	Unit	Item	Symbol	Value	Unit
Cooling capacity (sensible)	$P_{rated,c}$	6.8	kW	Total electric power input	P_{elec}	0.190	kW
Cooling capacity (latent)	$P_{rated,c}$	2.2	kW	Sound power level (per speed setting,if applicable)	L_{WA}	65.0	dB
Heating capacity	$P_{rated,h}$	10.0	kW				
Contact details	Mitsubishi heavy industries thermal systems,LTD						

Model(s) : FDTW112KXE6F							
Item	Symbol	Value	Unit	Item	Symbol	Value	Unit
Cooling capacity (sensible)	$P_{rated,c}$	8.1	kW	Total electric power input	P_{elec}	0.190	kW
Cooling capacity (latent)	$P_{rated,c}$	3.1	kW	Sound power level (per speed setting,if applicable)	L_{WA}	65.0	dB
Heating capacity	$P_{rated,h}$	12.5	kW				
Contact details	Mitsubishi heavy industries thermal systems,LTD						

Model(s) : FDTW140KXE6F							
Item	Symbol	Value	Unit	Item	Symbol	Value	Unit
Cooling capacity (sensible)	$P_{rated,c}$	9.9	kW	Total electric power input	P_{elec}	0.190	kW
Cooling capacity (latent)	$P_{rated,c}$	4.1	kW	Sound power level (per speed setting,if applicable)	L_{WA}	65.0	dB
Heating capacity	$P_{rated,h}$	16.0	kW				
Contact details	Mitsubishi heavy industries thermal systems,LTD						

Model(s) : FDTS45KXE6F							
Item	Symbol	Value	Unit	Item	Symbol	Value	Unit
Cooling capacity (sensible)	$P_{rated,c}$	3.3	kW	Total electric power input	P_{elec}	0.040	kW
Cooling capacity (latent)	$P_{rated,c}$	1.2	kW	Sound power level (per speed setting,if applicable)	L_{WA}	60.0	dB
Heating capacity	$P_{rated,h}$	5.0	kW				
Contact details	Mitsubishi heavy industries thermal systems,LTD						

Model(s) : FDTS71KXE6F							
Item	Symbol	Value	Unit	Item	Symbol	Value	Unit
Cooling capacity (sensible)	$P_{rated,c}$	5.0	kW	Total electric power input	P_{elec}	0.090	kW
Cooling capacity (latent)	$P_{rated,c}$	2.1	kW	Sound power level (per speed setting,if applicable)	L_{WA}	61.0	dB
Heating capacity	$P_{rated,h}$	8.0	kW				
Contact details	Mitsubishi heavy industries thermal systems,LTD						

Model(s) : FDTQ22KXE6F							
Item	Symbol	Value	Unit	Item	Symbol	Value	Unit
Cooling capacity (sensible)	$P_{rated,c}$	1.8	kW	Total electric power input	P_{elec}	0.060	kW
Cooling capacity (latent)	$P_{rated,c}$	0.4	kW	Sound power level (per speed setting,if applicable)	L_{WA}	60.0	dB
Heating capacity	$P_{rated,h}$	2.5	kW				
Contact details	Mitsubishi heavy industries thermal systems,LTD						

Model(s) : FDTQ28KXE6F							
Item	Symbol	Value	Unit	Item	Symbol	Value	Unit
Cooling capacity (sensible)	$P_{rated,c}$	2.1	kW	Total electric power input	P_{elec}	0.060	kW
Cooling capacity (latent)	$P_{rated,c}$	0.7	kW	Sound power level (per speed setting,if applicable)	L_{WA}	60.0	dB
Heating capacity	$P_{rated,h}$	3.2	kW				
Contact details	Mitsubishi heavy industries thermal systems,LTD						

Model(s) : FDTQ36KXE6F							
Item	Symbol	Value	Unit	Item	Symbol	Value	Unit
Cooling capacity (sensible)	$P_{rated,c}$	2.5	kW	Total electric power input	P_{elec}	0.060	kW
Cooling capacity (latent)	$P_{rated,c}$	1.1	kW	Sound power level (per speed setting,if applicable)	L_{WA}	60.0	dB
Heating capacity	$P_{rated,h}$	4.0	kW				
Contact details	Mitsubishi heavy industries thermal systems,LTD						

Model(s) : FDFL71KXE6F							
Item	Symbol	Value	Unit	Item	Symbol	Value	Unit
Cooling capacity (sensible)	$P_{rated,c}$	5.3	kW	Total electric power input	P_{elec}	0.100	kW
Cooling capacity (latent)	$P_{rated,c}$	1.8	kW	Sound power level (per speed setting,if applicable)	L_{WA}	62.0	dB
Heating capacity	$P_{rated,h}$	8.0	kW				
Contact details	Mitsubishi heavy industries thermal systems,LTD						

Model(s) : FDFU28KXE6F							
Item	Symbol	Value	Unit	Item	Symbol	Value	Unit
Cooling capacity (sensible)	$P_{rated,c}$	2.7	kW	Total electric power input	P_{elec}	0.100	kW
Cooling capacity (latent)	$P_{rated,c}$	0.1	kW	Sound power level (per speed setting,if applicable)	L_{WA}	58.0	dB
Heating capacity	$P_{rated,h}$	3.2	kW				
Contact details	Mitsubishi heavy industries thermal systems,LTD						

Model(s) : FDFU45KXE6F							
Item	Symbol	Value	Unit	Item	Symbol	Value	Unit
Cooling capacity (sensible)	$P_{rated,c}$	3.8	kW	Total electric power input	P_{elec}	0.100	kW
Cooling capacity (latent)	$P_{rated,c}$	0.7	kW	Sound power level (per speed setting,if applicable)	L_{WA}	60.0	dB
Heating capacity	$P_{rated,h}$	5.0	kW				
Contact details	Mitsubishi heavy industries thermal systems,LTD						

Model(s) : FDFU56KXE6F							
Item	Symbol	Value	Unit	Item	Symbol	Value	Unit
Cooling capacity (sensible)	$P_{rated,c}$	4.2	kW	Total electric power input	P_{elec}	0.100	kW
Cooling capacity (latent)	$P_{rated,c}$	1.4	kW	Sound power level (per speed setting,if applicable)	L_{WA}	60.0	dB
Heating capacity	$P_{rated,h}$	6.3	kW				
Contact details	Mitsubishi heavy industries thermal systems,LTD						

Model(s) : FDFU71KXE6F							
Item	Symbol	Value	Unit	Item	Symbol	Value	Unit
Cooling capacity (sensible)	$P_{rated,c}$	5.3	kW	Total electric power input	P_{elec}	0.100	kW
Cooling capacity (latent)	$P_{rated,c}$	1.8	kW	Sound power level (per speed setting,if applicable)	L_{WA}	60.0	dB
Heating capacity	$P_{rated,h}$	8.0	kW				
Contact details	Mitsubishi heavy industries thermal systems,LTD						

Model(s) : FDU45KXE6F							
Item	Symbol	Value	Unit	Item	Symbol	Value	Unit
Cooling capacity (sensible)	$P_{rated,c}$	3.7	kW	Total electric power input	P_{elec}	0.100	kW
Cooling capacity (latent)	$P_{rated,c}$	0.8	kW	Sound power level (per speed setting,if applicable)	L_{WA}	60.0	dB
Heating capacity	$P_{rated,h}$	5.0	kW				
Contact details	Mitsubishi heavy industries thermal systems,LTD						

Model(s) : FDU56KXE6F							
Item	Symbol	Value	Unit	Item	Symbol	Value	Unit
Cooling capacity (sensible)	$P_{rated,c}$	4.1	kW	Total electric power input	P_{elec}	0.100	kW
Cooling capacity (latent)	$P_{rated,c}$	1.5	kW	Sound power level (per speed setting,if applicable)	L_{WA}	60.0	dB
Heating capacity	$P_{rated,h}$	6.3	kW				
Contact details	Mitsubishi heavy industries thermal systems,LTD						

Model(s) : FDU71KXE6F							
Item	Symbol	Value	Unit	Item	Symbol	Value	Unit
Cooling capacity (sensible)	$P_{rated,c}$	6.0	kW	Total electric power input	P_{elec}	0.250	kW
Cooling capacity (latent)	$P_{rated,c}$	1.1	kW	Sound power level (per speed setting,if applicable)	L_{WA}	65.0	dB
Heating capacity	$P_{rated,h}$	8.0	kW				
Contact details	Mitsubishi heavy industries thermal systems,LTD						

Model(s) : FDU90KXE6F							
Item	Symbol	Value	Unit	Item	Symbol	Value	Unit
Cooling capacity (sensible)	$P_{rated,c}$	6.7	kW	Total electric power input	P_{elec}	0.250	kW
Cooling capacity (latent)	$P_{rated,c}$	2.3	kW	Sound power level (per speed setting,if applicable)	L_{WA}	65.0	dB
Heating capacity	$P_{rated,h}$	10.0	kW				
Contact details	Mitsubishi heavy industries thermal systems,LTD						

Model(s) : FDU112KXE6F							
Item	Symbol	Value	Unit	Item	Symbol	Value	Unit
Cooling capacity (sensible)	$P_{rated,c}$	8.6	kW	Total electric power input	P_{elec}	0.320	kW
Cooling capacity (latent)	$P_{rated,c}$	2.6	kW	Sound power level (per speed setting,if applicable)	L_{WA}	67.0	dB
Heating capacity	$P_{rated,h}$	12.5	kW				
Contact details	Mitsubishi heavy industries thermal systems,LTD						

Model(s) : FDU140KXE6F							
Item	Symbol	Value	Unit	Item	Symbol	Value	Unit
Cooling capacity (sensible)	$P_{rated,c}$	11.2	kW	Total electric power input	P_{elec}	0.360	kW
Cooling capacity (latent)	$P_{rated,c}$	2.8	kW	Sound power level (per speed setting,if applicable)	L_{WA}	72.0	dB
Heating capacity	$P_{rated,h}$	16.0	kW				
Contact details	Mitsubishi heavy industries thermal systems,LTD						

Model(s) : FDU160KXE6F							
Item	Symbol	Value	Unit	Item	Symbol	Value	Unit
Cooling capacity (sensible)	$P_{rated,c}$	12.4	kW	Total electric power input	P_{elec}	0.430	kW
Cooling capacity (latent)	$P_{rated,c}$	3.6	kW	Sound power level (per speed setting,if applicable)	L_{WA}	76.0	dB
Heating capacity	$P_{rated,h}$	18.0	kW				
Contact details	Mitsubishi heavy industries thermal systems,LTD						

Model(s) : FDUT15KXE6F-E							
Item	Symbol	Value	Unit	Item	Symbol	Value	Unit
Cooling capacity (sensible)	$P_{rated,c}$	1.2	kW	Total electric power input	P_{elec}	0.060	kW
Cooling capacity (latent)	$P_{rated,c}$	0.3	kW	Sound power level (per speed setting,if applicable)	L_{WA}	52.0	dB
Heating capacity	$P_{rated,h}$	1.7	kW				
Contact details	Mitsubishi heavy industries thermal systems,LTD						

Model(s) : FDUT22KXE6F-E							
Item	Symbol	Value	Unit	Item	Symbol	Value	Unit
Cooling capacity (sensible)	$P_{rated,c}$	1.7	kW	Total electric power input	P_{elec}	0.070	kW
Cooling capacity (latent)	$P_{rated,c}$	0.5	kW	Sound power level (per speed setting,if applicable)	L_{WA}	52.0	dB
Heating capacity	$P_{rated,h}$	2.5	kW				
Contact details	Mitsubishi heavy industries thermal systems,LTD						

Model(s) : FDUT28KXE6F-E							
Item	Symbol	Value	Unit	Item	Symbol	Value	Unit
Cooling capacity (sensible)	$P_{rated,c}$	2.0	kW	Total electric power input	P_{elec}	0.070	kW
Cooling capacity (latent)	$P_{rated,c}$	0.8	kW	Sound power level (per speed setting,if applicable)	L_{WA}	52.0	dB
Heating capacity	$P_{rated,h}$	3.2	kW				
Contact details	Mitsubishi heavy industries thermal systems,LTD						

Model(s) : FDUT36KXE6F-E							
Item	Symbol	Value	Unit	Item	Symbol	Value	Unit
Cooling capacity (sensible)	$P_{rated,c}$	2.5	kW	Total electric power input	P_{elec}	0.070	kW
Cooling capacity (latent)	$P_{rated,c}$	1.1	kW	Sound power level (per speed setting,if applicable)	L_{WA}	57.0	dB
Heating capacity	$P_{rated,h}$	4.0	kW				
Contact details	Mitsubishi heavy industries thermal systems,LTD						

Model(s) : FDUT45KXE6F-E							
Item	Symbol	Value	Unit	Item	Symbol	Value	Unit
Cooling capacity (sensible)	$P_{rated,c}$	3.2	kW	Total electric power input	P_{elec}	0.080	kW
Cooling capacity (latent)	$P_{rated,c}$	1.3	kW	Sound power level (per speed setting,if applicable)	L_{WA}	58.0	dB
Heating capacity	$P_{rated,h}$	5.0	kW				
Contact details	Mitsubishi heavy industries thermal systems,LTD						

Model(s) : FDUT56KXE6F-E							
Item	Symbol	Value	Unit	Item	Symbol	Value	Unit
Cooling capacity (sensible)	$P_{rated,c}$	3.9	kW	Total electric power input	P_{elec}	0.080	kW
Cooling capacity (latent)	$P_{rated,c}$	1.7	kW	Sound power level (per speed setting,if applicable)	L_{WA}	59.0	dB
Heating capacity	$P_{rated,h}$	6.0	kW				
Contact details	Mitsubishi heavy industries thermal systems,LTD						

Model(s) : FDUT71KXE6F-E							
Item	Symbol	Value	Unit	Item	Symbol	Value	Unit
Cooling capacity (sensible)	$P_{rated,c}$	4.9	kW	Total electric power input	P_{elec}	0.080	kW
Cooling capacity (latent)	$P_{rated,c}$	2.2	kW	Sound power level (per speed setting,if applicable)	L_{WA}	59.0	dB
Heating capacity	$P_{rated,h}$	8.0	kW				
Contact details	Mitsubishi heavy industries thermal systems,LTD						

Model(s) : FDUH22KXE6F							
Item	Symbol	Value	Unit	Item	Symbol	Value	Unit
Cooling capacity (sensible)	$P_{rated,c}$	1.8	kW	Total electric power input	P_{elec}	0.060	kW
Cooling capacity (latent)	$P_{rated,c}$	0.4	kW	Sound power level (per speed setting,if applicable)	L_{WA}	60.0	dB
Heating capacity	$P_{rated,h}$	2.5	kW				
Contact details	Mitsubishi heavy industries thermal systems,LTD						

Model(s) : FDUH28KXE6F							
Item	Symbol	Value	Unit	Item	Symbol	Value	Unit
Cooling capacity (sensible)	$P_{rated,c}$	2.2	kW	Total electric power input	P_{elec}	0.060	kW
Cooling capacity (latent)	$P_{rated,c}$	0.6	kW	Sound power level (per speed setting,if applicable)	L_{WA}	60.0	dB
Heating capacity	$P_{rated,h}$	3.2	kW				
Contact details	Mitsubishi heavy industries thermal systems,LTD						

Model(s) : FDUH36KXE6F							
Item	Symbol	Value	Unit	Item	Symbol	Value	Unit
Cooling capacity (sensible)	$P_{rated,c}$	2.6	kW	Total electric power input	P_{elec}	0.060	kW
Cooling capacity (latent)	$P_{rated,c}$	1.0	kW	Sound power level (per speed setting,if applicable)	L_{WA}	60.0	dB
Heating capacity	$P_{rated,h}$	4.0	kW				
Contact details	Mitsubishi heavy industries thermal systems,LTD						

Model(s) : FDFW28KXE6F							
Item	Symbol	Value	Unit	Item	Symbol	Value	Unit
Cooling capacity (sensible)	$P_{rated,c}$	2.3	kW	Total electric power input	P_{elec}	0.020	kW
Cooling capacity (latent)	$P_{rated,c}$	0.5	kW	Sound power level (per speed setting,if applicable)	L_{WA}	55.0	dB
Heating capacity	$P_{rated,h}$	3.2	kW				
Contact details	Mitsubishi heavy industries thermal systems,LTD						

Model(s) : FDFW45KXE6F							
Item	Symbol	Value	Unit	Item	Symbol	Value	Unit
Cooling capacity (sensible)	$P_{rated,c}$	3.0	kW	Total electric power input	P_{elec}	0.020	kW
Cooling capacity (latent)	$P_{rated,c}$	1.5	kW	Sound power level (per speed setting,if applicable)	L_{WA}	57.0	dB
Heating capacity	$P_{rated,h}$	5.0	kW				
Contact details	Mitsubishi heavy industries thermal systems,LTD						

Model(s) : FDFW56KXE6F							
Item	Symbol	Value	Unit	Item	Symbol	Value	Unit
Cooling capacity (sensible)	$P_{rated,c}$	3.8	kW	Total electric power input	P_{elec}	0.030	kW
Cooling capacity (latent)	$P_{rated,c}$	1.8	kW	Sound power level (per speed setting,if applicable)	L_{WA}	60.0	dB
Heating capacity	$P_{rated,h}$	6.3	kW				
Contact details	Mitsubishi heavy industries thermal systems,LTD						

Model(s) : FDE36KXZE1							
Item	Symbol	Value	Unit	Item	Symbol	Value	Unit
Cooling capacity (sensible)	$P_{rated,c}$	2.7	kW	Total electric power input	P_{elec}	0.050	kW
Cooling capacity (latent)	$P_{rated,c}$	0.9	kW	Sound power level (per speed setting,if applicable)	L_{WA}	60.0	dB
Heating capacity	$P_{rated,h}$	4.0	kW				
Contact details	Mitsubishi heavy industries thermal systems,LTD						

Model(s) : FDE45KXZE1							
Item	Symbol	Value	Unit	Item	Symbol	Value	Unit
Cooling capacity (sensible)	$P_{rated,c}$	3.3	kW	Total electric power input	P_{elec}	0.050	kW
Cooling capacity (latent)	$P_{rated,c}$	1.2	kW	Sound power level (per speed setting,if applicable)	L_{WA}	60.0	dB
Heating capacity	$P_{rated,h}$	5.0	kW				
Contact details	Mitsubishi heavy industries thermal systems,LTD						

Model(s) : FDE56KXZE1							
Item	Symbol	Value	Unit	Item	Symbol	Value	Unit
Cooling capacity (sensible)	$P_{rated,c}$	3.9	kW	Total electric power input	P_{elec}	0.050	kW
Cooling capacity (latent)	$P_{rated,c}$	1.7	kW	Sound power level (per speed setting,if applicable)	L_{WA}	60.0	dB
Heating capacity	$P_{rated,h}$	6.3	kW				
Contact details	Mitsubishi heavy industries thermal systems,LTD						

Model(s) : FDE71KXZE1							
Item	Symbol	Value	Unit	Item	Symbol	Value	Unit
Cooling capacity (sensible)	$P_{rated,c}$	5.2	kW	Total electric power input	P_{elec}	0.070	kW
Cooling capacity (latent)	$P_{rated,c}$	1.9	kW	Sound power level (per speed setting,if applicable)	L_{WA}	62.0	dB
Heating capacity	$P_{rated,h}$	8.0	kW				
Contact details	Mitsubishi heavy industries thermal systems,LTD						

Model(s) : FDE112KXZE1							
Item	Symbol	Value	Unit	Item	Symbol	Value	Unit
Cooling capacity (sensible)	$P_{rated,c}$	7.9	kW	Total electric power input	P_{elec}	0.100	kW
Cooling capacity (latent)	$P_{rated,c}$	3.3	kW	Sound power level (per speed setting,if applicable)	L_{WA}	63.0	dB
Heating capacity	$P_{rated,h}$	12.5	kW				
Contact details	Mitsubishi heavy industries thermal systems,LTD						

Model(s) : FDE140KXZE1							
Item	Symbol	Value	Unit	Item	Symbol	Value	Unit
Cooling capacity (sensible)	$P_{rated,c}$	9.8	kW	Total electric power input	P_{elec}	0.130	kW
Cooling capacity (latent)	$P_{rated,c}$	4.2	kW	Sound power level (per speed setting,if applicable)	L_{WA}	66.0	dB
Heating capacity	$P_{rated,h}$	16.0	kW				
Contact details	Mitsubishi heavy industries thermal systems,LTD						

Model(s) : FDU650FKXZE1							
Item	Symbol	Value	Unit	Item	Symbol	Value	Unit
Cooling capacity (sensible)	$P_{rated,c}$	3.2	kW	Total electric power input	P_{elec}	0.250	kW
Cooling capacity (latent)	$P_{rated,c}$	5.8	kW	Sound power level (per speed setting,if applicable)	L_{WA}	62.0	dB
Heating capacity	$P_{rated,h}$	6.5	kW				
Contact details	Mitsubishi heavy industries thermal systems,LTD						

Model(s) : FDU1100FKXZE1							
Item	Symbol	Value	Unit	Item	Symbol	Value	Unit
Cooling capacity (sensible)	$P_{rated,c}$	4.1	kW	Total electric power input	P_{elec}	0.360	kW
Cooling capacity (latent)	$P_{rated,c}$	9.9	kW	Sound power level (per speed setting,if applicable)	L_{WA}	66.0	dB
Heating capacity	$P_{rated,h}$	10.5	kW				
Contact details	Mitsubishi heavy industries thermal systems,LTD						

Model(s) : FDU1800FKXZE1							
Item	Symbol	Value	Unit	Item	Symbol	Value	Unit
Cooling capacity (sensible)	$P_{rated,c}$	7.4	kW	Total electric power input	P_{elec}	1.180	kW
Cooling capacity (latent)	$P_{rated,c}$	15.1	kW	Sound power level (per speed setting,if applicable)	L_{WA}	70.0	dB
Heating capacity	$P_{rated,h}$	16.0	kW				
Contact details	Mitsubishi heavy industries thermal systems,LTD						

Model(s) : FDU2400FKXZE1							
Item	Symbol	Value	Unit	Item	Symbol	Value	Unit
Cooling capacity (sensible)	$P_{rated,c}$	9.3	kW	Total electric power input	P_{elec}	1.180	kW
Cooling capacity (latent)	$P_{rated,c}$	18.7	kW	Sound power level (per speed setting,if applicable)	L_{WA}	73.0	dB
Heating capacity	$P_{rated,h}$	21.5	kW				
Contact details	Mitsubishi heavy industries thermal systems,LTD						

Model(s) : SAF-DX250E6							
Item	Symbol	Value	Unit	Item	Symbol	Value	Unit
Cooling capacity (sensible)	$P_{rated,c}$	1.3	kW	Total electric power input	P_{elec}	0.007	kW
Cooling capacity (latent)	$P_{rated,c}$	0.7	kW	Sound power level (per speed setting,if applicable)	L_{WA}	-	dB
Heating capacity	$P_{rated,h}$	1.8	kW				
Contact details	Mitsubishi heavy industries thermal systems,LTD						

Model(s) : SAF-DX350E6							
Item	Symbol	Value	Unit	Item	Symbol	Value	Unit
Cooling capacity (sensible)	$P_{rated,c}$	1.8	kW	Total electric power input	P_{elec}	0.007	kW
Cooling capacity (latent)	$P_{rated,c}$	1.0	kW	Sound power level (per speed setting,if applicable)	L_{WA}	-	dB
Heating capacity	$P_{rated,h}$	2.2	kW				
Contact details	Mitsubishi heavy industries thermal systems,LTD						

Model(s) : SAF-DX500E6							
Item	Symbol	Value	Unit	Item	Symbol	Value	Unit
Cooling capacity (sensible)	$P_{rated,c}$	2.4	kW	Total electric power input	P_{elec}	0.007	kW
Cooling capacity (latent)	$P_{rated,c}$	1.2	kW	Sound power level (per speed setting,if applicable)	L_{WA}	-	dB
Heating capacity	$P_{rated,h}$	2.8	kW				
Contact details	Mitsubishi heavy industries thermal systems,LTD						

Model(s) : SAF-DX800E6							
Item	Symbol	Value	Unit	Item	Symbol	Value	Unit
Cooling capacity (sensible)	$P_{rated,c}$	3.7	kW	Total electric power input	P_{elec}	0.007	kW
Cooling capacity (latent)	$P_{rated,c}$	1.9	kW	Sound power level (per speed setting,if applicable)	L_{WA}	-	dB
Heating capacity	$P_{rated,h}$	4.5	kW				
Contact details	Mitsubishi heavy industries thermal systems,LTD						

Model(s) : SAF-DX1000E6							
Item	Symbol	Value	Unit	Item	Symbol	Value	Unit
Cooling capacity (sensible)	$P_{rated,c}$	4.2	kW	Total electric power input	P_{elec}	0.007	kW
Cooling capacity (latent)	$P_{rated,c}$	2.1	kW	Sound power level (per speed setting,if applicable)	L_{WA}	-	dB
Heating capacity	$P_{rated,h}$	5.6	kW				
Contact details	Mitsubishi heavy industries thermal systems,LTD						

VRF INVERTER MULTI-SYSTEM AIR-CONDITIONERS



MITSUBISHI HEAVY INDUSTRIES THERMAL SYSTEMS, LTD.

16-5 Konan 2-chome, Minato-ku, Tokyo, 108-8215, Japan

<http://www.mhi-mth.co.jp/en/>

Because of our policy of continuous improvement, we reserve the right to make changes in all specifications without notice.

© Copyright MITSUBISHI HEAVY INDUSTRIES THERMAL SYSTEMS, LTD.