



# SERVICE MANUAL

## INVERTER PACKAGED AIR-CONDITIONERS (Split system, air to air heat pump type)

### HYPER INVERTER

#### CEILING CASSETTE - 4 WAY TYPE

Single type	Twin type
FDT71VNXVH	FDT140VNXPVH
100VNXVH	140VSXPVH
100VSXVH	
125VNXVH	
125VSXVH	
140VNXVH	
140VSXVH	

#### V Multi system

(OUTDOOR UNIT)	(INDOOR UNIT)
FDC125VNX	FDT50VH
125VSX	71VH
140VNX	
140VSX	

### MICRO INVERTER

#### CEILING CASSETTE - 4 WAY TYPE

Single type	Twin type	Triple type
FDT100VNAVH	FDT140VNAPVH	FDT200VSATVH
100VSAVH	140VSAPVH	
125VNAVH	200VSAPVH	
125VSAVH	250VSAPVH	
140VNAVH		
140VSAVH		

#### V Multi system

(OUTDOOR UNIT)	(INDOOR UNIT)
FDC125VNA	FDT50VH
125VSA	60VH
140VNA	71VH
140VSA	100VH
200VSA	125VH
250VSA	

### STANDARD INVERTER

#### CEILING CASSETTE - 4 WAY TYPE

Single type
FDT71VNPVH
90VNP1VH
100VNP1VH

## TABLE OF CONTENTS

1. HYPER INVERTER PACKAGED AIR-CONDITIONERS .....	2
2. MICRO INVERTER PACKAGED AIR-CONDITIONERS .....	172
3. STANDARD INVERTER PACKAGED AIR-CONDITIONERS .....	200
4. V MULTI SYSTEM .....	223

# 1. HYPER INVERTER PACKAGED AIR-CONDITIONERS

## CONTENTS

<b>1.1 OUTLINE OF OPERATION CONTROL BY MICROCOMPUTER</b>	<b>4</b>
<b>1.1.1 Remote control (Option parts)</b>	<b>4</b>
<b>1.1.2 Operation control function by the wired remote control</b>	<b>7</b>
<b>1.1.3 Operation control function by the indoor control</b>	<b>10</b>
(1) Auto operation	10
(2) Operations of functional items during cooling/heating	11
(3) Dehumidifying (DRY) operation	11
(4) Timer operation	12
(5) Hot start (Cold draft prevention at heating)	13
(6) Hot keep	13
(7) Auto swing control	14
(8) Thermostat operation	15
(9) Filter sign	16
(10) Compressor inching prevention control	16
(11) Drain pump control	17
(12) Drain pump motor (DM) control	17
(13) Operation check/drain pump test run operation mode	17
(14) Cooling, dehumidifying frost protection	18
(15) Heating overload protection	18
(16) Anomalous fan motor	18
(17) Plural unit control - Control of 16 units group by one remote control	19
(18) High ceiling control	19
(19) Abnormal temperature sensor (return air/indoor heat exchanger) broken wire/short-circuit detection	20
(20) External input/output control (CnT or CnTA)	20
(21) Operation permission/prohibition	22
(22) Temporary stop input	24
(23) Selection of cooling/heating external input function	24
(24) Fan control at heating startup	25
(25) Room temperature detection temperature compensation during heating	25
(26) Return air temperature compensation	25
(27) High power operation (RC-EX3A only)	25
(28) Energy-saving operation (RC-EX3A only)	25
(29) Warm-up control (RC-EX3A only)	25
(30) Home leave mode (RC-EX3A only)	25
(31) Auto temperature setting (RC-EX3A only)	25
(32) Fan circulator operation (RC-EX3A only)	26
(33) The operation judgment is executed every 5 minutes (RC-EX3A only)	26

(34) Auto fan speed control (RC-EX3A only) .....	26
(35) Indoor unit overload alarm (RC-EX3A only) .....	26
(36) Peak-cut timer (RC-EX3A only) .....	26
(37) Motion sensor control (RC-EX3A and RCN-E2 only) .....	27
<b>1.1.4 Operation control function by the outdoor control .....</b>	<b>29</b>
<b>Models FDC71 – 140 .....</b>	<b>29</b>
(1) Determination of compressor speed (Frequency) .....	29
(2) Compressor start control .....	29
(3) Compressor soft start control .....	30
(4) Outdoor fan control .....	31
(5) Defrost operation .....	33
(6) Protective control/anomalous stop control by compressor's number of revolutions .....	34
(7) Silent mode .....	38
(8) Test run .....	38
(9) Pump-down control .....	38
(10) Base heater ON/OFF output control (Option) .....	39
<b>1.2 MAINTENANCE DATA .....</b>	<b>40</b>
<b>1.2.1 Diagnosing of microcomputer circuit .....</b>	<b>40</b>
(1) Selfdiagnosis function .....	40
(2) Troubleshooting procedure .....	45
(3) Troubleshooting at the indoor unit .....	45
(4) Troubleshooting at the outdoor unit .....	48
(5) Check of anomalous operation data with the remote control .....	73
(6) Power transistor module (Including the driver PCB) inspection procedure .....	76
(7) Inverter checker for diagnosis of inverter output .....	78
(8) Outdoor unit control failure diagnosis circuit diagram .....	80
<b>1.2.2 Troubleshooting flow .....</b>	<b>90</b>
(1) List of troubles .....	90
(2) Troubleshooting .....	93
<b>1.3 ELECTRICAL WIRING .....</b>	<b>166</b>
<b>1.4 PIPING SYSTEM.....</b>	<b>170</b>

# 1.1 OUTLINE OF OPERATION CONTROL BY MICROCOMPUTER

## 1.1.1 Remote control (Option parts)

### (1) Wired remote control

Model RC-EX3A

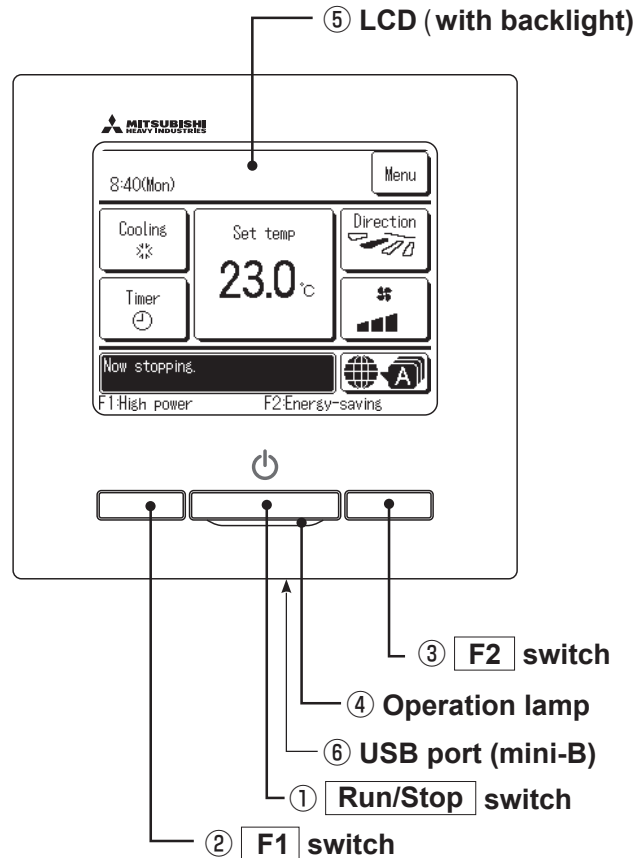

Touch panel system, which is operated by tapping the LCD screen with a finger, is employed for any operations other than the ①Run/Stop, ②F1 and ③F2 switches.

#### ① Run/Stop switch

One push on the button starts operation and another push stops operation.

If the backlight is ON setting, when the screen is tapped while the backlight is turned off, the backlight only is turned on. (Operations with switches ①, ② and ③ are excluded.)

#### ② F1 switch ③ F2 switch

This switch starts operation that is set in F1/F2 function change.

#### ⑥ USB port

USB connector (mini-B) allows connecting to a personal computer.

#### ④ Operation lamp

This lamp lights in green (yellow-green) during operation. It changes to red (orange) if any error occurs.  
Operation lamp luminance can be changed.

For operating methods, refer to the instruction manual attached to the software for personal computer (remote control utility software).

#### ⑤ LCD (with backlight)

A tap on the LCD lights the backlight.  
The backlight turns off automatically if there is no operation for certain period of time.  
Lighting period of the backlight lighting can be changed.

Note(1) When connecting to a personal computer, do not connect simultaneously with other USB devices.  
Please be sure to connect to the computer directly, without going through a hub, etc.

**Model RC-E5**

The figure below shows the remote control with the cover opened. Note that all the items that may be displayed in the liquid crystal display area are shown in the figure for the sake of explanation. Characters displayed with dots in the liquid crystal display area are abbreviated.

The figure below shows the remote control with the cover opened.

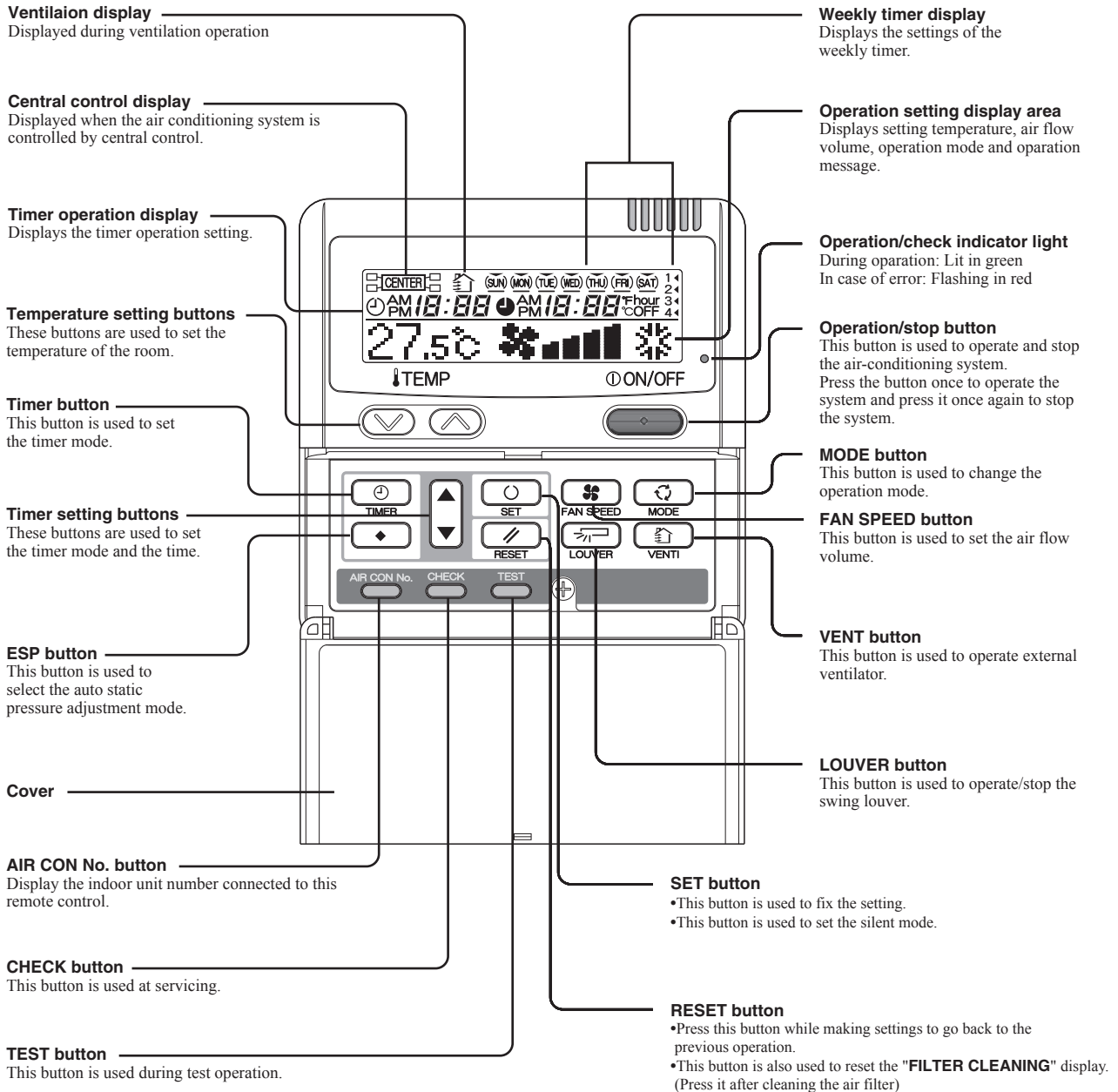

\* All displays are described in the liquid crystal display for explanation.

**(2) Wireless remote control**  
**RCN-E2**

Indication section

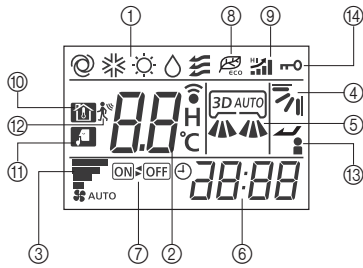

①	OPERATION MODE display	Indicates selected operation mode.
	SET TEMP display	Indicates set temperature.
②	SLEEP TIMER time display	Indicates the amount of time remaining on the sleep timer.
	Indoor function setting number display	Indicates the setting number of the indoor function setting.
③	FAN SPEED display	Indicates the selected air flow volume.
④	UP/DOWN AIR FLOW display	Indicates the up/down louver position.
⑤	LEFT/RIGHT AIR FLOW display	Indicates the left/right louver position.
⑥	Clock display	Indicates the current time. If the timer is set, the ON TIMER and OFF TIMER setting times are indicated.
⑦	ON/OFF TIMER display	Displayed when the timer is set.
⑧	ECO mode display	Displayed when the energy-saving operation is active.
⑨	HI POWER display	Displayed when the high power operation is active.
⑩	NIGHT SETBACK display	Displayed when the home leave mode is active.
⑪	SILENT display	Displayed when the silent mode control is active.
⑫	Motion sensor display	Displayed when the infrared sensor control(motion sensor control) is enabled.
⑬	Anti draft setting display	Displayed when anti draft setting is enabled.
⑭	Child lock display	Displayed when child lock is enabled.

Operation section

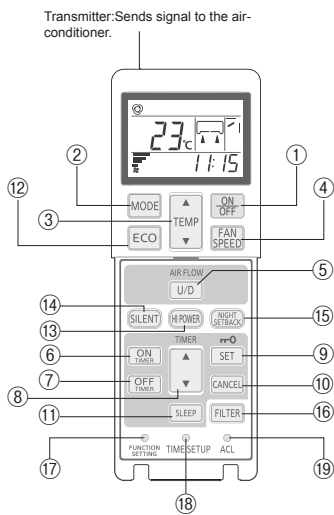

①	ON/OFF button	When this is pressed once, the air-conditioner starts to operate and when this is pressed once again, it stops operating.
②	MODE button	Every time this button is pressed, displays switch as below 
③	TEMP button	Change the set temperature by pressing ▲ or ▼ button.
④	FAN SPEED button	The fan speed is switched in the following order: 1-speed → 2-speed → 3-speed → 4-speed → AUTO → 1-speed.
⑤	U/D button	Used to determine the up/down louver position.
⑥	ON TIMER button	Used to set the ON TIMER.
⑦	OFF TIMER button	Used to set the OFF TIMER.
⑧	SELECT button	Used to switch the time when setting the timer or adjusting the time. Used to switch the settings of the indoor function.
⑨	SET button	Used to determine the setting when setting the timer or adjusting the time. Used to determine the settings of the indoor function. When press and hold SET button ,Child Lock is enabled.
⑩	CANCEL button	Used to cancel the timer setting.
⑪	SLEEP button	Used to set the sleep timer.
⑫	ECO button	Pressing this button starts the energy-saving operation. Pressing this button again cancels it.
⑬	HI POWER button	Pressing this button starts the high power operation. Pressing this button again cancels it.
⑭	SILENT button	Pressing this button starts the silent mode control. Pressing this button again cancels it.
⑮	NIGHT SETBACK button	Pressing this button starts the home leave mode. Pressing this button again cancels it.
⑯	FILTER button	Pressing this button resets FILTER SIGN.
⑰	FUNCTION SETTING switch	Used to set the indoor function.
⑱	TIME SETUP switch	Used to set the current time.
⑲	ACL switch	Used to reset the microcomputer.

## 1.1.2 Operation control function by the wired remote control

### ● Model RC-EX3A

#### (1) Switching sequence of the operation mode switches of remote control

- Tap the change operation mode button on the TOP screen.
- When the change operation mode screen is displayed, tap the button of desired mode.
- When the operation mode is selected, the display returns to the TOP screen.

Icons displayed have the following meanings.

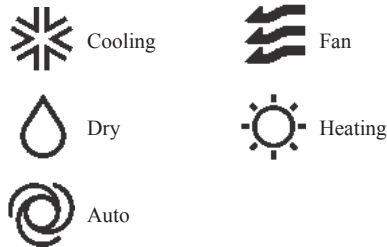

Notes(1) Operation modes which cannot be selected depending on combinations of indoor unit and outdoor unit are not displayed.

- When the Auto is selected, the cooling and heating switching operation is performed automatically according to indoor and outdoor temperatures.

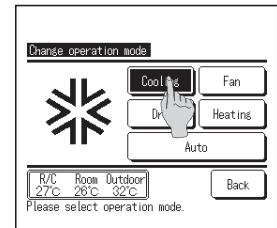
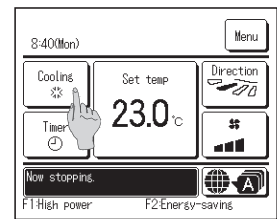

#### (2) CPU reset

Reset CPU from the remote control as follows.

TOP screen → Menu → Service setting → Service & Maintenance → Service password

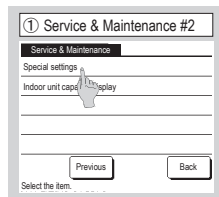

The selected screen is displayed.

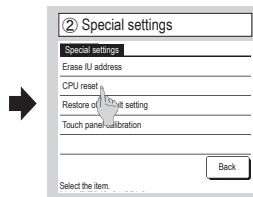

The selected screen is displayed.

#### CPU reset

Microcomputers of indoor unit and outdoor unit connected are reset (State of restoration after power failure).

#### (3) Power failure compensation function (Electric power source failure)

Enable the Auto-restart function from the remote control as follows.

TOP screen → Menu → Service setting → R/C function settings → Service password

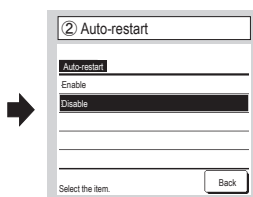
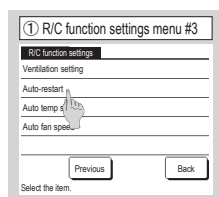

If the unit stops during operation,

#### Enable

It returns to the state before the power failure as soon as the power source is restored (After the end of the primary control at the power on).

#### Disable

It stops after the restoration of power source.

● Since the status of remote control is retained in memory always, it restarts operations according to the contents of memory as soon as the power source is restored. Although the timer mode is cancelled, the weekly timer, peak cut timer and silent mode timer operate according to the following contents:

- When the clock setting is valid : These timer settings are also valid.
- When the clock setting is invalid : These timer settings become “Invalid” since the clock setting is invalid. These timer settings have to be changed to “Valid” after the timer setting.



- Content memorized with the power failure compensation are as follows.

Note(1) Items (f) and (g) are memorized regardless whether the power failure compensation is effective or not while the setting of silent mode is cancelled regardless whether the power failure compensation is effective or not.

- (a) At power failure – Operating/stopped
  - If it had been operating under the off timer mode, sleep timer mode, the state of stop is memorized.
- (b) Operation mode
- (c) Air flow volume mode
- (d) Room temperature setting
- (e) Louver auto swing/stop
  - However, the stop position (4-position) is cancelled so that it returns to Position (1).
- (f) “Remote control function items” which have been set with the administrator or installation function settings (“Indoor function items” are saved in the memory of indoor unit.)
- (g) Weekly timer, peak-cut timer or silent mode timer settings
- (h) Remote control function setting

**(4) Alert displays**

If the following (a) to (c) appear, check and repair as follows.

**(a) Communication check between indoor unit and remote control**



- This appears if communications cannot be established between the remote control and the indoor unit.  
Check whether the system is correctly connected (indoor unit, outdoor unit, remote control) and whether the power source for the outdoor unit is connected.

**(b) Clock setting check**

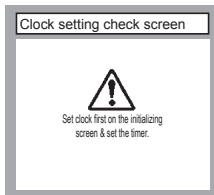

- This appears when the timer settings are done without clock setting.  
Set the clock setting before the timer settings.

**(c) Misconnection**

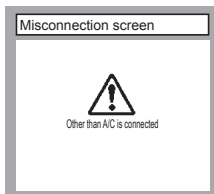

- This appears when something other than the air-conditioner has been connected to the remote control.  
Check the location to which the remote control is connected.

● Model RC-E5

(1) Switching sequence of the operation mode switches of remote control



(2) CPU reset

This functions when “CHECK” and “ESP” buttons on the remote control are pressed simultaneously. Operation is same as that of the power source reset.

(3) Power failure compensation function (Electric power source failure)

- This becomes effective if “Power failure compensation effective” is selected with the setting of remote control function.
- Since it memorizes always the condition of remote control, it starts operation according to the contents of memory no sooner than normal state is recovered after the power failure. Although the auto swing stop position and the timer mode are cancelled, the weekly timer setting is restored with the holiday setting for all weekdays. After recovering from the power failure, it readjusts the clock and resets the holiday setting for each weekday so that the setting of weekly timer becomes effective.
- Content memorized with the power failure compensation are as follows.

Note (1) Items (f), (g) and (h) are memorized regardless whether the power failure compensation is effective or not while the setting of silent mode is cancelled regardless whether the power failure compensation is effective or not.

- (a) At power failure – Operating/stopped  
If it had been operating under the off timer mode, sleep timer mode, the state of stop is memorized. (Although the timer mode is cancelled at the recovery from power failure, the setting of weekly timer is changed to the holiday setting for all weekdays.)
- (b) Operation mode
- (c) Air flow volume mode
- (d) Room temperature setting
- (e) Louver auto swing/stop  
However, the stop position (4-position) is cancelled so that it returns to Position (1).
- (f) “Remote control function items” which have been set with the remote control function setting (“Indoor function items” are saved in the memory of indoor unit.)
- (g) Upper limit value and lower limit value which have been set with the temperature setting control
- (h) Sleep timer and weekly timer settings (Other timer settings are not memorized.)

[Parts layout on remote control PCB]

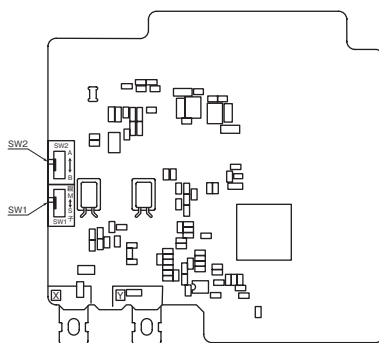

**Master/ slave setting when more than one remote controls are used**

A maximum of two remote controls can be connected to one indoor unit (or one group of indoor units.)

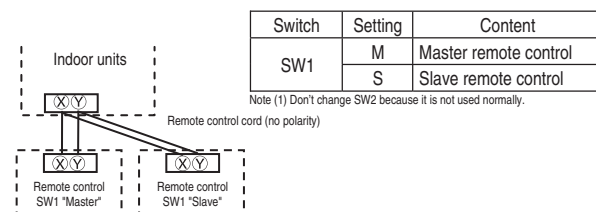

**Caution**

When using multiple remote controls, the following displays or settings cannot be done with the slave remote control. It is available only with the master remote control.

- ① Louver position setting (set upper or lower limit of swinging range)
- ② Setting indoor unit functions
- ③ Setting temperature range
- ④ Operation data display
- ⑤ Error data display
- ⑥ Silent mode setting
- ⑦ Test operation of drain pump
- ⑧ Remote control sensor setting

### 1.1.3 Operation control function by the indoor control

#### (1) Auto operation

- (a) If "Auto" mode is selected by the remote control, the heating and the cooling are automatically switched according to the difference between outdoor air temperature and setting temperature and the difference between setting temperature and return air temperature. (When the switching of cooling mode ↔ heating mode takes place within 3 minutes, the compressor does not operate for 3 minutes by the control of 3-minute timer.) This will facilitate the cooling/heating switching operation in intermediate seasons and the adaptation to unmanned operation at stores, etc (ATM corner of bank).

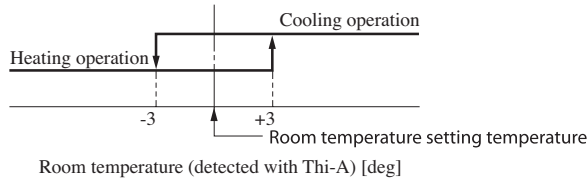

Notes (1) Temperature range of switching cooling/heating mode can be changed by RC-EX3 from ±1.0 – ±4.0.

- (2) Room temperature control during auto cooling/auto heating is performed according to the room temperature setting temperature. (DIFF: ±1 deg)
- (3) If the indoor heat exchanger temperature rises to 59°C or higher during heating operation, it is switched automatically to cooling operation. In addition, for 1 hour after this switching, the heating operation is not performed, regardless of the temperature shown at right.

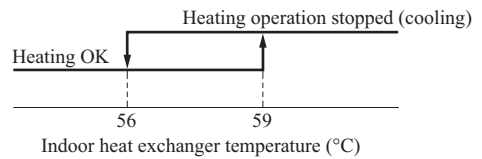

- (b) The following automatic controls are performed other than (a) above.
- (i) Cooling or heating operation mode is judged according to the conditions of the "Judgment based on Setting temperature + Cooling select temperature and Indoor return air temperature" and the "Judgment based on Outdoor temperature".
    - 1) In "Setting temperature - Cooling select temperature < Indoor return air temperature" and "Outdoor temperature/Cooling < Outdoor return air temperature" ⇒ Operation mode: Cooling
    - 2) "Setting temperature + Heating select temperature > Indoor return air temperature" and "Outdoor temperature/Heating > Outdoor air temperature" ⇒ Operation mode: Heating
    - 3) The outdoor air temperature of the above judgment conditions is sampled at every 10 minutes.
    - 4) In the range where the above cooling and heating zones are overlapped ⇒ Forced thermostat OFF

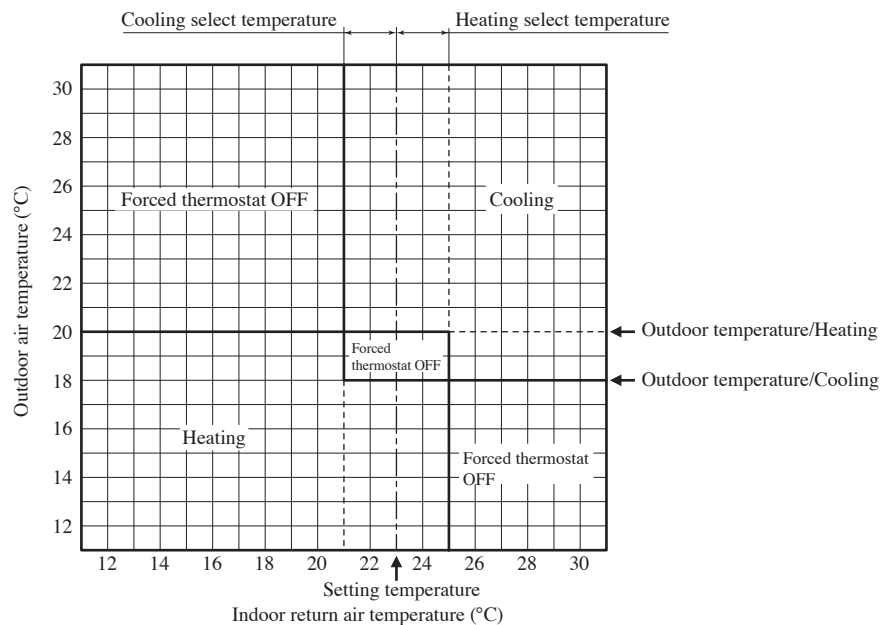

- (ii) Regardless of the setting temperature, the cooling or heating operation mode is judged according to the "Judgment based on Room temperature/Cooling or Heating and Outdoor temperature/Cooling or Heating".
  - 1) In case of "Room temperature/Cooling < Indoor return air temperature" and "Outdoor temperature/Cooling < Outdoor air temperature" ⇒ Operation mode: Cooling
  - 2) In case of "Room temperature/Heating > Indoor return air temperature" and "Outdoor temperature /Heating > Outdoor air temperature" ⇒ Operation mode: Heating
  - 3) The outdoor air temperature of the above judgment conditions is sampled at every 10 minutes.
  - 4) In the range where the above cooling and heating zones are overlapped ⇒ Forced thermostat OFF

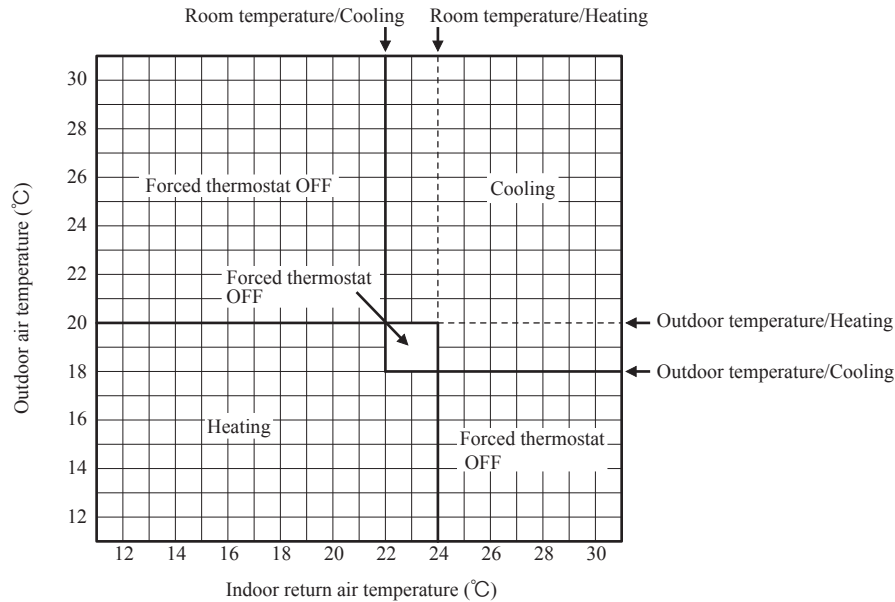

(2) Operations of functional items during cooling/heating

Operation	Cooling		Fan	Heating			Dehumidifying
	Thermostat ON	Thermostat OFF		Thermostat ON	Thermostat OFF	Hot start (Defrost)	
Compressor	○	×	×	○	×	○	○/×
4-way valve	×	×	×	○	○	○(×)	×
Outdoor unit fan	○	×	×	○	×	○(×)	○/×
Indoor unit fan	○	○	○	○/×	○/×	○/×	○/×
Drain pump <sup>(3)</sup>	○	× <sup>(2)</sup>	× <sup>(2)</sup>	○/× <sup>(2)</sup>			Thermostat ON: ○ Thermostat OFF: × <sup>(2)</sup>

Notes (1) ○: Operation ×: Stop ○/×: Turned ON/OFF by the control other than the room temperature control.  
 (2) ON during the drain motor delay control.  
 (3) Drain pump ON setting may be selected with the indoor unit function setting of the wired remote control.

(3) Dehumidifying (DRY) operation

Indoor ambient temperatures and humidity are controlled simultaneously with the relative humidity sensor (HS) and the suction temperature sensor [Thi-A (or the remote control temperature sensor when it is activated)], which are installed at the suction inlet.

- (a) When the operation has been started with cooling, if there is a difference of 2°C or less between the suction and setting temperatures, the tap of indoor fan is lowered by one tap. This tap is retained for 3 minutes after changing the tap.
- (b) After the above condition, when a difference between suction and setting temperature is lower than 3°C, and the relative humidity is high, the tap of indoor unit fan is lowered by one tap.  
 When the difference between suction and setting temperature is larger than 3°C, the fan of indoor unit fan is raised by one tap. This tap is retained for 3 minutes after changing the tap.
- (c) When relative humidity becomes lower, the indoor unit fan tap is retained.
- (d) In case of the thermostat OFF, the indoor unit fan tap at the thermostat ON is retained.

**(4) Timer operation**

**(a) RC-EX3A**

- (i) **Sleep timer**  
Set the time from the start to stop of operation. The time can be selected in the range from 30 to 240 minutes (in the unit of 10-minute).  
Note (1) Enable the "Sleep timer" setting from the remote control. If the setting is enabled, the timer operates at every time.
- (ii) **Set OFF timer by hour**  
Set the time to stop the unit after operation, in the range from 1 to 12 hours (in the unit of hour).
- (iii) **Set ON timer by hour**  
Set the time to start the unit after the stop of operation, in the range from 1 to 12 hours (in the unit of hour). It is allowed also to set simultaneously the indoor temperature, operation mode, air flow rate and warm-up enabled/disabled.
- (iv) **Set ON timer by clock**  
Set the time to start operation. The time can be set in the unit of 5-minute. This setting can be activated only once or at every time. It is allowed also to set simultaneously the indoor temperature, operation mode, air flow rate and warm-up enabled/disabled.  
Note (1) It is necessary to set the clock to use this timer.
- (v) **Set OFF timer by clock**  
Set the time to stop operation. The time can be set in the unit of 5-minute. This setting can be activated only once or at every time.  
Note (1) It is necessary to set the clock to use this timer.
- (vi) **Weekly timer**  
Set the ON or OFF timer for a week. Up to 8 patterns can be set for a day. The day-off setting is provided for holidays and non-business days.  
Note (1) It is necessary to set the clock to use the weekly timer.

**(vii) Combination of patterns which can be set for the timer operations**

	Sleep time	Set OFF timer by hour	Set ON timer by hour	Set OFF timer by clock	Set ON timer by clock	Weekly timer
Sleep time		×	×	○	○	○
Set OFF timer by hour	×		×	×	×	×
Set ON timer by hour	×	×		×	×	×
Set OFF timer by clock	○	×	×		○	×
Set ON timer by clock	○	×	×	○		×
Weekly timer	○	×	×	×	×	

Note (1) ○: Allowed ×: Not

**(b) RC-E5**

- (i) **Sleep timer**  
Set the duration of time from the present to the time to turn off the air-conditioner.  
It can be selected from 10 steps in the range from "OFF 1 hour later" to "OFF 10 hours later". After the sleep timer setting, the remaining time is displayed with progress of time in the unit of hour.
- (ii) **OFF timer**  
Time to turn OFF the air-conditioner can be set in the unit of 10 minutes.
- (iii) **ON timer**  
Time to turn ON the air-conditioner can be set. Indoor temperature can be set simultaneously.
- (iv) **Weekly timer**  
Timer operation (ON timer, OFF timer) can be set up to 4 times a day for each weekday.
- (v) **Timer operations which can be set in combination**

Item	Item	Timer	OFF timer	ON timer	Weekly timer
Timer			×	○	×
OFF timer	×			○	×
ON timer	○		○		×
Weekly timer	×	×	×	×	

Notes (1) ○: Allowed ×: Not

(2) Since the ON timer, sleep timer and OFF timer are set in parallel, when the times to turn ON and OFF the air-conditioner are duplicated, the setting of the OFF timer has priority.

**(5) Hot start (Cold draft prevention at heating)****(a) Operating conditions**

When either one of following conditions is satisfied, the hot start control is performed.

- (i) From stop to heating operation
- (ii) From cooling to heating operation
- (iii) Form heating thermostat OFF to ON
- (iv) After completing the defrost operation (only on units with thermostat ON)

**(b) Contents of operation****(i) Indoor fan motor control at hot start**

- 1) Within 7 minutes after starting heating operation, the fan mode is determined depending on the condition of thermostat (fan control with heating thermostat OFF).

**a) Thermostat OFF**

- i) Operates according to the fan control setting at heating thermostat OFF.
- ii) Even if it changes from thermostat OFF to ON, the fan continues to operate with the fan control at thermostat OFF till the heat exchanger thermistor (Thi-R1 or R2, whichever higher) detects 35°C or higher.
- iii) When the heat exchanger thermistor (Thi-R1 or R2, whichever higher) detects 35°C or higher, the fan operates with the set air flow volume.

**b) Thermostat ON**

- i) When the heat exchanger thermistor (Thi-R1 or R2, whichever higher) detects 25°C or lower, the fan is turned OFF and does not operate.
- ii) When the heat exchanger thermistor (Thi-R1 or R2, whichever higher) detects 25°C or higher, the fan operates with the fan control at heating thermostat OFF.
- iii) When the heat exchanger thermistor (Thi-R1 or R2, whichever higher) detects 35°C or higher, the fan operates with the set air flow volume.

- c) If the fan control at heating thermostat OFF is set at the “Set air flow volume” (from the remote control), the fan operates with the set air flow volume regardless of the thermostat ON/OFF.

- 2) Once the fan motor is changed from OFF to ON during the thermostat ON, the indoor fan motor is not turned OFF even if the heat exchanger thermistor detects lower than 25°C.

Note (1) When the defrost control signal is received, it complies with the fan control during defrost operation.

- 3) Once the hot start is completed, it will not restart even if the temperature on the heat exchanger thermistor drops.

(ii) During the hot start, the louver is kept at the horizontal position.

(iii) When the fan motor is turned OFF for 7 minutes continuously after defrost operation, the fan motor is turned ON regardless of the temperatures detected with the indoor heat exchanger thermistors (Thi-R1, R2).

**(c) Ending condition**

(i) If one of following conditions is satisfied during the hot start control, this control is terminated, and the fan is operated with the set air flow volume.

- 1) Heat exchanger thermistor (Thi-R1 or R2, whichever higher) detects 35°C or higher.
- 2) It has elapsed 7 minutes after starting the hot start control.

**(6) Hot keep**

Hot keep control is performed at the start of the defrost operation.

**(a) Control**

- (i) When the indoor heat exchanger temperature (detected with Thi-R1 or R2) drops to less than 35°C, the speed of indoor fan follows fan setting at the time of thermostat OFF.
- (ii) During the hot keep, the louver is kept at the horizontal position.

**(7) Auto swing control**

**Note** Even if [Auto Swing] is selected, the louver position with anti draft function is fixed to position 1.

**(a) RC-EX3A**

(i) Louver control

- 1) To operate the swing louver when the air-conditioner is operating, press the “Direction” button on the TOP screen of remote control. The wind direction select screen will be displayed.
- 2) To swing the louver, touch the “Auto swing” button. The lover will move up and down. To fix the swing louver at a position, touch one of [1] - [4] buttons. The swing lover will stop at the selected position.
- 3) Louver operation at the power on with a unit having the louver 4-position control function  
The louver swings one time automatically (without operating the remote control) at the power on.  
This allows the microcomputer recognizing and inputting the louver motor (LM) position.

(ii) Automatic louver level setting during heating



At the hot start and the heating thermostat OFF, regardless whether the auto swing switch is operated or not (auto swing or louver stop), the louver takes the level position (in order to prevent blowing of cool wind). The louver position display LCD continues to show the display which has been shown before entering this control.

(iii) Louver free stop control

If you touch the “Menu” → “Next” → “R/C settings” buttons one after another on the TOP screen of remote control, the “Flap control” screen is displayed. If the free stop is selected on this screen, the louver motor stops upon receipt of the stop signal from the remote control. If the auto swing signal is received from the remote control, the auto swing will start from the position before the stop.

**(b) RC-E5**

(i) Louver control

- 1) Press the “LOUVER” button to operate the swing louver when the air-conditioner is operating.  
“SWING ” is displayed for 3 seconds and then the swing louver moves up and down continuously.
- 2) To fix the swing louver at a position, press one time the “LOUVER” button while the swing louver is moving so that four stop positions are displayed one after another per second.  
When a desired stop position is displayed, press the “LOUVER” button again. The display stops, changes to show the “STOP 1 ” for 5 seconds and then the swing louver stops.
- 3) Louver operation at the power on with a unit having the louver 4-position control function  
The louver swings one time automatically (without operating the remote control) at the power on.  
This allows inputting the louver motor (LM) position, which is necessary for the microcomputer to recognize the louver position.



Note (1) If you press the “LOUVER” button, the swing motion is displayed on the louver position LCD for 10 seconds. The display changes to the “SWING ” display 3 seconds later.

(ii) Automatic louver level setting during heating

At the hot start with the heating thermostat OFF, regardless whether the auto swing switch is operated or not (auto swing or louver stop), the louver takes the level position (In order to prevent the cold start). The louver position display LCD continues to show the display which has been shown before entering this control.

(iii) Louver-free stop control

When the louver-free stop has been selected with the indoor function of wired remote control “ POSITION”, the louver motor stops when it receives the stop signal from the remote control. If the auto swing signal is received from the remote control, the auto swing will start from the position where it was before the stop.

Note (1) When the indoor function of wired remote control “ POSITION” has been switched, switch also the remote control function “ POSITION” in the same way.

**(8) Thermostat operation****(a) Cooling**

- (i) Thermostat is operated with the room temperature control.
- (ii) Thermostat is turned ON or OFF relative to the set room temperature as shown below.

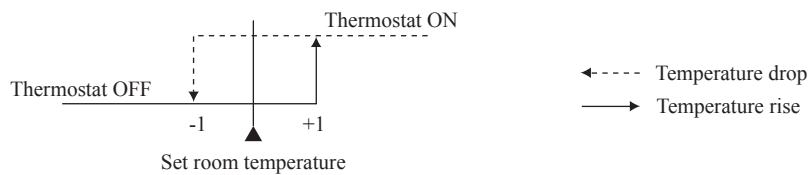

- (iii) Thermostat is turned ON when the room temperature is in the range of  $-1 < \text{Set temperature} < +1$  at the start of cooling operation (including from heating to cooling).

**(b) Heating**

- (i) Thermostat is operated with the room temperature control.
- (ii) Thermostat is turned ON or OFF relative to the set room temperature as shown below.

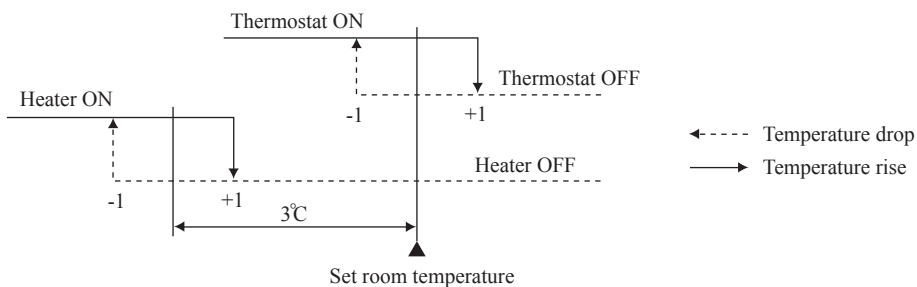

- (iii) Thermostat is turned ON when the room temperature is in the range of  $-1 < \text{Set point} < +1$  at the start of heating operation (including from cooling to heating).

**(c) Fan control during heating thermostat OFF**

- (i) Following fan controls during the heating thermostat OFF can be selected with the indoor function setting of the wired remote control.
  - ① Low fan speed (Factory default), ② Set fan speed, ③ Intermittence, ④ Fan OFF
- (ii) When the “Low fan speed (Factory default)” is selected, the following taps are used for the indoor fans.
  - For DC motor : ULo tap
- (iii) When the “Set fan speed” is selected, it is operated with the set fan speed also in the thermostat OFF condition.
- (iv) If the “Intermittence” is selected, following controls are performed:
  - 1) If the thermostat is turned OFF during the heating operation, the indoor unit moves to the hot control and turns OFF the indoor fan if the heat exchanger thermistors (both Thi-R1 and R2) detect 25°C or lower.
  - 2) Indoor fan OFF is fixed for 5 minutes. After the 5 minutes, the indoor fan is operated at ULo for 2 minutes. In the meantime the louver is controlled at level.
  - 3) After operating at ULo for 2 minutes, the indoor fan moves to the state of 1) above.
  - 4) If the thermostat is turned ON, it moves to the hot start control.
  - 5) When the heating thermostat is turned OFF, the remote control displays the temperature detected at the fan stop and revises the temperature later when the indoor fan changes from ULo to stop. The remote control uses the operation data display function to display temperatures and updates values of temperature even when the indoor fan is turned OFF.
  - 6) When the defrosting starts while the heating thermostat is turned OFF or the thermostat is turned OFF during defrosting, the indoor fan is turned OFF. (Hot keep or hot start control takes priority.) However, the suction temperature is updated at every 7-minute.
  - 7) When the heating thermostat is turned ON or the operation is changed to another mode (including stop), this control is stopped immediately, and the operating condition is restored.
- (v) When the “Fan OFF” is selected, the fan on the indoor unit of which the thermostat has been turned OFF, is turned OFF. The same occurs also when the remote control sensor is effective.



**(d) Fan control during cooling thermostat OFF**

- (i) Following fan controls during the cooling thermostat OFF can be selected with the indoor function setting of the wired remote control.
  - ① Low fan speed, ② Set fan speed (Factory default), ③ Intermittence, ④ Fan OFF
- (ii) When the “Low fan speed” is selected, the following taps are used for the indoor fans.
  - For DC motor : ULo tap
- (iii) When the “Set fan speed” is selected, it is operated with the set fan speed also in the thermostat OFF condition.
- (iv) If the “Intermittence” is selected, following controls are performed:
  - 1) If the thermostat is turned OFF during the cooling operation, the indoor fan motor stops.
  - 2) Indoor fan OFF is fixed for 5 minutes. After the 5 minutes, the indoor fan is operated at ULo for 2 minutes. In the meantime the louver is controlled at level.
  - 3) After operating at ULo for 2 minutes, the indoor fan moves to the state of 1) above.
  - 4) If the thermostat is turned ON, the fan starts operation at set fan speed.
  - 5) When the cooling thermostat is turned OFF, the remote control displays the temperature detected at the fan stop and revises the temperature later when the indoor fan changes from ULo to stop.  
By using operation data display function at wireless remote control, the temperature as displayed and the value is updated including the fan stops.
  - 6) When the cooling thermostat is turned ON or the operation is changed to another mode (including stop), this control is stopped immediately, and the operating condition is restored.
- (v) When the “Fan OFF” is selected, the fan on the indoor unit of which the thermostat has been turned OFF, is turned OFF. The same occurs also when the remote control sensor is effective.

**(9) Filter sign**

As the operation time (Total ON time of ON/OFF switch) accumulates to 180 hours (1), “FILTER CLEANING” is displayed on the remote control. (This is displayed when the unit is in trouble and under the centralized control, regardless of ON/OFF)

Notes (1) Time setting for the filter sign can be made as shown below using the indoor function of wired remote control “Filter sign”. (It is set at setting 1 at the shipping from factory.)

Filter sign setting	Function
Setting 1	Setting time: 180 hrs (Factory default)
Setting 2	Setting time: 600 hrs
Setting 3	Setting time: 1,000 hrs
Setting 4	Setting time: 1,000 hrs (Unit stop) <sup>(2)</sup>

(2) After the setting time has elapsed, the “FILTER CLEANING” is displayed and, after operating for 24 hours further (counted also during the stop), the unit stops.

**(10) Compressor inching prevention control**

**(a) 3-minute timer**

When the compressor has been stopped by the thermostat, remote control operation switch or anomalous condition, its restart will be inhibited for 3 minutes. However, the 3-minute timer is invalidated at the power on the electric power source for the unit.

**(b) 3-minute forced operation timer**

- (i) Compressor will not stop for 3 minutes after the compressor ON. However, it stops immediately when the unit is stopped by means of the ON/OFF switch or when the thermister turned OFF by the change of operation mode.
- (ii) If the thermostat is turned OFF during the forced operation control of heating compressor, the louver position (with the auto swing) is returned to the level position.

Note (1) The compressor stops when it has entered the protective control.

**(11) Drain pump control**

- (a) This control is operated when the inverter frequency is other than 0 Hz during the cooling operation and automatic cooling and dehumidifying operations.
- (b) Drain pump ON condition continues for 5 minutes even when it enters the OFF range according to (i) above after turning the drain pump ON, and then stops. The 5-minute delay continues also in the event of anomalous stop.
- (c) The drain pump is operated with the 5-minute delay operation when the compressor is changed from ON to OFF.
- (d) Even in conditions other than the above (such as heating, fan, stop, cooling thermostat OFF), the drain pump control is performed by the drain detection.
- (e) Following settings can be made using the indoor function setting of the wired remote control.
  - (i) 标准 [Standard (in cooling & dry)] : Drain pump is run during cooling and dry.
  - (ii) 标准AND采暖 [Operate in standard & heating] : Drain pump is run during cooling, dry and heating.
  - (iii) 标准AND采暖AND送风 [Operate in heating & fan] : Drain pump is run during cooling, dry, heating and fan.
  - (iv) 标准AND送风 [Operate in standard & fan] : Drain pump is run during cooling, dry and fan.

Note (1) Values in [ ] are for the RC-EX3A model.

**(12) Drain pump motor (DM) control**

- (a) Drain detection switch is turned ON or OFF with the float switch (FS) and the timer.

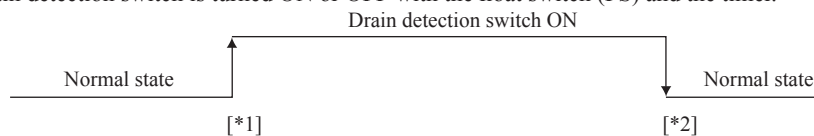

[\*1] Drain detection switch is turned “ON” when the float switch “Open” is detected for 3 seconds continuously in the drain detectable space.

[\*2] Drain detection switch is turned “OFF” when the float switch “Close” is detected for 10 seconds continuously.

- (i) It detects always from 30 seconds after turning the power ON.
  - 1) There is no detection of anomalous draining for 10 seconds after turning the drain pump OFF.
  - 2) Turning the drain detection switch “ON” causes to turn ON the drain pump forcibly.
  - 3) Turning the drain detection switch “OFF” releases the forced drain pump ON condition.
- (b) Indoor unit performs the control A or B depending on each operating condition.

	Indoor unit operation mode				
	Stop <sup>(1)</sup>	Cooling	Dry	Fan <sup>(2)</sup>	Heating
Compressor ON		Control A			
Compressor OFF		Control B			

Notes (1) Including the stop from the cooling, dehumidifying, fan and heating, and the anomalous stop  
 (2) Including the “Fan” operation according to the mismatch of operation modes

- (i) Control A
  - 1) If the float switch detects any anomalous draining condition, the unit stops with the anomalous stop (displays E9) and the drain pump starts. After detecting the anomalous condition, the drain pump motor continues to be ON.
  - 2) It keeps operating while the float switch is detecting the anomalous condition.
- (ii) Control B
 

If the float switch detects any anomalous drain condition, the drain pump motor is turned ON for 5 minutes, and at 10 seconds after the drain pump motor OFF it checks the float switch. If it is normal, the unit is stopped under the normal mode or, if there is any anomalous condition, E9 is displayed and the drain pump motor is turned ON. (The ON condition is maintained during the drain detection.)

**(13) Operation check/drain pump test run operation mode**

- (a) If the power is turned on by the DIP switch (SW7-1) on the indoor unit control PCB when electric power source is supplied, it enters the mode of operation check/drain pump test run. It is ineffective (prohibited) to change the switch after turning power on.
- (b) When the communication with the remote control has been established within 60 seconds after turning power on by the DIP switch (SW7-1) ON, it enters the operation check mode. Unless the remote control communication is established, it enters the drain pump test run mode.

Note (1) To select the drain pump test run mode, disconnect the remote control connector (CNB) on the indoor unit PCB to shut down the remote control communication.

- (c) Operation check mode  
There is no communication with the outdoor unit but it allows performing operation in respective modes by operating the remote control.
- (d) Drain pump test run mode  
As the drain pump test run is established, the drain pump only operates and during the operation protective functions by the microcomputer of indoor unit become ineffective.

**(14) Cooling, dehumidifying frost protection**

- (a) To prevent frosting during cooling mode or dehumidifying mode operation, the thermostat-OFF if the indoor heat exchanger temperature (detected with Thi-R) drops to 1.0 °C or lower at 4 minutes after the thermostat-ON. If the indoor unit heat exchanger temperature is 1.0 °C or lower after 5 minutes, the indoor unit is controlled thermostat-OFF. If it becomes 10°C or higher, the control terminates. When the indoor heat exchanger temperature has become as show, the indoor unit send outdoor unit the “Anti-frost” signal.

- Frost prevention temperature setting can be selected with the indoor unit function setting of the wired remote control.

Item	Symbol	A
Temperature - Low (Factory default)		1.0
Temperature - High		2.5

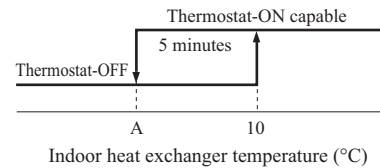

- (b) Selection of indoor fan speed  
If it enters the frost prevention control during cooling operation (excluding dehumidifying), the indoor fan speed is switched.
  - (i) When the indoor return air detection temperature (detected with Thi-A) is 18°C or higher and the indoor heat exchanger temperature (detected with Thi-R) detects the compressor frequency drop start temperature A°C+1°C, of indoor fan speed is increased by 20min<sup>-1</sup>.
  - (ii) If the phenomenon of (i) above is detected again after the acceleration of indoor fan, indoor fan speed is increased further by 20min<sup>-1</sup>.

Note (1) Indoor fan speed can be increased by up to 2 taps.

- Compressor frequency drop start temperature

Hs > 50%

Symbol \ Item	Low	High
A	1.0	2.5
B	2.5	4.0

Hs ≤ 50%

Symbol \ Item	Low	High
A	-0.5	1.0
B	1.0	2.5

Note (1) Frost prevention temperature setting can be selected with the indoor unit function setting of the wired remote control.

**(15) Heating overload protection**

- (a) If the indoor heat exchanger temperature (detected with Thi-R) at 63°C or higher is detected for 2 seconds continuously, the compressor stops. When the compressor is restarted after a 3-minute delay, if a temperature at 63°C or higher is detected for 2 seconds continuously within 60 minutes after initial detection and if this is detected 5 times consecutively, the compressor stops with the anomalous stop (E8). Anomalous stop occurs also when the indoor heat exchanger temperature at 63°C or higher is detected for 6 minutes continuously.

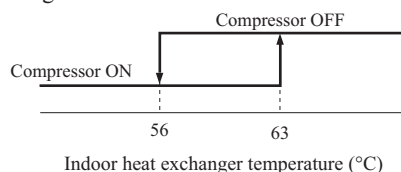

- (b) Indoor fan speed selection  
If, after second detection of heating overload protection up to fourth, the indoor fan is set at below Hi tap when the compressor is turned ON, the indoor fan speed is increased by 1 tap.

**(16) Anomalous fan motor**

- (a) After starting the fan motor, if the fan motor speed is 200 min<sup>-1</sup> or less is detected for 30 seconds continuously and 4 times within 60 minutes, then fan motor stops with the anomalous stop (E16).
- (b) If the fan motor fails to reach at -50 min<sup>-1</sup> less than the required speed, it stops with the anomalous stop (E20).

**(17) Plural unit control – Control of 16 units group by one remote control**

**(a) Function**

One remote control can control a group of multiple number of unit (Max. 16 indoor units). “Operation mode” which is set by the remote control can operate or stop all units in the group one after another in the order of unit. No.<sup>(1)</sup>. Thermostat and protective function of each unit function independently.

Note (1) Unit No. is set by SW2 on the indoor control PCB. Unit No. setting by SW2 is necessary for the indoor unit only. In cases of the twin, triple and double twin specification, it is necessary set for the master and the slave units. This can be selected by SW5. (All are set for the master unit at the shipping from factory.)

SW2: For setting of 0 – 9, A – F  
 SW5: For setting of master and slave units  
 (See table shown at right.)

Unit	Switch	
	SW5-1	SW5-2
Master unit	OFF	OFF
Slave unit a	OFF	ON
Slave unit b	ON	OFF
Slave unit c	ON	ON

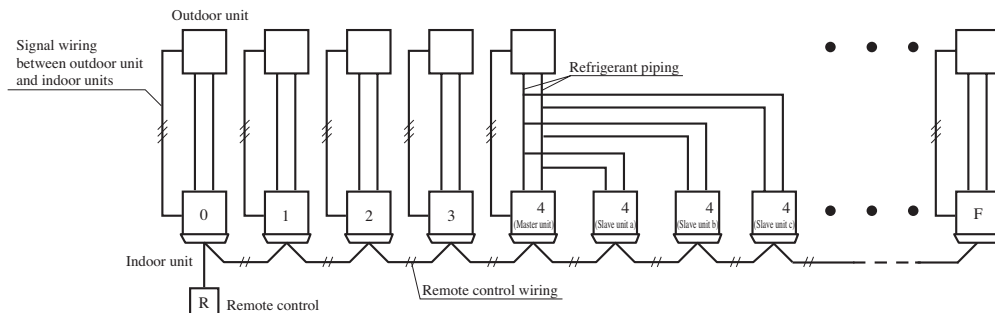

(2) Unit No. may be set at random unless duplicated, it should be better to set orderly like 0, 1, 2..., F to avoid mistake.

**(b) Display to the remote control**

- (i) Central or each remote control basis, heating preparation: the smallest unit No. among the operating units in the remote mode (or the center mode unless the remote mode is available) is displayed.
- (ii) Inspection display, filter sign: Any of unit that starts initially is displayed.

**(c) Confirmation of connected units**

- (i) In case of RC-EX3A remote control  
 If you touch the buttons in the order of “Menu” → “Service setting” → “Service & Maintenance” → “Service password” → “IU address” on the TOP screen of remote control, the indoor units which are connected are displayed.
- (ii) In case of RC-E5 remote control  
 Pressing “AIR CON No.” button on the remote control displays the indoor unit address. If “▲” “▼” button is pressed at the next, it is displayed orderly starting from the unit of smallest No.

**(d) In case of anomaly**

If any anomaly occurs on a unit in a group (a protective function operates), that unit stops with the anomalous stop but any other normal units continue to run as they are.

**(e) Signal wiring procedure**

Signal wiring between indoor and outdoor units should be made on each unit same as the normal wiring. For the group control, connect the remote control wiring to each indoor unit via terminal block for the remote control.

Connect the remote control wiring separately from the power source cable or wires of other electric devices (AC220V or higher).

**(18) High ceiling control**

When sufficient air flow rate cannot be obtained from the indoor unit which is installed at a room with high ceiling, the air flow rate can be increased by changing the fan tap. To change the fan tap, use the indoor unit function “FAN SPEED SET” on the wired remote control.

Fan tap		Indoor unit air flow setting			
FAN SPEED SET	STANDARD	P-Hi2 - Hi - Me - UL0	Hi - Me - UL0	Hi - UL0	Hi - Me
	HIGH SPEED1	P-Hi2 - P-Hi1 - Hi - Me	P-Hi1 - Hi - Me	P-Hi1 - Me	P-Hi1 - Hi
	HIGH SPEED2	P-Hi2 - Hi - Me - UL0	Hi - Me - UL0	Hi - UL0	Hi - Me

Notes (1) Factory default is STANDARD.

(2) At the hot-start and heating thermostat OFF, or other, the indoor fan is operated at the low speed tap of each setting.

(3) This function is not able to be set with wireless remote controls or simple remote control (RCH-E3)

**(19) Abnormal temperature sensor (return air/indoor heat exchanger) broken wire/short-circuit detection**

**(a) Broken wire detection**

When the return air temperature sensor detects -55°C or lower or the heat exchanger temperature sensor detect -55°C or lower for 5 seconds continuously, the compressor stops. After a 3-minute delay, the compressor restarts but, if it is detected again within 60 minutes after the initial detection for 6 minutes continuously, stops again (the return air temperature sensor: E7, the heat exchanger temperature sensor: E6).

**(b) Short-circuit detection**

If the heat exchanger temperature sensor detects short-circuit for 5 seconds continuously at 2 minutes and 20 seconds after the compressor ON during cooling operation, the compressor stops (E6).

**(20) External input/output control (CnT or CnTA)**

External input/output connectors are provided on the indoor unit control PCB, and each input/output is possible to be changed by RC-EX3A.

Be sure to connect the wired remote control to the indoor unit. Remote operation with CnT/CnTA only is not possible.

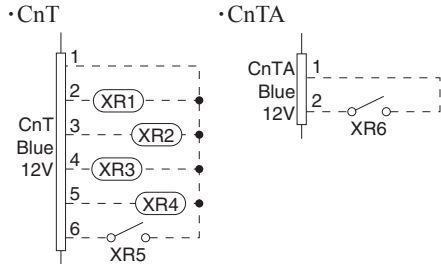

Input/Output	Connector	Factory default setting	RC-EX3A function name
Output	CnT-2 (XR1)	Operation output	External output 1
	CnT-3 (XR2)	Heating output	External output 2
	CnT-4 (XR3)	Compressor ON output	External output 3
	CnT-5 (XR4)	Inspection(Error) output	External output 4
"Input (Volt-free contact)"	CnT-6 (XR5)	Remote operation input	External input 1
	CnTA (XR6)	Remote operation input	External input 2

**Priority order for combinations of CnT and CnTA input.**

		CnTA					
		① Operation stop level	② Operation stop pulse	③ Operation permission/prohibition	④ Operation permission/prohibition pulse	⑤ Cooling/heating selection level	⑥ Cooling/heating selection pulse
CnT	① Operation stop level	CnT ①	CnT ①	CnT ① + CnTA ②	CnT ①	CnT ① / CnTA ⑤	CnT ① / CnTA ⑥
	② Operation stop pulse	CnT ②	CnT ②	CnT ② + CnTA ③	CnT ②	CnT ② / CnTA ⑤	CnT ② / CnTA ⑥
	③ Operation permission/prohibition level	CnT ③ > CnTA ①	CnT ③ > CnTA ②	CnT ③ + CnTA ③	CnT ③	CnT ③ / CnTA ⑤	CnT ③ / CnTA ⑥
	④ Operation permission/prohibition pulse	CnT ④	CnT ④	CnT ④ + CnTA ③※	CnT ④	CnT ④ / CnTA ⑤	CnT ④ / CnTA ⑥
	⑤ Cooling/heating selection level	CnT ⑤ / CnTA ①	CnT ⑤ / CnTA ②	CnT ⑤ / CnTA ③	CnT ⑤ / CnTA ④	CnT ⑤	CnT ⑤
	⑥ Cooling/heating selection pulse	CnT ⑥ / CnTA ①	CnT ⑥ / CnTA ②	CnT ⑥ / CnTA ③	CnT ⑥ / CnTA ④	CnT ⑥	CnT ⑥

Note (1) Following operation commands are accepted when the operation prohibition is set with CnTA as indicated with \*.

Individual operation command from remote control, test run command from outdoor unit and operation command from option device, CnT input.

Reference: Explanation on the codes and the combinations of codes in the table above

- In case of CnT "Number", the CnT "Number" is adopted and CnTA is invalidated.
- In case of CnTA "Number", the CnTA "Number" is adopted and CnT is invalidated.
- In case of CnT "Number"/CnTA "Number", the CnT "Number" and the CnTA "Number" become independent functions each other.
- In case of CnT "Number" + CnTA "Number", the CnT "Number" and the CnTA "Number" become competing functions each other.
- In case of CnT "Number" > CnTA "Number", the function of CnT "Number" supersedes that of CnTA "Number".
- In case of CnT "Number" < CnTA "Number", the function of CnTA "Number" supersedes that of CnT "Number".  
(The "Number" above means ① - ⑥ in the table.)

**(a) Output for external control (remote display)**

Indoor unit outputs the following signal for operation status monitoring.

	Output name	Condition
1	Operation output	During operation
2	Heating output	During heating operation
3	Compressor ON output	During compressor operation
4	Inspection(Error) output	When anomalous condition occurs.
5	Cooling output	During cooling operation
6	Fan operation output 1	When indoor unit's fan is operating
7	Fan operation output 2	When indoor unit's fan is operating, and fan speed is higher than Hi speed.
8	Fan operation output 3	When indoor unit's fan is operating, and fan speed is Lower than Me speed.
9	Defrost/oil return output	When indoor unit receive defrost/oil return signal from the outdoor unit.
10	Ventilation output	When "Venti.ON" is selected from remote control
11	Free cooling output	When the ambient temperature is between 10 - 18°C in cooling and fan operation
12	Indoor unit overload alarm output	Refer to "IU overload alarm"
13	Heater output	Refer to "(8) Thermostat operation (b) Heating"

**(b) Input for external control**

The external input for the indoor unit can be selected from the following input.

	Input name	Content
1	Run/Stop	Refer to [(20) (c) Remote operation input]
2	Permission/Prohibition	Refer to [(21) Operation permission/prohibition]
3	Cooling/Heating	Refer to [(23) Selection of cooling/heating external input function]
4	Emergency stop	Indoor/outdoor units stop the operation, and [E63] is displayed.
5	Setting temperature shift	Set temperature is shifted by +2/-2°C in cooling/heating.
6	Forced thermo-OFF	Unit goes thermo off.
7	Temporary stop	Refer to [(22) Temporary stop input]
8	Silent mode	Outdoor unit silent mode is activated.

**(i) In case of “Level input” setting (Factory default)**

Input signal to CnT-6 or CnTA is OFF→ON ..... unit ON  
 Input signal to CnT-6 or CnTA is ON→OFF ..... unit OFF  
 Operation is not inverted.

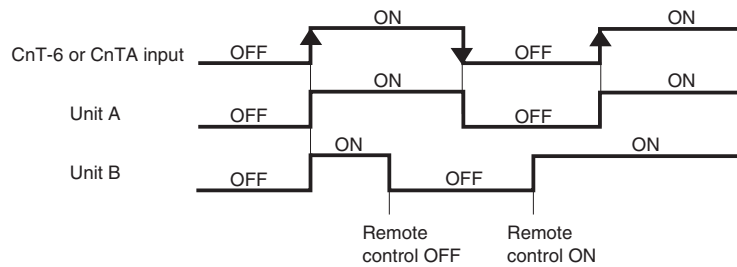

Note (1) The latest operation has priority  
 It is available to operate/stop by remote control or central control

**(ii) In case of “Pulse input” setting (Local setting)**

It is effective only when the input signal to CnT-6 or CnTA is changed OFF→ON, and at that time unit operation [ON/OFF] is inverted.

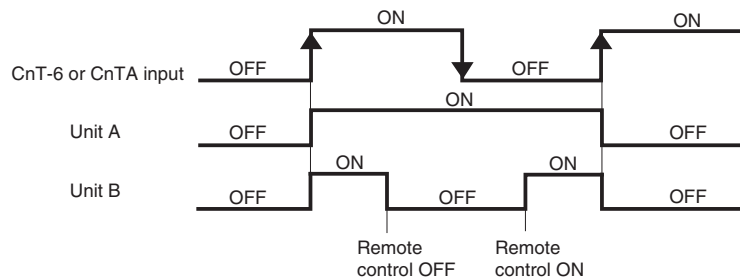

**(c) Remote operation**

**(i) In case of multiple units (Max. 16 indoor units group) are connected to one wired remote control**

When the R/C function setting of wired remote control for “External control set” is changed from “Individual (Factory default)” to “For all units”, all units connected in one wired remote control system can be controlled by external operation input.

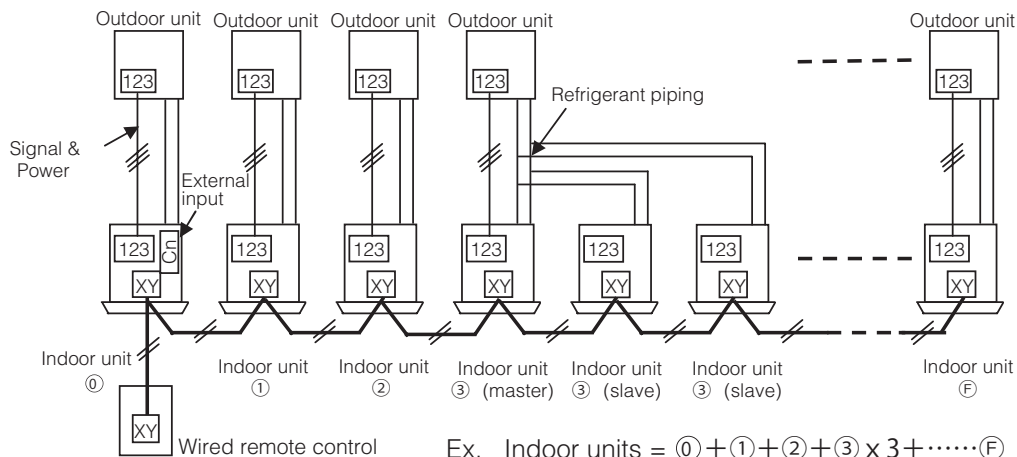

CnT-6 or CnTA	Individual operation (Factory default)		All units operation (Local setting)	
	ON	OFF	ON	OFF
	Only the unit directly connected to the remote control can be operated.	Only the unit directly connected to the remote control can be stopped operation.	All units in one remote control system can be operated.	All units in one remote control system can be stopped operation.
	Unit ① only	Unit ① only	Units ① – ㉞	Units ① – ㉞

When more than one indoor unit (Max. 16 indoor units) are connected in one wired remote control system:

- (1) With the factory default, external input to CnT-6 or CnTA is effective for only the unit ①.
- (2) When setting “For all unit” (Local setting), all units in one remote control system can be controlled by external input to CnT-6 or CnTA on the indoor unit ①.
- (3) External input to CnT-6 or CnTA on the other indoor unit than the unit ① is not effective.

**(21) Operation permission/prohibition**

**(In case of adopting card key switches or commercially available timers)**

When the indoor function setting of wired remote control for “Operation permission/prohibition” is changed from “Invalid (Factory default)” to “Valid”, following control becomes effective.

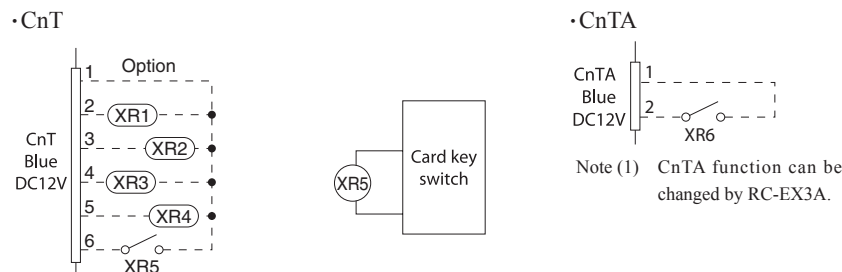

CnT-6 or CnTA	Normal operation (Factory default)		Operation permission/prohibition mode “Valid” (Local setting)	
	ON	OFF	ON	OFF
	Operation	Stop	Operation permission*1	Operation prohibition (Unit stops)

\*1 **Only the “LEVEL INPUT” is acceptable for external input**, however when the indoor function setting of “Level input (Factory default)” or “Pulse input” is selected by the function for “External input” of the wired remote control, operation status will be changed as follows.

In case of “Level input” setting	In case of “Pulse input” setting
Unit operation from the wired remote control becomes available*(1)	Unit starts operation *(2)

\* (1) In case that “Operation permission/prohibition mode” setting is “Valid” and “External input” setting is “Level input (Factory default)”;

- ① When card key switch is ON (CnT-6 or CnTA ON: Operation permission), start/stop operation of the unit from the wired remote control becomes available.
- ② When card key switch is OFF (CnT-6 or CnTA OFF: Operation prohibition), the unit stops operation in conjunction with OFF signal, and start/stop operation of the unit from the wired remote control becomes unavailable.

\* (2) In case that “Operation permission/prohibition mode” setting is “Valid” and “External input” setting is “Pulse input (Local setting)”;

- ① When card key switch is ON (Operation permission), the unit starts operation in conjunction with ON signal, and also start/stop operation of the unit from the wired remote control becomes available.
- ② When card key switch is OFF (Operation prohibition), the unit stops operation in conjunction with OFF signal, and start/stop operation of the unit from the wired remote control becomes unavailable.

(3) This function is invalid only at “Center mode” setting done by central control.

**(a) In case of CnT ① Operation stop level > CnTA ③ Operation permission/prohibition level**

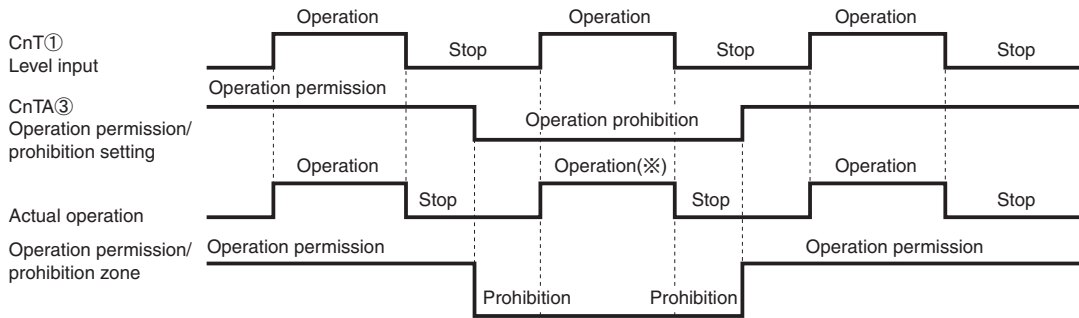

(※) CnT level input supersedes CnTA operation prohibition.

**(b) In case of CnT ③ Operation permission/prohibition level + CnTA ③ Operation permission/prohibition level**

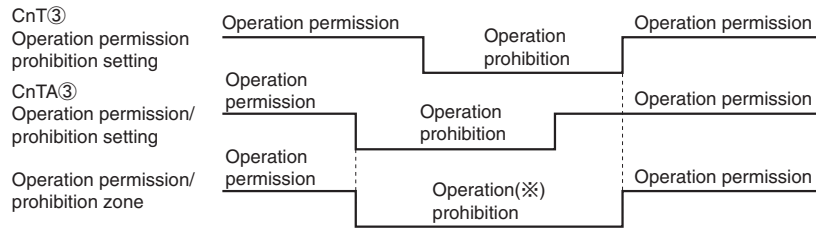

(※) Operation prohibition zone is determined by the OR judgment between CnT operation prohibition zone and CnTA operation prohibition zone.

**(c) In case of CnT ③ Operation permission/prohibition level > CnTA ② Operation/stop pulse**

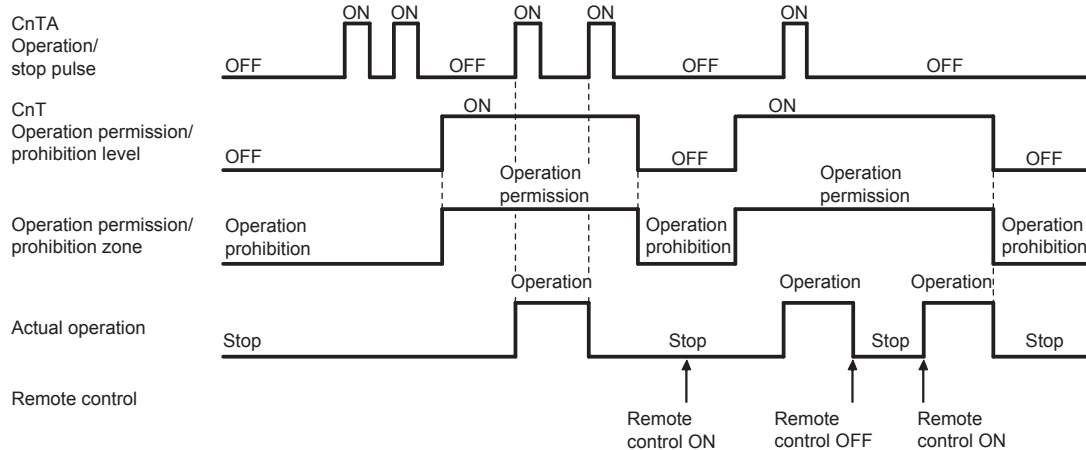

Note (1) If it is prohibited by CnT, all "Operation" and "Stop" commands are not accepted.

**(d) In case of CnT ② Operation/stop pulse + CnTA ③ Operation permission/prohibition level**

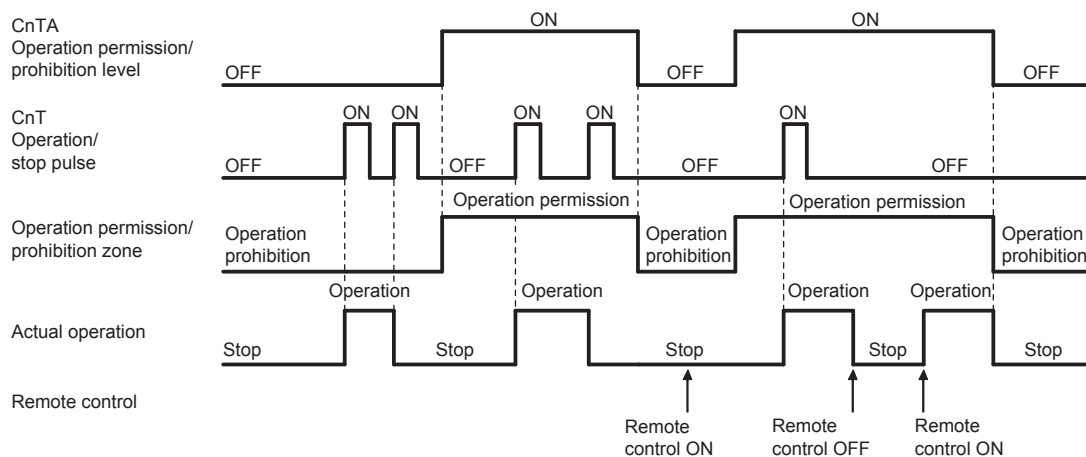



**(22) Temporary stop input**

In case of temporary stop, operation lamp of remote control lights, but indoor/outdoor unit stop the operation.

**(a) In case of “level input” setting (Factory default)**

Input signal to CnT-6 or CnTA is OFF → ON : Temporary stop  
 Input signal to CnT-6 or CnTA is OFF → ON : Normal operation

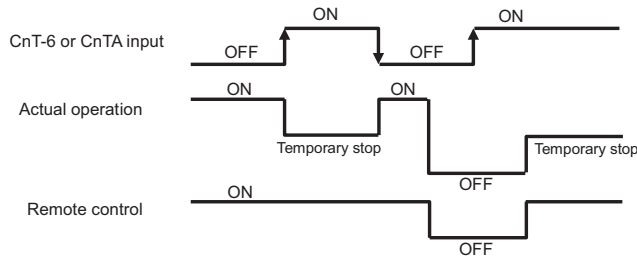

**(b) In case of “pulse input” setting (Local setting)**

It is effective only when the input signal is changed OFF→ON, and “temporary stop/normal operation” is inverted.

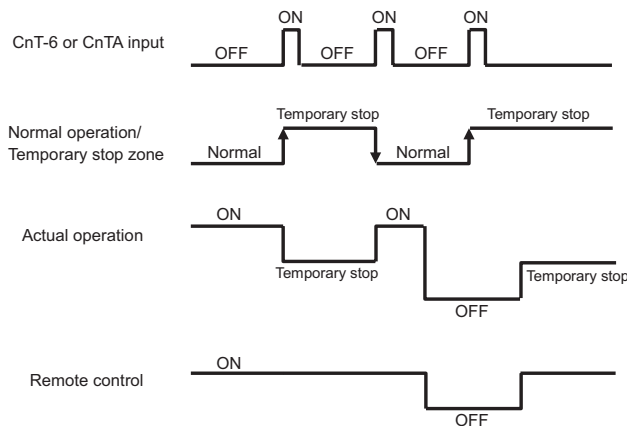

**(23) Selection of cooling/heating external input function**

- (a) When “External input 1 setting: Cooling/heating” is set by the indoor unit function from remote control, the cooling or heating is selected with CnT-6 or CnTA.
- (b) When the external input 1 method selection: Level input is set by the indoor unit function:
  - CnT-6 or CnTA: OPEN → Cooling operation mode
  - CnT-6 or CnTA: CLOSE → Heating operation mode
- (c) When the external input 1 method selection: Pulse input is set by the indoor unit function:
  - If the external input is changed OPEN → CLOSE, operation modes are inverted (Cooling → Heating or Heating → Cooling).
- (d) If the cooling/heating selection signal is given by the external input, the operation mode is transmitted to the remote control.

■ Selection of cooling/heating external input function

External input selection	External input method	Operation	
External input selection Cooling/heating selection	⑤ Level	External terminal input (CnT or CnTA)	
		Cooling/heating	
	⑥ Pulse	External terminal input (CnT or CnTA)	
		Cooling/heating	
		Cooling/heating (Competitive)	

Note (1) Regarding the priority order for combinations of CnT and CnTA, refer to page 20.

**(24) Fan control at heating startup****(a) Starting conditions**

At the start of heating operation, if the difference of setting temperature and return air temperature is 5°C or higher after the end of hot start control, this control is performed.

**(b) Contents of control**

- (i) Sampling is made at each minute and, when the indoor heat exchanger temperature (detected with Thi-R) is 37°C or higher, present number of revolutions of indoor fan speed is increased by 10min<sup>-1</sup>.
- (ii) If the indoor heat exchanger temperature drops below 37°C at next sampling, present number of revolutions of indoor fan speed is reduced by 10min<sup>-1</sup>.

**(c) Ending conditions**

Indoor fan speed is reduced to the setting air flow volume when the compressor OFF is established and at 30 minutes after the start of heating operation.

**(25) Room temperature detection temperature compensation during heating**

With the standard specification, the compressor is turned ON/OFF with the thermostat setting temperature. When the thermostat is likely to turn OFF earlier because the unit is installed at the ceiling where warm air tends to accumulate, the setting can be changed with the wired remote control indoor unit function “**SP OFFSET**”. The compressor and the heater are turned ON/OFF at one of the setting temperature +3, +2 or +1°C in order to improve the feeling of heating. The setting temperature, however, has the upper limit of 30°C.

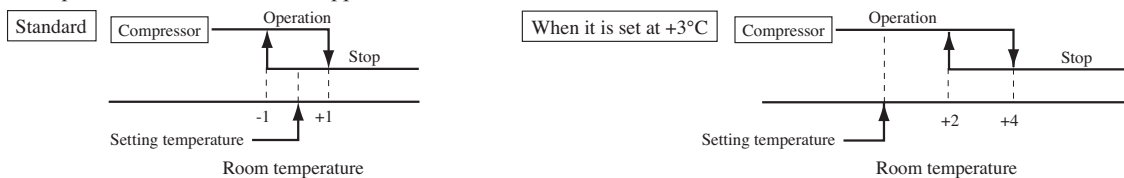
**(26) Return air temperature compensation**

This is the function to compensate the deviation between the detection temperature by the return air temperature thermistor and the measured temperature after installing the unit.

- (a) It is adjustable in the unit of 0.5°C with the wired remote control indoor unit function “RETURN AIR TEMP”.
  - +1.0°C, +1.5°C, +2.0°C
  - -1.0°C, -1.5°C, -2.0°C
- (b) Compensated temperature is transmitted to the remote control and the compressor to control them.

Note (1) The detection temperature compensation is effective on the indoor unit thermistor only.

**(27) High power operation (RC-EX3A only)**

It operates at with the set temperature fixed at 16°C for cooling, 30°C for heating and maximum indoor fan speed for 15 minutes maximum.

**(28) Energy-saving operation (RC-EX3A only)**

It operates with the setting temperature fixed at 28°C for cooling, 22°C for heating or 25°C for auto. When fan control in cooling/heating thermo-OFF setting is “Set fan speed”, fan speed during thermo-OFF is changed to “Low”. (Maximum capacity is restricted at 80%.)

**(29) Warm-up control (RC-EX3A only)**

Operation will be started 5 to 60 minutes before use according to the forecast made by the microcomputer which calculates when the operation should be started in order to warm up the indoor temperature near the setting temperature at the setting time of operation start.

**(30) Home leave mode (RC-EX3A only)**

When the unit is not used for a long period of time, the room temperature is maintained at a moderate level, avoiding extremely hot or cool temperature.

- (a) Cooling or heating is operated according to the outdoor temperature (factory setting 35°C for cooling, 0°C for heating) and the setting temperature. (factory setting 33°C for cooling, 10°C for heating)
- (b) Setting temperature and indoor fan speed can be set by RC-EX3A.

**(31) Auto temperature setting (RC-EX3A only)**

Setting temperature is adjusted automatically at the adequate temperature the center setting temperature is 24°C by correcting the outdoor air temperature.

**(32) Fan circulator operation (RC-EX3A only)**

When the fan is used for circulation, the unit is operated as follows depending on the setting with the remote control.

- (a) If the invalid is selected with the remote control, the fan is operated continuously during the fan operation. (normal fan mode)
- (b) If the valid is selected with the remote control, the fan is operated or stopped when on the difference of the remote control temperature sensor and the return air temperature sensor becomes bigger than 3°C.

**(33) The operation judgment is executed every 5 minutes (RC-EX3A only)**

Setting temperature  $T_s$  is changed according to outdoor temperature.

This control is valid with cooling and heating mode. (Not auto mode)

- (a) Operate 5 minutes forcedly.
- (b) Setting temperature is adjusted every 10 minutes.
  - (i) Cooling mode.  
 $T_s = \text{outdoor temperature} - \text{offset value}$
  - (ii) Heating mode.  
 $T_s = \text{outdoor temperature} - \text{offset value}$
- (c) If the return air temperature lower than 18°C in cooling or return air temperature becomes higher than 25°C in heating, unit goes thermostat OFF.

**(34) Auto fan speed control (RC-EX3A only)**

In order to reach the room temperature to the set temperature as quickly as possible, the air flow rate is increased when the set temperature of thermostat differs largely from the return air temperature. According to temperature difference between set temperature and return air temperature, indoor fan tap are controlled automatically.

- Auto 1: Changes the indoor fan tap within the range of Hi ↔ Me ↔ Lo.
- Auto 2: Changes the indoor fan tap within the range of P-Hi ↔ Hi ↔ Me ↔ Lo.

**(35) Indoor unit overload alarm (RC-EX3A only)**

If the following condition is satisfied at 30 minutes after starting operation, RC-EX3A shows maintenance code "M07" and the signal is transmitted to the external output (CnT-2-5).

- Cooling, Dry, Auto(Cooling) : Indoor air temperature = Set room temperature by remote control + Alarm temperature difference
  - Heating, Auto(Heating) : Indoor air temperature = Set room temperature by remote control - Alarm temperature difference
- Alarm temperature difference is selectable between 5 to 10°C.

If the following condition is satisfied or unit is stopped, the signal is disappeared.

- Cooling, Dry, Auto(Cooling) : Indoor air temperature = Set room temperature + Alarm temperature difference -2°C
- Heating, Auto(Heating) : Indoor air temperature = Set room temperature - Alarm temperature difference +2°C

**(36) Peak-cut timer (RC-EX3A only)**

Power consumption can be reduced by restricting the maximum capacity.

Set the [Start time], the [End time] and the capacity limit % (Peak-cut %).

- 4-operation patterns per day can be set at maximum.
- The setting time can be changed by 5-minutes interval.
- The selectable range of capacity limit % (Peak-cut %) is from 0% to 40-80% (20% interval).
- Holiday setting is available.

**(37) Motion sensor control (RC-EX3A and RCN-E2 only)**

The sensor determines the presence of people and the amount of activity, and the following controls are done by the motion sensor.

Following settings are necessary to activate motion sensor control.

- (a) Infrared (motion) sensor setting: Installation setting of remote control  
The indoor unit which is set to “Enable” become valid.
- (b) Infrared (motion) sensor control: Energy-saving setting of remote control  
The function which is set to “Enable” become valid.

**RC-EX3A**

TOP screen **Menu** ⇒ **Service setting** ⇒ **Installation settings** ⇒ **Service password**

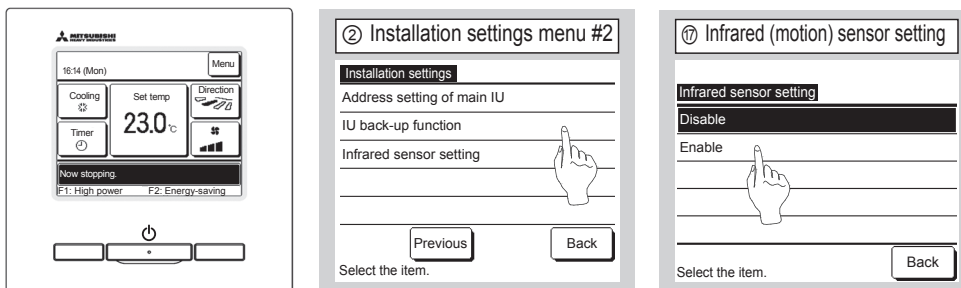

TOP screen **Menu** ⇒ **Energy-saving setting** ⇒ **Infrared sensor control** or **Motion sensor control**

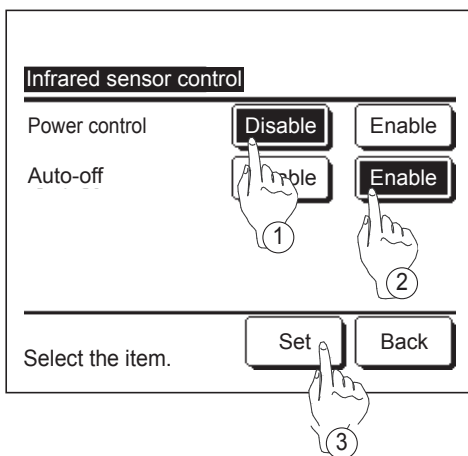

The Infrared sensor control screen and contents of the current settings are displayed.

- ① Enable/disable power control.
- ② Enable/disable auto-off.
- ③ After you set each item, tap the **Set** button.  
The display returns to the Energy-saving setting menu screen.

**RCN-E2**

**1. Set indoor functions**

- ① Press the ON/OFF button to stop the unit.
- ② Press the desired one of the buttons shown item 2. while holding down the FUNCTION SETTING switch.
- ③ Use the selection buttons, ▲ and ▼, to change the setting.
- ④ Press the SET button.  
The buzzer on the remote control signal receiver beeps twice, and the LED lamp flashes four times at two-second intervals.

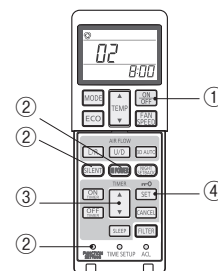

**2. Setting details**

Button	Number indicator	Function setting
SILENT	00	Infrared sensor setting (Motion sensor setting) : Disable
	01	Infrared sensor setting (Motion sensor setting) : Enable
HI POWER	00	Infrared sensor control (Motion sensor control) : Disable
	01	Infrared sensor control (Motion sensor control) : Power control only
	02	Infrared sensor control (Motion sensor control) : Auto OFF only
	03	Infrared sensor control (Motion sensor control) : Power control and Auto OFF

(i) Power saving / comfort control

The set temperature is adjusted according to the presence of people and their amount of activity detected by the infrared (motion) sensor.

MODE:AUTO/COOL/HEAT mode operation

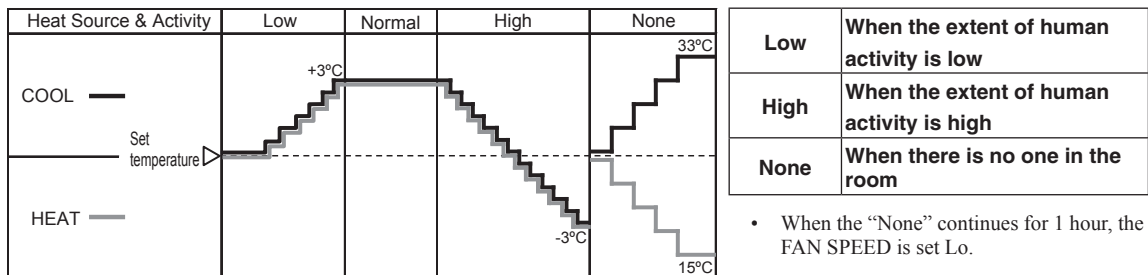

Notes (1) When the following operations are set, power saving control will be canceled.

- ① Energy-saving, Home leave mode, Warm-up control, Cooling operation check.
- ② When the operation mode is changed DRY or FAN.

(2) Not operable while the air-conditioner is OFF.

(ii) Auto-off control

When no activity is detected for 1 hour, unit will go stand-by mode.※ Unit will re-start operation automatically with the original set temperature by activity detection during the stand-by mode. When stand-by mode continues for 12 hours, unit stops.

※ Compressor keeps stopped regardless of the set temperature.

### 1.1.4 Operation control function by the outdoor control

#### Models FDC71-140

##### (1) Determination of compressor speed (Frequency)

##### Required frequency

##### (a) Cooling/dehumidifying operation

Unit: rps

Model		FDC71	FDC100	FDC125	FDC140
Max. required frequency	Usual operation	88	75	95(92)	95(92)
	Silent mode, outdoor air temperature $\leq 15^{\circ}\text{C}$	80	50	60	70
Min. required frequency		20	20	20	20

Note (1) Value in ( ) are for the 3 phase models.

##### (b) Heating operation

Unit: rps

Model		FDC71	FDC100	FDC125	FDC140
Max. required frequency	Usual operation	112	100	120	120
	Silent mode	90	60	70	70
Min. required frequency		20	20	20	20

(c) If the indoor fan speed becomes “Me” or “Lo”, Max required frequency goes down accordingly depending on indoor unit model.

(d) Max. required frequency under high outdoor air temperature in cooling mode.

Maximum required frequency is selected according to the outdoor air temperature (Tho-A).

Unit: rps

Model		FDC71	FDC100	FDC125	FDC140
Max. required frequency	Outdoor air temperature is $40^{\circ}\text{C}$ or higher	76	75	75	75
	Outdoor air temperature is $46^{\circ}\text{C}$ or higher	62	70	70	70

(e) Max. required frequency under outdoor air temperature in heating mode.

Maximum required frequency is selected according to the outdoor air temperature (Tho-A).

Unit: rps

Model		FDC71	FDC100	FDC125	FDC140
Max. required frequency	Outdoor air temperature is $18^{\circ}\text{C}$ or higher	76	75	80	85

(f) Selection of max. required frequency by heat exchanger temperature.

(i) Maximum required frequency is selected according to the outdoor heat exchanger temperature (Tho-R) during cooling/dehumidifying or according to the indoor heat exchanger temperature (Thi-R) during heating mode.

(ii) When there are 3 indoor heat exchanger temperatures (Thi-R), whichever the highest applies,

Unit: rps

Model			FDC71	FDC100	FDC125	FDC140
Max. required frequency	Cooling/dehumidifying	Outdoor heat exchanger temperature is $56(61)^{\circ}\text{C}$ or higher	60	75	95 [92]	95 [92]
	Heating	Indoor heat exchanger temperature is $56(61)^{\circ}\text{C}$ or higher	60	100	100	100

Notes (1) Value in ( ) are for the FDC71 model.

(2) Value in [ ] are for the 3 phase models.

(g) When any of the controls from (a) to (f) above may duplicate, whichever the smallest value among duplicated controls is taken as the maximum required frequency.

(h) During heating, it is operated with the maximum required frequency until the indoor heat exchanger temperature becomes  $40^{\circ}\text{C}$  or higher.

##### (2) Compressor start control

(a) Compressor starts upon receipt of the thermostat ON signal from the indoor unit.

(b) However, at initial start after turning the power source breaker, it may enter the standby state for maximum 30 minutes (“ PREPARATION” is displayed on the remote control) in order to prevent the oil loss in the compressor.

If the cooling/dehumidifying/heating operation is selected from the remote control when the outdoor unit is in the standby state, “ PREPARATION” is displayed for 3 seconds on the remote control.

**(3) Compressor soft start control****(a) Compressor protection start I**

[Control condition] Normally, the compressor operation frequency is raised in this start pattern.

[Control contents] (i) Starts with the compressor's target frequency at **A** rps.

However, when the outdoor air temperature (Tho-A) is 35°C or higher during cooling/dehumidifying or the indoor return air temperature (Thi-A) is 25°C or higher during heating, it starts at **C** rps.

(ii) At 30 seconds after the start of compressor, its target frequency changes to **B** rps and the compressor is operated for 2 - 4 minutes with its operation frequency fixed at **B** rps.

Model	Operation mode	<b>A</b> rps	<b>B</b> rps	<b>C</b> rps
FDC71	Cooling/Dehumidifying	42	42	40
	Heating	62	62	40
FDC100	Cooling/Dehumidifying	45	45	25
	Heating	45	45	25
FDC125, 140	Cooling/Dehumidifying	45	45	25
	Heating	45	45	25

**(b) Compressor protection start III**

[Control condition] Number of compressor starts is only 1 counted after the power source breaker ON.

[Control contents] Operates by selecting one of following start patterns according to the operation mode and the outdoor air temperature (Tho-A).

**(i) Low frequency operation control during cooling/dehumidifying**

[Control condition] Upon establishing the conditions of compressor protection start III, the low frequency operation control is performed during cooling/dehumidifying.

[Control contents] 1) Starts with the compressor's target frequency at **A** rps. When the outdoor air temperature (Tho-A) is 35°C or higher, it starts at **C** rps.

2) At 30 seconds after the compressor start, the compressor's target frequency is changed to **B** rps and the compressor's operation frequency is fixed for 10 minutes.

Model	Operation mode	<b>A</b> rps	<b>B</b> rps	<b>C</b> rps
FDC71	Cooling/Dehumidifying	42	42	40
FDC100	Cooling/Dehumidifying	45	45	25
FDC125, 140	Cooling/Dehumidifying	45	45	25

**(ii) Low frequency operation control during heating**

[Control condition] When the conditions of compressor protection start III are established and one of following conditions 1) is satisfied, the low number of revolutions operation control is performed during heating.

1) At 30 minutes or more after turning the power source breaker on.

[Control contents] 1) Starts the compressor with its target frequency at **A** rps. However, when the indoor return air temperature (Thi-A) is 25°C or higher, it start at **C** rps.

2) At 30 seconds after the start of compressor, the compressor's target frequency is changed to **B** rps and the compressor's operation frequency is fixed for 10 minutes.

Model	Operation mode	<b>A</b> rps	<b>B</b> rps	<b>C</b> rps
FDC71	Heating	42	42	40
FDC100	Heating	45	45	25
FDC125, 140	Heating	45	45	25

**(4) Outdoor fan control**

**(a) Outdoor fan tap and fan motor speed**

Unit: min<sup>-1</sup>

Model	Mode	Fan motor tap						
		① speed	② speed	③ speed	④ speed	⑤ speed	⑥ speed	⑦ speed
FDC71	Cooling/Dehumidifying	200	400	600	710	810	850	950
	Heating	200	400	600	710	810	850	950
FDC100	Cooling/Dehumidifying	200	370	560	640	745	870	910
	Heating	200	370	560	650	830	870	910
FDC125, 140	Cooling/Dehumidifying	200	370	560	640	745	870	910
	Heating	200	370	560	650	830	870	910

**(b) Fan tap control during cooling/defumidifying operation**

Fan taps are selected depending on the outdoor heat exchanger temperature (Tho-R1, R2) and the outdoor air temperature (Tho-A).

Note (1) It is detected by Tho-R1 or R2, whichever the higher.

• Silent mode only

	(A) zone	(B) zone	(C) zone	(D) zone
(a) zone	Tap 5(6)	Tap 5(6)	Tap 5(6)	Tap 4
(b) zone	Tap 5(6)	Tap 5(6)	Tap 4(6)	Tap 3
(c) zone	Tap 4	Tap 4	Tap 3	Tap 2
(d) zone	Tap 3	Tap 3	Tap 2	Tap 1

	(A) zone	(B) zone	(C) zone	(D) zone
(a) zone	Tap 5	Tap 5	Tap 5	Tap 4
(b) zone	Tap 5	Tap 5	Tap 3	Tap 3
(c) zone	Tap 4	Tap 3	Tap 3	Tap 2
(d) zone	Tap 3	Tap 3	Tap 2	Tap 1

Note (1) Value in ( ) are for the model FDC71.

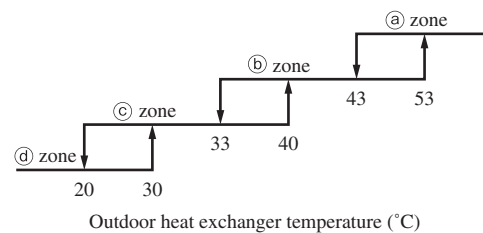
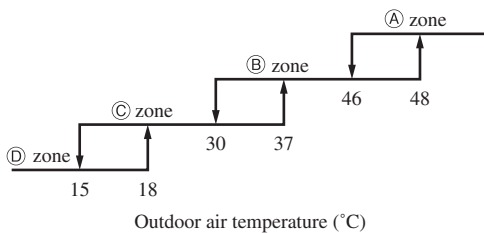

**(c) Fan tap control during heating operation**

Fan taps are selected depending on the outdoor heat exchanger temperature (Tho-R1, R2) and the outdoor air temperature (Tho-A).

Note (1) It is detected by Tho-R1 or R2, whichever the lower.

• Silent mode only

	(A) zone	(B) zone	(C) zone
(a) zone	Tap 3	Tap 3	Tap 4
(b) zone	Tap 3	Tap 4(5)	Tap 5
(c) zone	Tap 4	Tap 5	Tap 6

	(A) zone	(B) zone	(C) zone
(a) zone	Tap 3	Tap 3	Tap 3
(b) zone	Tap 3	Tap 3	Tap 5
(c) zone	Tap 4	Tap 5	Tap 6

Note (1) Value in ( ) is for the model FDC71.

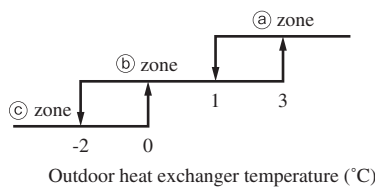
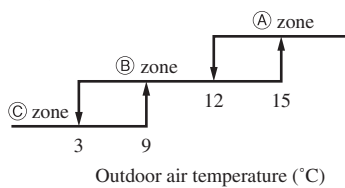

**(d) Outdoor fan control at cooling low outdoor air**

- (i) When all the following conditions are established after the start of compressor, the following control is implemented. If the outdoor air temperature (Tho-A) is in the zone (B) in the cooling/dehumidifying mode, it has elapsed 20 seconds from the start of outdoor fan and the outdoor fan is at the tap 1 speed, the outdoor fan speed is controlled according to the outdoor heat exchanger temperature (Tho-R1, R2).

Note (1) It is detected with Tho-R1 or R2, whichever the higher.

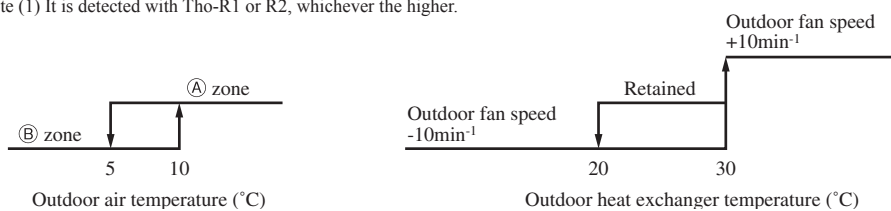



- (ii) The outdoor heat exchanger temperature is detected always and, when the number of revolutions of the outdoor fan speed has been increased or decreased, there is no change of fan speed for 20 seconds.
- (iii) Range of the outdoor fan speed under this control is as follows.
  - 1) Lower limit: 130min<sup>-1</sup>
  - 2) Upper limit: 500min<sup>-1</sup>
- (iv) As any of the following conditions is established, this control terminates.
  - 1) When the outdoor air temperature is in the zone ① and the outdoor heat exchanger temperature at 30°C or higher is established for 40 seconds or more continuously.
  - 2) When the outdoor fan speed is 500min<sup>-1</sup> and the outdoor heat exchanger temperature at 30°C or higher is established for 40 seconds or more continuously.
  - 3) When the outdoor heat exchanger temperature at 45°C or higher is established for 40 seconds or more.

**(e) Outdoor fan control by the power transistor radiator fin temperature**

When all the following conditions are established later than 3 minutes after the start of compressor, the following control is implemented.

- (i) Cooling/dehumidifying
  - 1) Outdoor air temperature (Tho-A) ≥ 33°C
  - 2) Compressor’s actual frequency ≥ **A** rps
  - 3) Power transistor radiator fin temperature ≥ **C** °C
- (ii) Heating
  - 1) Outdoor air temperature (Tho-A) ≥ 16°C
  - 2) Compressor’s actual frequency ≥ **B** rps
  - 3) Power transistor radiator fin temperature ≥ **C** °C
- (iii) Control contents
  - 1) Raises the outdoor fan tap by 1 tap.
  - 2) When the sampling is for 60 minutes and the value of power transistor radiator fin temperature (Tho-P) is as follows.
    - a) When the power transistor radiator fin temperature (Tho-P) ≥ **C** °C, the outdoor fan tap is raised by 1 speed further.
    - b) When **C** °C > power transistor radiator fin temperature (Tho-P) ≥ **D** °C, present outdoor fan tap is maintained.
    - c) When the power transistor radiator fin temperature (Tho-P) ≥ **D** °C, the outdoor fan tap is dropped by 1 speed.
- (iv) Ending conditions
 

When the operation under the condition of item 2), c) above and with the outdoor fan tap, which is determined by the item (b) is detected 2 times consecutively.

  - Compressor’s frequency and power transistor radiator fin temperature

Model \ Item	A	B	C	D
FDC71	60	70	80	75
FDC100	65	65	72	68
FDC125, 140	65	65	72	68

**(f) Caution at the outdoor fan start control (3 phase model only)**

When the outdoor fan is running at 400min<sup>-1</sup> before operating the compressor, it may operate with the compressor only, without starting up the outdoor fan this is normal.

**(g) Snow protection fan control**

If the DIP switch (SW3-2) on the outdoor control PCB is turned ON, the outdoor fan is operated for 30 seconds at 4 tap speed once in every 10 minutes depending on the outdoor air temperature (detected with Tho-A) in the stop mode or anomalous stop mode.

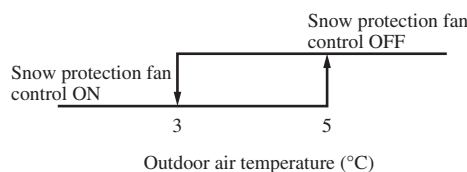

**(5) Defrost operation**

**(a) Starting conditions**

If all of the following defrost conditions A or conditions B are satisfied, the defrost operation starts.

- (i) Defrost conditions A
  - 1) Cumulative compressor operation time after the end of defrost operation has elapsed 37 [45] minutes, and the cumulative compressor operation time after the start of heating operation (remote control ON) has elapsed 30 minutes.
  - 2) After 5 minutes from the compressor ON
  - 3) After 5 minutes from the start of outdoor fan
  - 4) After satisfying all above conditions, if temperatures of the outdoor heat exchanger temperature sensor (Tho-R1, R2) and the outdoor air temperature sensor (Tho-A) become lower than the defrost operation starting temperature as shown by the right figure for 15 seconds continuously, or the suction gas saturation temperature (SST) and the outdoor air temperature (Tho-A), which are obtained from the value detected by the low pressure sensor (LPT) stay for 3 minutes within the range below the defrost operation start temperature as shown by the right figure. However, it excludes for 10 minutes after the start of compressor and the outdoor air temperature is as shown by the lower figure.

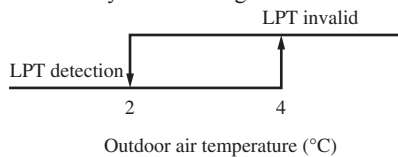

Note (1) Figures in [ ] is for model FDC71.

- (ii) Defrost conditions B
  - 1) When previous defrost ending condition is the time out of defrost operation and it is in the heating operation after the cumulative compressor operation time after the end of defrost operation has become 30 minutes.
  - 2) After 5 minutes from the start of compressor
  - 3) After 5 minutes from the start of outdoor fan

**(b) Ending conditions**

When any of the following conditions is satisfied, the heating operation starts.

- (i) When it has elapsed 8 minutes and 20 seconds after the start of defrost operation. (After 10 minutes and 20 seconds for model FDC71)
- (ii) When the outdoor heat exchanger temperatures (Tho-R1, R2), whichever the lower, becomes 12°C (model FDC71: 16°C) or higher for 10 seconds continuously.

**Model FDC71-140**

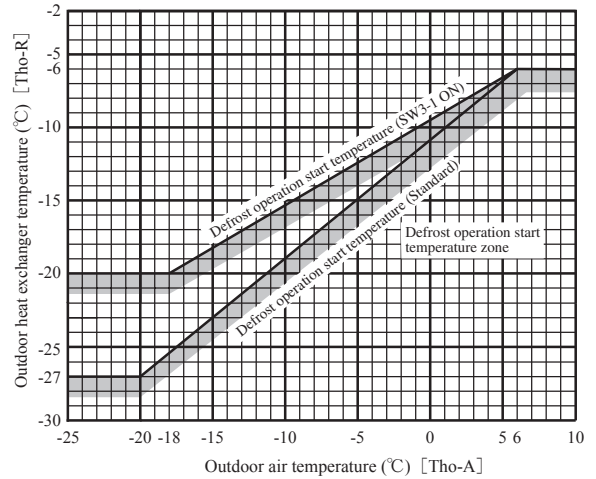

**Model FDC71**

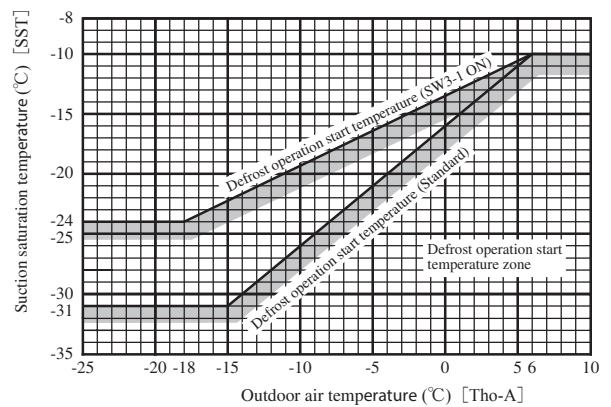

**Model FDC100-140**

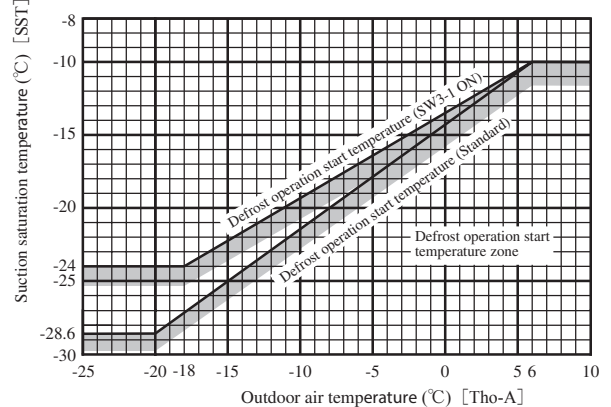

**(c) Switching of defrost control with SW3-1**

- (i) If SW3-1 on the outdoor control PCB is turned to ON, it becomes easier to enter the defrost operation. Use this when installing a unit at snowing regions.
  - (ii) Control contents
    - 1) It allows entering the defrost operation under the defrost condition A when the cumulative heating operation time becomes 30 minutes. It is 37 [45] minutes at SW3-1 OFF (Factory default).
    - 2) It allows entering the defrost operation under the defrost condition B when the cumulative heating operation time becomes 25 minutes. It is 30 minutes at SW3-1 OFF (Factory default).
    - 3) It allows the defrost operation with the outdoor heat exchanger temperature (Tho-R) and suction pressure saturation temperature (SST) being higher than normal.
- Note (1) Figures in [ ] is for model FDC71.

**(6) Protective control/anomalous stop control by compressor's number of revolutions**

**(a) Compressor discharge pipe temperature protection**

- (i) Protective control  
As the discharge pipe temperature (detected with Tho-D) exceeds the setting value, the compressor speed (frequency) is controlled to suppress the rise of discharge pipe temperature.

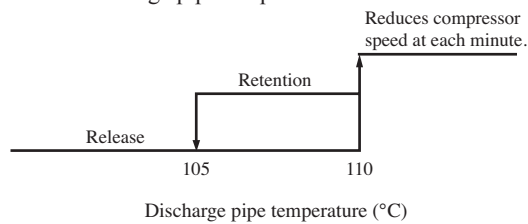

- (ii) Anomalous stop control

- 1) If the discharge pipe temperature (detected with Tho-D) exceeds the setting value, the compressor stops.
- 2) When it is detected 2 times within 60 minutes or after continuous 60 minutes, including the stop of compressor, E36 is displayed on the remote control and it enters the anomalous stop mode.

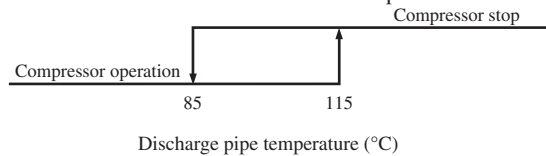

- (iii) Reset of anomalous stop mode

As it drops to the reset value of 85°C or lower for 45 minutes continuously, it becomes possible to restart from the remote control.

**(b) Cooling high pressure protection**

- (i) Protective control
  - 1) When the outdoor air temperature (Tho-A) is 40°C or higher and the outdoor heat exchanger temperature (Tho-R) exceeds the setting value, the compressor speed (frequency) is controlled to suppress the rise of high pressure.
  - 2) Control value A is updated to an optimum value automatically according to the operating conditions.

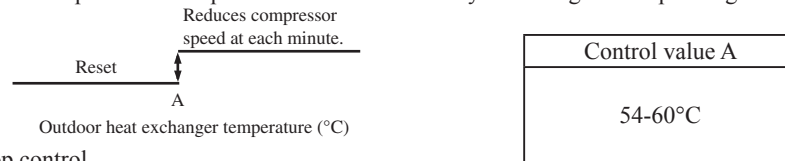

- (ii) Anomalous stop control

- 1) As the outdoor heat exchanger temperature (Tho-R) exceeds the setting value, the compressor stops.
- 2) If it is detected 5 times within 60 minutes or 65°C or higher continues for 60 minutes, including the stop of compressor, E35 is displayed on the remote control and it enters the anomalous stop mode.

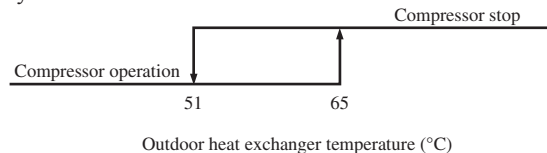

- (iii) Reset of anomalous stop mode

As it reaches the reset value of 51°C or lower, it becomes possible to restart from the remote control.

**(c) Heating high pressure protection**

- (i) Protective control
  - 1) As the indoor heat exchanger temperature (Thi-R) exceeds the setting value, the compressor speed (frequency) is controlled to suppress the rise of high pressure.
  - 2) Control value A is updated to an optimum value automatically according to the operating conditions.

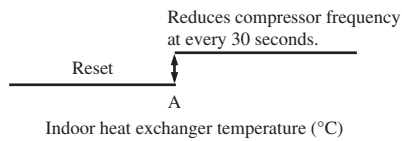

Model	Existing piping adaptation switch: SW5-1 (SW8-1: model FDC71)	
	OFF (Shipping)	ON
FDC71	52-58	46-52
FDC100-140	48-54	

Note (1) Adaptation to existing piping is at ON.

- (ii) Anomalous stop control  
Operation control function by the indoor unit control - See the heating overload protection, page 18.
- (iii) Adaptation to existing piping, stop control  
If the existing piping adaptation switch, SW5-1 (model FDC71: SW8-1), is turned ON, the compressor stops to protect existing piping when the indoor heat exchanger temperature (Thi-R) exceeds the setting value.

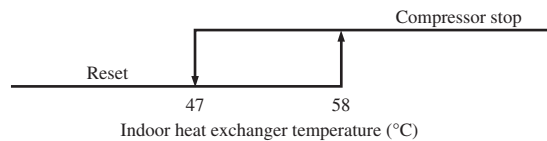

**(d) Anomaly detection control by the high pressure switch (63H1)**

- (i) If the pressure rises and operates the high pressure switch (opens at 4.15MPa/closes at 3.15MPa), the compressor stops.
- (ii) Under any of the following conditions, E40 is displayed and it enters the anomalous stop mode.
  - 1) When it occurs 5 times within 60 minutes that pressure rises and the compressor is stopped by 63H1.
  - 2) When 63H1 has been in the open state for 60 minutes continuously, including the stop of compressor.

**(e) Low pressure control**

- (i) Protective control  
If the value detected by the low pressure sensor (LPT) exceeds the setting value, the compressor speed (frequency) is controlled to restrain the drop of pressure.

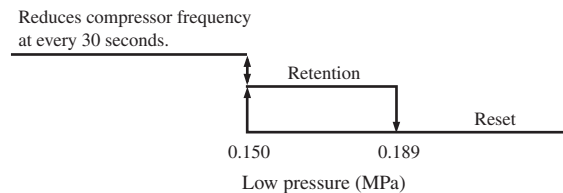

- (ii) Anomalous stop control
  - 1) When a value detected by the low pressure sensor (LPT) satisfies any of the following conditions, the compressor stops to run for its protection.
    - a) When the low pressure drops to 0.079MPa or under for 15 seconds continuously.
    - b) At 10 minutes after the start of compressor, the suction overheat becomes 30°C and the low pressure becomes 0.15MPa or under for 60 seconds continuously.
  - 2) E49 is displayed under any of the following conditions and it enters the anomalous stop mode.
    - a) When the low pressure drops 3 times within 60 minutes and the compressor stops under any of the above conditions.
    - b) When a value detected with the low pressure sensor becomes 0.079MPa or under for 5 minutes, including the stop of compressor.
  - 3) However, when the control condition 1). a) is established during the compressor protection start III, E49 is displayed at initial stop and it enters the anomalous stop mode.

**(f) Compressor pressure ratio protection control (Model FDC100 - 140 only)**

- (i) During heating operation, if the indoor heat exchanger temperature (Thi-R) and low pressure sensor (LPT) exceed the setting values at 10 minutes after the start of compressor, the compressor speed (frequency) is controlled to protect the compressor.
- (ii) This control is not performed during the outdoor fan ON and for 10 minutes from the start of outdoor fan.
- (iii) This control is not performed during defrost operation and at 10 minutes after the reset of defrost operation.
- (iv) When there are 2 indoor heat exchanger temperatures (Thi-R), the highest temperature is detected.

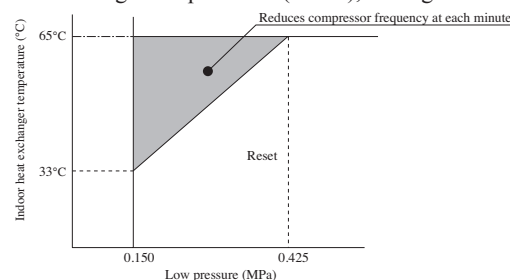

**(g) Over-current protection current safe controls I, II**

Detecting the outdoor inverter input (primary) current and the output (secondary) current, if the current values exceed setting values, the compressor speed (frequency) is controlled to protect the inverter.

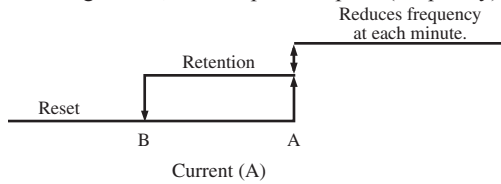

Model	Cooling		Heating		
	Control value A	Reset value B	Control value A	Reset value B	
Primary current side	FDC71	15.0	14.0	16.0	15.0
	FDC100	11.0 (23.0)	10.0 (22.0)	11.0 (23.0)	10.0 (22.0)
	FDC125, 140	11.0 (23.0)	10.0 (22.0)	11.0 (25.0)	10.0 (24.0)
Secondary current side	FDC71	13.0	12.0	13.0	12.0
	FDC100	11.5 (Fig.C)	10.5 (Fig.C)	11.5 (Fig.C)	10.5 (Fig.C)
	FDC125, 140	11.5 (Fig.C)	10.5 (Fig.C)	11.5 (Fig.C)	10.5 (Fig.C)

(Fig. C) The control value "A" and the reset value vary depending on the compressor speed.

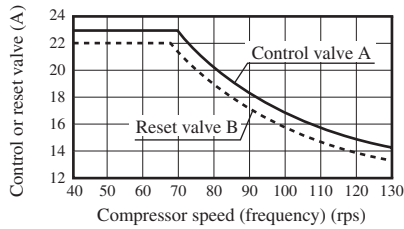

Note (1) Value in ( ) are for the single phase models.

**(h) Power transistor temperature protection**

(i) Protective control

If the power transistor temperature (detected with TIP) exceeds the setting value, the compressor speed (frequency) is controlled to suppress the rise of power transistor temperature.

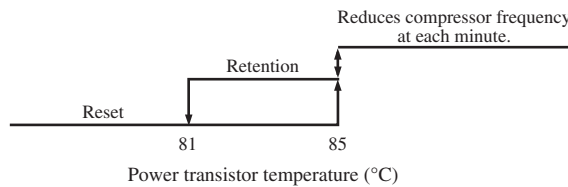

**(i) Anomalous power transistor current**

- (i) Prevents over-current on the inverter. If the current value in the power transistor exceeds the setting value, the compressor stops.
- (ii) If the current value in the power transistor exceeds the specified value and the compressor stops 4 times within 30 minutes, E42 is displayed on the remote control and it enters the anomalous stop mode.

**(j) Anomalous inverter PCB**

If the power transistor detects any anomaly for 15 minutes, including the stop of compressor, E51 is displayed on the remote control and it enters the anomalous stop mode.

**(k) Anti-frost control by the compressor frequency control**

- (i) If the indoor heat exchanger temperature (detected with Thi-R) exceeds the setting value at 4 minutes after the start of compressor, the compressor speed (frequency) is controlled to initiate the anti-frost control of indoor heat exchanger.
- (ii) When there are 2 indoor heat exchanger temperatures (Thi-R), the lowest temperature is detected.

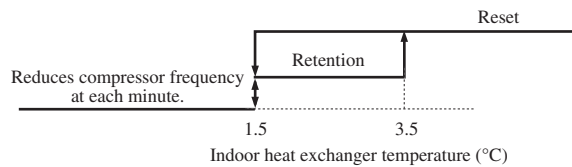

- (iii) Regarding the anti-frost control by the operation stop, refer to the operation control function by the indoor control and the cooling, dehumidifying frost prevention of page 18.

**(l) Dewing prevention control**

[Control condition]

During cooling and dehumidifying operation, if all the following conditions are established, the compressor speed (frequency) is reduced to prevent dewing and water splash.

- (i) Cooling electronic expansion valve aperture (EEVC) is 500 pulses.
- (ii) Suction overheat is 10°C or higher.
- (iii) Compressor speed (frequency) is **A** rps or higher.

[Control contents]

- (i) When the suction overheat is 10°C or higher, the compressor speed (frequency) is reduced at each 1 minute.
- (ii) Compressor speed (frequency) does not rise till the cooling expansion valve becomes 460 pulses.

Model	<b>A</b> rps
FDC71	42
FDC100-140	60

- (iii) This control takes **A** rps as its lower limit so that compressor speed is not controlled when it is less than **A** rps.

**(m) Refrigerant quantity shortage protection**

Under the compressor protection start III control during cooling and dehumidifying operations, the following control is performed by detecting the indoor heat exchanger temperature (Thi-R) and the indoor return air temperature (Thi-A).

[Control condition]

When the state that the indoor heat exchanger temperature (Thi-R) does not become lower than the indoor return air temperature (Thi-A) by 4°C or more continues for 1 minute.

[Control contents]

It judges that the flowing of refrigerant in to the indoor unit is insufficient so that the compressor is stopped and E57 is displayed on the remote control.

**(n) Broken wire detection on temperature sensor and low pressure sensor**

- (i) Outdoor heat exchanger sensor, outdoor air temperature sensor and low pressure sensor

If the following is detected for 5 second continuously within 2 minutes to 2 minutes and 20 seconds after the compressor ON, the compressor stops. After a delay of 3 minutes, it restarts but, if the same is detected repeatedly 3 times within 40 minutes, the compressor stops with the anomalous stop.

Note (1) During defrost operation and for 3 minutes after the end of defrost operation, it is not detected.

- Outdoor heat exchanger temperature sensor: -50°C or lower
- Outdoor air temperature sensor: -45°C or lower
- Low pressure sensor: 0V or under or 4.0V or over

- (ii) Discharge pipe temperature sensor, suction pipe temperature sensor

If the following is detected for 5 seconds continuously within 10 minutes to 10 minutes and 20 seconds after the compressor ON, the compressor stops. After a delay of 3 minutes, it restarts but, if the same is detected repeatedly 3 times within 40 minutes, the compressor stops with the anomalous stop.

Note (1) During defrost operation and for 3 minutes after the end of defrosting, it is not detected.

- Discharge pipe temperature sensor: -10°C or lower
- Suction pipe temperature sensor: -50°C or lower

**(o) Fan motor error**

- (i) If the fan speed of 100min<sup>-1</sup> or under is detected for 30 seconds continuously under the outdoor fan control (with the operation command of fan tap at ① speed or higher), the compressor stops.
- (ii) When the fan motor speed drops to 100min<sup>-1</sup> or under 5 times within 60 minutes and the compressor stops, it enters the anomalous stop mode with E48 displayed on the remote control.

**(p) Anomalous stop by the compressor start stop**

- (i) When it fails to shift to the compressor DC motor's rotor position defection operation at 5 seconds after establishing the compressor starting condition, the compressor stops temporarily and restarts 3 minutes later.
- (ii) If it fails to shift to the position detection operation again at second time, it judges the anomalous compressor start and stops the compressor by the anomalous stop (E59).

**(7) Silent mode**

- (a) As “Silent mode start” signal is received from the remote control, it operates by dropping the outdoor fan tap and the compressor speed (frequency).
- (b) For details, refer to items (1) and (4) above.

**(8) Test run**

- (a) It is possible to operate from the outdoor unit using the DIP switch on the outdoor unit control PCB.

SW3-3 (SW5-3)	ON	SW3-4 (SW5-4)	OFF	Cooling test run
			ON	Heating test run
	OFF	Normal and end of test run		

Make sure to turn SW3-3 (SW5-3) to OFF after the end of operation.

Note (1) Value in ( ) are for the model FDC71.

**(b) Test run control**

- (i) Operation is performed at the maximum compressor speed (frequency), which is determined for each model.
- (ii) Each protective control and error detection control are effective.
- (iii) If SW3-4 (SW5-4) is switched during test run, the compressor is stopped for once by the stop control and the cooling/heating operation is switched.  
Note (1) Value in ( ) is for the model FDC71.
- (iv) Setting and display of remote control during test run

Mode \ Item	Contents of remote control setting/display
Cooling test run	Setting temperature of cooling is 5°C.
Heating test run	Setting temperature of heating (preparation) is 30°C.

**(9) Pump-down control**

Turning ON the pump-down switch SW1 (SW9) for 2 seconds during the operation stop or anomalous stop (excluding the thermostat OFF), the pump-down operation is performed. (This is invalid when the indoor unit is operating. This is effective even when the indoor unit is stopped by the anomalous stop or the power source is turned OFF.)

Note (1) Value in ( ) is for the model FDC71.

**(a) Control contents**

- (i) Close the service valve at the liquid side. (It is left open at the gas side.)
- (ii) Compressor is started with the target speed (frequency) at FDC71:62, FDC100. 125, 140:45 rps in the cooling mode.
- (iii) Red and green lamps (LED) flash continuously on the outdoor unit control PCB.
- (iv) Each of protection and error detection controls, excluding the low pressure control, anti-frost control and dewing prevention control, is effective.
- (v) Outdoor fan is controlled as usual.
- (vi) Electronic expansion valve is fully opened.

**(b) Control ending conditions**

Stop control is initiated depending on any of the following conditions.

- (i) Low pressure of 0.087MPa or lower is detected for 5 seconds continuously.
  - 1) Red LED: Light, Green LED: Flashing, Remote control: Displays stop.
  - 2) It is possible to restart when the low pressure is 0.087MPa or higher.
  - 3) Electronic expansion valve (cooling/heating) is kept fully open.
- (ii) Stop by the error detection control
  - 1) Red LED: Keeps flashing, Green LED: Flashing
  - 2) Restart is prohibited. To return to normal operation, reset the power source.
  - 3) Electronic expansion valve (cooling/heating) is left fully open.
- (iii) When the cumulative operation time of compressor under the pump-down control becomes 5 minutes.
  - 1) Red LED: Stays OFF, Green LED: Flashing, Remote control: Stop
  - 2) It is possible to pump-down again.
  - 3) Electronic expansion valve (cooling/heating) is left fully open.

Note (1) After the stop of compressor, close the service valve at the gas side.

Caution: Since pressing the pump-down switch cancels communications with the indoor unit, the indoor unit and the remote control display “Transmission error – E5”. This is normal.

**(10) Base heater ON/OFF output control (Option)**

**(a) Base heater ON conditions**

When all of following conditions are satisfied, the base heater is turned ON.

- Outdoor air temperature (detected with Tho-A) is 3°C or lower.
- In the heating mode
- When the compressor is turned ON

**(b) Base heater OFF conditions**

When either one of following conditions is satisfied, the base heater is turned OFF.

- Outdoor air temperature (detected with Tho-A) is 5°C or higher.
- When the compressor stop has been detected for 30 minutes continuously
- In the cooling or dehumidifying mode

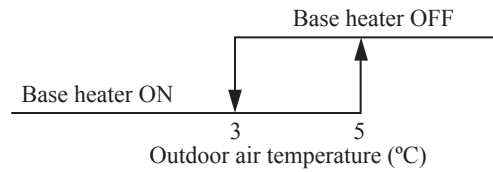



# 1.2 MAINTENANCE DATA

## 1.2.1 Diagnosing of microcomputer circuit

### (1) Selfdiagnosis function

#### (a) Check indicator table

Whether a failure exists or not on the indoor unit and outdoor unit can be know by the contents of remote control error code, indoor/outdoor unit green LED (power pilot lamp and microcomputer normality pilot lamp) or red LED (check pilot lamp).

#### (i) Indoor unit

Remote control		Indoor unit control PCB		Outdoor unit control PCB		Location of trouble	Description of trouble	Repair method	Reference page
Error code	Red LED	Red LED	Green LED (1)	Red LED	Green LED (1)				
No-indication	Stays OFF	Stays OFF	Keeps flashing	Stays OFF	Keeps flashing	—	• Normal operation	—	—
		Stays OFF	Stays OFF	2-time flash	Stays OFF	Indoor unit power source	• Power OFF, broken wire/blown fuse, broken transformer wire	Repair	100
		* 3-time flash	Keeps flashing	Stays OFF	Keeps flashing	Remote control wires	• Poor connection, breakage of remote control wire * For wire breaking at power ON, the LED is OFF.	Repair	101
				Remote control	• Defective remote control PCB	Replacement of remote control			
WAIT or INSPECT I/U		Stays OFF	Keeps flashing	2-time flash	Keeps flashing	Indoor-outdoor units connection wire	• Poor connection, breakage of indoor-outdoor units connection wire	Repair	102-111
						Remote control	• Improper setting of master and slave by remote control		
E1		Stays OFF	* Keeps flashing	Stays OFF	Keeps flashing	Remote control wires (Noise)	• Poor connection of remote control signal wire (White) * For wire breaking at power ON, the LED is OFF	Repair	113
						Remote control indoor unit control PCB	• Intrusion of noise in remote control wire * Defective remote control or indoor unit control PCB (defective communication circuit)?	Replacement of remote control or PCB	
E5		2-time flash	Keeps flashing	2-time flash	Keeps flashing	Indoor-outdoor units connection wire	• Poor connection of wire between indoor-outdoor units during operation (disconnection, loose connection) • Anomalous communication between indoor-outdoor units by noise, etc.	Repair	114
		2-time flash	Keeps flashing	Stays OFF	Keeps flashing	(Noise)	• CPU-runaway on outdoor unit control PCB	Power reset or Repair	
		2-time flash	Keeps flashing	Stays OFF	Keeps flashing	Outdoor unit control PCB	* Occurrence of defective outdoor unit control PCB on the way of power source (defective communication circuit)?	Replacement of PCB	
E6		1-time flash	Keeps flashing	Stays OFF	Keeps flashing	Indoor heat exchanger temperature sensor	• Defective indoor heat exchanger temperature sensor (defective element, broken wire, short-circuit) • Poor contact of temperature sensor connector	Replacement, repair of temperature sensor	115
						Indoor unit control PCB	* Defective indoor unit control PCB (Defective temperature sensor input circuit)?	Replacement of PCB	
E7		1-time flash	Keeps flashing	Stays OFF	Keeps flashing	Indoor return air temperature sensor	• Defective indoor return air temperature sensor (defective element, broken wire, short-circuit) • Poor contact of temperature sensor connector	Replacement, repair of temperature sensor	116
						Indoor unit control PCB	* Defective indoor unit control PCB (Defective temperature sensor input circuit)?	Replacement of PCB	
E8	Keeps flashing	1-time flash	Keeps flashing	Stays OFF	Keeps flashing	Installation or operating condition	• Heating over-load (Anomalously high indoor heat exchanger temperature)	Repair	117
						Indoor heat exchanger temperature sensor	• Defective indoor heat exchanger temperature sensor (short-circuit)	Replacement of temperature sensor	
						Indoor unit control PCB	* Defective indoor unit control PCB (Defective temperature sensor input circuit)?	Replacement of PCB	
E9		1-time flash	Keeps flashing	Stays OFF	Keeps flashing	Drain trouble	• Defective drain pump (DM), broken drain pump wire, disconnected connector	Replacement, repair of DM	118
						Float switch	• Anomalous float switch operation (malfunction)	Repair	
						Indoor unit control PCB	* Defective indoor unit control PCB (Defective float switch input circuit) * Defective indoor unit control PCB (Defective DM drive output circuit)?	Replacement of PCB	
						Option	• Defective option parts (At optional anomalous input setting)	Repair	
E10		Stays OFF	Keeps flashing	Stays OFF	Keeps flashing	Number of connected indoor units	• When multi-unit control by remote control is performed, the number of units is over	Repair	119
E11		Keeps flashing	Keeps flashing	Stays OFF	Keeps flashing	Address setting error	• Address setting error of indoor units	Repair	120
E14		3-time flash	Keeps flashing	Stays OFF	Keeps flashing	Indoor unit No. setting	• No master is assigned to slaves.	Repair	121
						Remote control wires	• Anomalous remote control wire connection, broken wire between master and slave units		
E16		1(2)-time flash	Keeps flashing	Stays OFF	Keeps flashing	Indoor fan motor	• Defective indoor fan motor	Replacement, repair	122
						Indoor unit power PCB	• Defective indoor unit power PCB	Replacement	
E18		1-time flash	Keeps flashing	Stays OFF	Keeps flashing	Address setting error	• Address setting error of master and slave indoor units	Repair	123
E19		1-time flash	Keeps flashing	Stays OFF	Keeps flashing	Indoor unit control PCB	• Indoor unit operation check error	Repair	124
E20		1(2)-time flash	Keeps flashing	Stays OFF	Keeps flashing	Indoor fan motor	• Indoor motor rotation speed anomaly	Replacement, repair	125
						Indoor unit power PCB	• Defective indoor unit power PCB	Replacement	
E21		1-time flash	Keeps flashing	Stays OFF	Keeps flashing	Panel switch detection	• Defective panel switch operation	Repair	126
E28		Stays OFF	Keeps flashing	Stays OFF	Keeps flashing	Remote control temperature sensor	• Broken wire of remote control temperature sensor	Repair	127

Notes (1) Normal indicator lamp (Indoor, outdoor units: Green) extinguishes (or lights continuously) only when CPU is anomalous. It keeps flashing in any trouble other than anomalous CPU.

(2) \* mark in the description of trouble means that, in ordinary diagnosis, it cannot identify the cause definitely, and, if the trouble is repaired by replacing the part, it is judged consequently that the replaced part was defective.

(ii) Outdoor unit

1) FDC71-140VNX, 100-140VSX

FDC100-140VNA, 100-140VSA

Remote control		Indoor unit control PCB		Outdoor unit control PCB		Outdoor inverter PCB	Location of trouble	Description of trouble	Repair method	Reference page
Error code	Red LED	Red LED	Green LED (1)	Red LED	Green LED (1)	Yellow LED				
E35		Stays OFF	Keeps flashing	1-time flash	Keeps flashing		Installation or operating condition	• Higher outdoor heat exchanger temperature	Repair	128
							Outdoor heat exchanger temperature sensor	• Defective outdoor heat exchanger temperature sensor	Replacement of temperature sensor	
E36		Stays OFF	Keeps flashing	1-time flash	Keeps flashing		Outdoor unit control PCB	*• Defective outdoor unit control PCB (Defective temperature sensor input circuit)?	Replacement of PCB	130
							Installation or operating condition	• Higher discharge temperature	Repair	
E37		Stays OFF	Keeps flashing	1-time flash	Keeps flashing	Keeps flashing	Discharge pipe temperature sensor	• Defective discharge pipe temperature sensor	Replacement, repair of temperature sensor	131
							Outdoor unit control PCB	*• Defective outdoor unit control PCB (Defective temperature sensor input circuit)?	Replacement of PCB	
E38		Stays OFF	Keeps flashing	1-time flash	Keeps flashing	Keeps flashing	Outdoor heat exchanger temperature sensor	• Defective outdoor heat exchanger temperature sensor, broken wire or poor connector connection	Replacement, repair of temperature sensor	132
							Outdoor unit control PCB	*• Defective outdoor unit control PCB (Defective temperature sensor input circuit)?	Replacement of PCB	
E39		Stays OFF	Keeps flashing	1-time flash	Keeps flashing	Keeps flashing	Outdoor air temperature sensor	• Defective outdoor air temperature sensor, broken wire or poor connector connection	Replacement, repair of temperature sensor	133
							Outdoor unit control PCB	*• Defective outdoor unit control PCB (Defective temperature sensor input circuit)?	Replacement of PCB	
E40		Stays OFF	Keeps flashing	1-time flash	Keeps flashing	Keeps flashing	Discharge pipe temperature sensor	• Defective discharge pipe temperature sensor, broken wire or poor connector connection	Replacement, repair of temperature sensor	134
							Outdoor unit control PCB	*• Defective outdoor unit control PCB (Defective temperature sensor input circuit)?	Replacement of PCB	
E41		Stays OFF	Keeps flashing	1-time flash	Keeps flashing	6-time flash	Installation or operating condition	• Rising high pressure (Operation of 63H1) • Service valve closing operation	Repair	136
							Outdoor unit control PCB	*• Defective outdoor unit control PCB (Defective 63H input circuit)?	Replacement of PCB	
E42		Stays OFF	Keeps flashing	1-time flash	Keeps flashing	1-time flash	Inverter PCB or radiator fin	• Power transistor overheat	Replacement of PCB or Repair	138•139
							Outdoor unit control PCB compressor	• Current cut (Anomalous compressor over-current)	Replacement of PCB	
E45		Stays OFF	Keeps flashing	1-time flash	Keeps flashing	Keeps flashing	Installation or operating condition	• Service valve closing operation	Repair	140
							Outdoor unit control PCB	• Anomalous outdoor unit control PCB communication	Replacement of PCB	
E47		Stays OFF	Keeps flashing	1-time flash	Keeps flashing	7-time flash	Inverter PCB	• Anomalous inverter PCB communication	Replacement of PCB	141
							Inverter PCB active filter	• Defective inverter PCB (Model FDC 71 only) Defective active filter of control.	Replacement	
E48		Stays OFF	Keeps flashing	1-time flash	Keeps flashing	Keeps flashing	Outdoor unit control PCB active filter	• Defective outdoor unit control PCB (Models FDC100-140VNA only) Defective active filter of control.	Replacement of PCB	142
							Outdoor fan motor	• Anomalous outdoor fan motor	Replacement, repair	
E49		Stays OFF	Keeps flashing	1-time flash	Keeps flashing	Keeps flashing	Outdoor unit control PCB	*• Defective outdoor unit control PCB (Defective motor input circuit)?	Replacement of PCB	144•145
							Installation or operating condition	• Low pressure error • Service valve closing operation	Repair	
E51		Stays OFF	Keeps flashing	1-time flash	Keeps flashing	Keeps flashing	Low pressure sensor	• Anomalous low pressure, broken wire of low pressure sensor or poor connector connection	Replacement, repair of sensor	147•148
							Outdoor unit control PCB	*• Defective outdoor unit control PCB (Defective sensor input circuit)?	Replacement of control PCB	
E53		Stays OFF	Keeps flashing	1-time flash	Keeps flashing	Keeps flashing	Inverter PCB	• Anomalous inverter PCB	Replacement of PCB	149
							Suction pipe temperature sensor	• Defective suction pipe temperature sensor, broken wire or poor connector connection	Replacement, repair of temperature sensor	
E54		Stays OFF	Keeps flashing	1-time flash	Keeps flashing	Keeps flashing	Outdoor unit control PCB	*• Defective outdoor unit PCB (Defective sensor input circuit)?	Replacement of control PCB	152
							Low pressure sensor	• Defective low pressure sensor	Replacement of sensor	
E57		Stays OFF	Keeps flashing	1-time flash	Keeps flashing	Keeps flashing	Outdoor unit control PCB	• Defective outdoor unit control PCB (Defective sensor input circuit)?	Replacement of control PCB	153
							Operation status	• Shortage in refrigerant quantity	Repair	
E58		Stays OFF	Keeps flashing	1-time flash	Keeps flashing	Keeps flashing	Installation status	• Service valve closing operation	Service valve opening check	155
							Compressor PCB	• Anomalous compressor by loss of synchronism (FDC100-140VNA / VSA only)	Replacement	
E59		Stays OFF	Keeps flashing	5 time flash	Keeps flashing	Stays OFF	Compressor inverter PCB	• Anomalous compressor startup	Replacement	157-1 158-161

Note (1) \* mark in the description of trouble means that, in ordinary diagnosis, it cannot identify the cause definitely, and, if the trouble is repaired by replacing the part, it is judged consequently that the replaced part was defective.

2) FDC200, 250VSA

Remote control		Indoor unit control PCB		Outdoor unit control PCB		Outdoor inverter PCB	Location of trouble	Description of trouble	Repair method	Reference page
Error code	Red LED	Red LED	Green LED (1)	Red LED	Green LED (1)	Yellow LED				
E35		Stays OFF	Keeps flashing	1-time flash	Keeps flashing	Keeps flashing	Installation or operating condition	• Higher outdoor heat exchanger temperature	Repair	128
							Outdoor heat exchanger temperature sensor	• Defective outdoor heat exchanger temperature sensor	Replacement of temperature sensor	
							Outdoor unit control PCB	*• Defective outdoor unit control PCB (Defective temperature sensor input circuit)?	Replacement of PCB	
E36		Stays OFF	Keeps flashing	1-time flash	Keeps flashing	Keeps flashing	Installation or operating condition	• Higher discharge temperature	Repair	130
							Discharge pipe temperature sensor	• Defective discharge pipe temperature sensor	Replacement, repair of temperature sensor	
							Outdoor unit control PCB	*• Defective outdoor unit control PCB (Defective temperature sensor input circuit)?	Replacement of PCB	
E37		Stays OFF	Keeps flashing	1-time flash	Keeps flashing	Keeps flashing	Outdoor heat exchanger temperature sensor	• Defective outdoor heat exchanger temperature sensor, broken wire or poor connector connection	Replacement, repair of temperature sensor	131
							Outdoor unit control PCB	*• Defective outdoor unit control PCB (Defective temperature sensor input circuit)?	Replacement of PCB	
E38		Stays OFF	Keeps flashing	1-time flash	Keeps flashing	Keeps flashing	Outdoor air temperature sensor	• Defective outdoor air temperature sensor, broken wire or poor connector	Replacement, repair of temperature sensor	132
							Outdoor unit control PCB	*• Defective outdoor unit control PCB (Defective temperature sensor input circuit)?	Replacement of PCB	
E39		Stays OFF	Keeps flashing	1-time flash	Keeps flashing	Keeps flashing	Discharge pipe temperature sensor	• Defective discharge pipe temperature sensor, broken wire or poor connector connection	Replacement, repair of temperature sensor	133
							Outdoor unit control PCB	*• Defective outdoor unit control PCB (Defective temperature sensor input circuit)?	Replacement of PCB	
E40		Stays OFF	Keeps flashing	1-time flash	Keeps flashing	Keeps flashing	Installation or operating condition	• Rising high pressure (Operation of 63H1) • Service valve closing operation	Repair	134
							Outdoor unit control PCB	*• Defective outdoor unit control PCB (Defective 63H input circuit)?	Replacement of PCB	
E41		Stays OFF	Keeps flashing	1-time flash	Keeps flashing	2-time or 8-time flash	Inverter PCB or radiator fin	• Power transistor overheat	Replacement of PCB or Repair	137
E42		Stays OFF	Keeps flashing	1-time flash	Keeps flashing	1-time or 9-time flash	Outdoor unit control PCB compressor	• Current cut (Anomalous compressor over-current)	Replacement of PCB	138 · 139
							Installation or operating condition	• Service valve closing operation	Repair	
E45		Stays OFF	Keeps flashing	1-time flash	Keeps flashing	Keeps flashing	Outdoor unit control PCB	• Anomalous outdoor unit control PCB communication	Service valve opening check	140
							Inverter PCB	• Anomalous inverter PCB communication	Replacement of PCB	
E48		Stays OFF	Keeps flashing	1-time flash	Keeps flashing	Keeps flashing	Outdoor fan motor	• Anomalous outdoor fan motor	Replacement, repair	144
							Outdoor unit control PCB	*• Defective outdoor unit control PCB (Defective motor input circuit)?	Replacement of PCB	
E49		Stays OFF	Keeps flashing	1-time flash	Keeps flashing	Keeps flashing	Installation or operating condition	• Low pressure error • Service valve closing operation	Repair	147 · 148
							Low pressure sensor	• Anomalous low pressure, broken wire of low pressure sensor or poor connector connection	Replacement, repair of sensor	
							Outdoor unit control PCB	*• Defective outdoor unit control PCB (Defective sensor input circuit)?	Replacement of control PCB	
E51		Stays OFF	Keeps flashing	1-time flash	Keeps flashing	2-time or 8-time flash	Inverter PCB	• Anomalous inverter PCB	Replacement of PCB	150
E53		Stays OFF	Keeps flashing	1-time flash	Keeps flashing	Keeps flashing	Suction pipe temperature sensor	• Defective suction pipe temperature sensor, broken wire or poor connector connection	Replacement, repair of temperature sensor	152
							Outdoor unit control PCB	*• Defective outdoor unit PCB (Defective sensor input circuit)?	Replacement of control PCB	
E54		Stays OFF	Keeps flashing	1-time flash	Keeps flashing	Keeps flashing	Low pressure sensor	• Defective low pressure sensor	Replacement of sensor	153
							Outdoor unit control PCB	• Defective outdoor unit control PCB (Defective sensor input circuit)?	Replacement of control PCB	
E55		Stays OFF	Keeps flashing	1-time flash	Keeps flashing	Keeps flashing	Compressor under dome temperature sensor	• Defective compressor under dome temperature sensor (Model FDC250 only)	Replacement of temperature sensor	154
							Outdoor unit control PCB	• Defective outdoor unit control PCB (Defective sensor input circuit)? (Model FDC250 only)	Replacement of control PCB	
E57		Stays OFF	Keeps flashing	1-time flash	Keeps flashing	Keeps flashing	Operation status	• Shortage in refrigerant quantity	Repair	155
							Installation status	• Service valve closing operation	Service valve opening check	
E59		Stays OFF	Keeps flashing	5-time flash	Keeps flashing	4-time flash	Compressor inverter PCB	• Anomalous compressor startup	Replacement	162 · 163

Note (1) \* mark in the description of trouble means that, in ordinary diagnosis, it cannot identify the cause definitely, and, if the trouble is repaired by replacing the part, it is judged consequently that the replaced part was defective.

(iii) Option control in-use

Error code	Indoor unit control PCB			Outdoor unit control PCB		Description of trouble	Repair method
	Red LED	Red LED	Green LED	Red LED	Green LED		
E75	Keeps flashing	Stays OFF	Keeps flashing	Stays OFF	Keeps flashing	• Communication error (Defective communication circuit on the main unit of SC-SL2NA-E or SC-SL4-AE/BE) etc.	Replacement

## 3) FDC71-100VNP

Remote control		Indoor unit control PCB		Outdoor unit control PCB	Location of trouble	Description of trouble	Repair method	Reference page
Error code	Red LED	Red LED	Green LED	Red LED (2)				
E35		Stays OFF	Keeps flashing	2-time flash	Installation, operation status	• Higher outdoor heat exchanger temperature	Repair	129
					Outdoor heat exchanger temperature sensor	• Defective outdoor heat exchanger temperature sensor	Replacement, repair of temperature sensor	
					Outdoor unit control PCB	* Defective outdoor unit control PCB (Defective temperature sensor input circuit)?	Replacement of PCB	
E36		Stays OFF	Keeps flashing	5-time flash	Installation, operation status	• Higher discharge temperature	Repair	130
					Discharge pipe temperature sensor	• Defective discharge pipe temperature sensor	Replacement, repair of temperature sensor	
					Outdoor unit control PCB	* Defective outdoor unit control PCB (Defective temperature sensor input circuit)?	Replacement of PCB	
E37		Stays OFF	Keeps flashing	8-time flash	Outdoor heat exchanger temperature sensor	• Defective outdoor heat exchanger temperature sensor, broken wire or poor connector connection	Replacement, repair of temperature sensor	131
					Outdoor unit control PCB	* Defective outdoor unit control PCB (Defective temperature sensor input circuit)?	Replacement of PCB	
E38		Stays OFF	Keeps flashing	8-time flash	Outdoor air temperature sensor	• Defective outdoor air temperature sensor, broken wire or poor connector connection	Replacement, repair of temperature sensor	132
					Outdoor unit control PCB	* Defective outdoor unit control PCB (Defective temperature sensor input circuit)?	Replacement of PCB	
E39	Keeps flashing	Stays OFF	Keeps flashing	8-time flash	Discharge pipe temperature sensor	• Defective discharge pipe temperature sensor, broken wire or poor connector connection	Replacement, repair of temperature sensor	133
					Outdoor unit control PCB	* Defective outdoor unit control PCB (Defective temperature sensor input circuit)?	Replacement of PCB	
E40		Stays OFF	Keeps flashing	4-time flash	Installation, operation status	• Service valve (gas side) closing operation	Replacement	135
E42		Stays OFF	Keeps flashing	1-time flash	Outdoor unit control PCB, compressor	• Current cut (Anomalous compressor over-current)	Replacement of PCB	138•139
					Installation, operation status	• Service valve closing operation	Repair	
E47		Stays OFF	Keeps flashing	2-time flash	Outdoor unit control PCB	• Defective active filter	Repair PCB replacement	143
E48		Stays OFF	Keeps flashing	ON	Outdoor fan motor	• Defective outdoor fan motor	Replacement	146
					Outdoor unit control PCB	• Defective outdoor unit control PCB		
E51		Stays OFF	Keeps flashing	1-time flash	Power transistor error (Outdoor unit control PCB)	• Power transistor error	Replacement of PCB	151
E57		Stays OFF	Keeps flashing	2-time flash	Operation status	• Shortage in refrigerant quantity	Repair	156
					Installation status	• Service valve closing operation	Service valve opening check	
E58		Stays OFF	Keeps flashing	3-time flash	• Overload operation • Overcharge • Compressor locking	• Current safe stop	Replacement	157
E59		Stays OFF	Keeps flashing	2-time flash	Compressor, outdoor unit control PCB	• Anomalous compressor startup	Replacement	164
E60		Stays OFF	Keeps flashing	7-time flash	Compressor	• Anomalous compressor rotor lock	Replacement	165
WAIT or INSPECT I/U		Stays OFF	Keeps flashing	6-time flash	Indoor-outdoor connection wire	• Poor connection, breakage of indoor-outdoor unit connection wire	Repair	—

Notes (1) \* mark in the description of trouble means that, in ordinary diagnosis, it cannot identify the cause definitely, and, if the trouble is repaired by replacing the part, it is judged consequently that the replaced part was defective.

(2) This LED is installed on model FDC71VNP.

(iv) Display sequence of error codes or inspection indicator lamps

■ Occurrence of one kind of error



Displays are shown respectively according to errors.

■ Occurrence of plural kinds of error

Section	Category of display
Error code on remote control	<ul style="list-style-type: none"> <li>• Displays the error of higher priority (When plural errors are persisting)</li> </ul>
Red LED on indoor unit control PCB	
Red LED on outdoor unit control PCB (1)	

*E 1 > E 5 > ..... > E 10 > E 32 > ..... > E 60*

■ Error detecting timing

Section	Error description	Error code	Error detecting timing
Indoor	Drain trouble (Float switch activated)	<i>E 9</i>	Whenever float switch is activated after 30 seconds had past since power ON.
	Communication error at initial operation	“  WAIT  ”	No communication between indoor and outdoor units is established at initial operation.
	Remote control communication circuit error	<i>E 1</i>	Communication between indoor unit and remote control is interrupted for more than 2 minutes continuously after initial communication was established.
	Communication error during operation	<i>E 5</i>	Communication between indoor and outdoor units is interrupted for more than 2 minutes continuously after initial communication was established.
	Excessive number of connected indoor units by controlling with one remote control	<i>E 10</i>	Whenever excessively connected indoor units is detected after power ON.
	Return air temperature sensor anomaly	<i>E 7</i>	-50°C or lower is detected for 5 seconds continuously within 60 minutes after initial detection of this anomalous temperature.
	Indoor heat exchanger temperature sensor anomaly	<i>E 6</i>	-50°C or lower is detected for 5 seconds continuously within 60 minutes after initial detection of this anomalous temperature. Or 70°C or higher is detected for 5 seconds continuously
Outdoor	Outdoor air temperature sensor anomaly	<i>E 38</i>	-45(-55)°C or lower is detected for 5 seconds continuously 3 times within 40 minutes after initial detection of this anomalous temperature. Or -45(-55)°C or lower is detected for 5 seconds continuously within 20 seconds after compressor ON.
	Outdoor heat exchanger temperature sensor anomaly	<i>E 37</i>	-50(-55)°C or lower is detected for 5 seconds continuously 3 times within 40 minutes after initial detection of this anomalous temperature. Or -50(-55)°C or lower is detected for 5 seconds continuously within 20 seconds after compressor ON.
	Discharge pipe temperature sensor anomaly	<i>E 39</i>	-10(-25)°C or lower is detected for 5 seconds continuously 3 times within 40 minutes after initial detection of this anomalous temperature.
	Suction pipe temperature sensor anomaly	<i>E 53</i>	-50°C or lower is detected for 5 seconds continuously 3 times within 40 minutes after initial detection of this anomalous temperature.
	Low pressure sensor anomaly	<i>E 54</i>	0V or lower or 4.0V or higher is detected for 5 seconds continuously 3 times within 40 minutes after initial detection of this anomalous pressure.
	Compressor under dome temperature sensor anomaly	<i>E 55</i>	-50°C or lower is detected for 5 seconds continuously 3 times within 40 minutes after initial detection of this anomalous temperature.

Notes (1) This LED isn't installed on models FDC71-100VNP.

(2) Value in ( ) are for the models FDC71-100VNP.

■ **Error log and reset**

Error indicator	Memorized error log	Reset
Remote control display	• Higher priority error is memorized.	• Stop the unit by pressing the ON/OFF switch of remote control. • If the unit has recovered from anomaly, it can be operated.
Red LED on indoor unit control PCB	• Not memorized.	
Red LED on outdoor unit control PCB	• Memorizes a mode of higher priority.	

■ **Resetting the error log**

- Resetting the memorized error log in the remote control  
Holding down “CHECK” button, press “TIMER” button to reset the error log memorized in the remote control.
- Resetting the memorized error log in the indoor unit  
The remote control transmits error log erase command to the indoor unit when “VENTI” button is pressed while holding down “CHECK” button.  
Receiving the command, the indoor unit erase the log and answer the status of no error.

(2) **Troubleshooting procedure**

When any trouble has occurred, inspect as follows. Details of respective inspection method will be described on later pages.

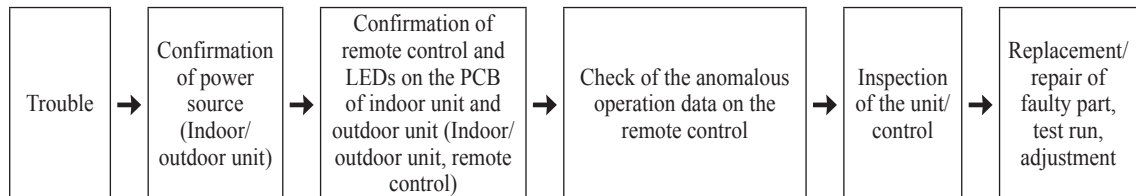

(3) **Troubleshooting at the indoor unit**

(a) **FDT series**

With the troubleshooting, find out any defective part by checking the voltage (AC, DC), resistance, etc. at respective connectors at around the indoor unit PCB, according to the inspection display or operation status of unit (the compressor does not run, fan does not run, the 4-way valve does not switch, etc.), and replace or repair in the unit of following part.

(i) **Replacement part related to indoor PCB's**

Control PCB, power source PCB, temperature sensor (return air, indoor heat exchanger), remote control switch, limit switch, transformer and fuse

Note (1) With regard to parts of high voltage circuits and refrigeration cycle, judge it according to ordinary inspection methods.

(ii) **Instruction of how to replace indoor unit control PCB**

**SAFETY PRECAUTIONS**

- Read the "SAFETY PRECAUTIONS" carefully first of all and then strictly follow it during the replacement in order to protect yourself.
- The precautionary items mentioned below are distinguished into two levels, WARNING and CAUTION. Both mentions the important items to protect your health and safety so strictly follow them by any means.

	<b>WARNING</b>
	<b>CAUTION</b>

Wrong installation might cause serious consequences depending on circumstances.

- After completing the replacement, do commissioning to confirm there are no anomaly.

**WARNING**

- Replacement should be performed by the specialist.  
If you replace the PCB by yourself, it may lead to serious trouble such as electric shock or fire.
- Replace the PCB correctly according to these instructions.  
Improper replacement may cause electric shock or fire.
- Shut off the power before electrical wiring work.  
Replacement during the applying the current would cause the electric shock, unit failure or improper running.  
It would cause the damage of connected equipment such as fan motor, etc.
- Fasten the wiring to the terminal securely, and hold the cable securely so as not to apply unexpected stress on the terminal.  
Loose connections or hold could result in abnormal heat generation or fire.
- Check the connection of wiring to PCB correctly before turning on the power, after replacement.  
Defectiveness of replacement may cause electric shock or fire.

**CAUTION**

- In connecting connector onto the PCB, connect not to deform the PCB. It may cause breakage or malfunction.
- Insert connector securely, and hook stopper. It may cause fire or improper running.
- Bundle the cables together so as not to be pinched or be tensioned. It may cause malfunction or electric shock for disconnection or deformation.

1) Model FDT series

- a) Replace the control PCB
  - i) Unscrew terminal (Arrow A) of the "E1" wiring (yellow/green) that is connected to PCB.
  - ii) Replace the PCB only after all the wirings connected to the connector are removed.
  - iii) Fix the board such that it will not pinch any of the wires.
  - iv) Switch setting must be same setting as that of the removed PCB.
  - v) Reconnect the all wirings to the PCB, that was removed in ii).
  - vi) Rescrew the terminal (Arrow A) of the "E1" wiring, that was removed in i).
  
- b) Control PCB (※Parts mounting are different by the kind of PCB.)

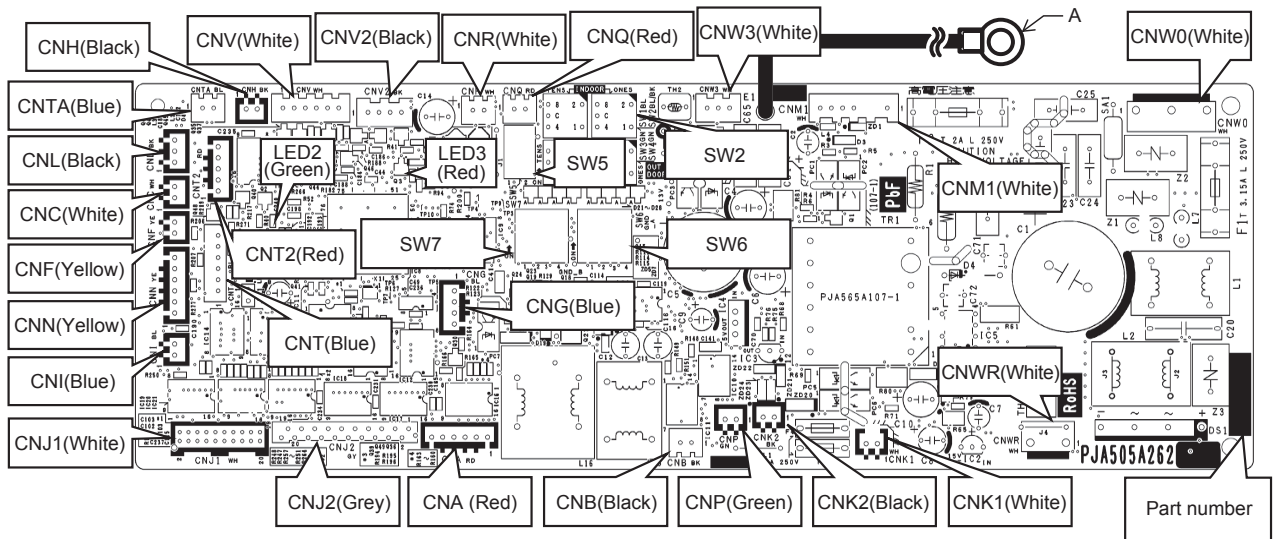

PSC012D050

● **DIP switch setting list**

Switch	Description		Default setting		Remark
SW2	Address No. setting at plural indoor units control by 1 R/C		0		0-F
SW5-1	Master/Slave setting	Master*/Slave	OFF		See table 2.
SW5-2			OFF		
SW6-1	Model selection		As per model		See table 1.
SW6-2					
SW6-3					
SW6-4					
SW7-1	Test run, drain motor	Normal*/Test run	OFF	Normal	
SW7-2	Reserved		OFF		Keep OFF
SW7-3	Reserved		OFF		Keep OFF
SW7-4	Reserved		OFF		Keep OFF
JSL1	Superlink terminal spare	Normal*/switch to spare	With		

\* Default setting

Table 1: Indoor unit model selection with SW6-1-SW6-4

Switch	71VH	100VH	125VH	140VH
SW6-1	ON	ON	OFF	ON
SW6-2	OFF	ON	OFF	OFF
SW6-3	OFF	OFF	ON	ON
SW6-4	ON	ON	ON	ON

Table 2: Indoor unit Master/Slave setting with SW5-1,SW5-2

Switch	SW5-1	SW5-2
Master	OFF	OFF
Slave1	OFF	ON
Slave2	ON	OFF
Slave3	ON	ON



**(4) Troubleshooting at the outdoor unit**

When troubleshooting the outdoor unit, firstly assess the overview of malfunction and try to presume the cause and the faulty part by checking the error code displayed on the remote control and flashing pattern of indicator lamps (Red LED and Green LED), and then proceed further inspection and remedy it.

Self-diagnosis system by microcomputer on indoor unit and outdoor unit PCB can assist to find the cause of malfunction smoothly by making a diagnosis of not only the anomaly of microcomputer, but also the anomaly in power source system, installation space, overload resulting from improper charging amount of refrigerant and etc.

Unless the power is reset, the error log is saved in memory and the inspection indicator lamps on outdoor unit PCB keep flashing after automatical recovering from malfunction.

After automatical recovering from malfunction, if any another error mode which has a higher priority than the previous error saved in memory occurs, it is overwritten in memory and is displayed.

**[Reset of power source]**

Be sure to avoid electrical shock, when replacing or checking the outdoor unit control PCB, because some voltage is still retained in the electrolytic capacitor on the PCB even after shutting down the power source to the outdoor unit.

Be sure to start repairing work, after confirming that the red LED or green LED on the PCB has been extinguished for more than 10 seconds after more than 3 minutes had been passed since power shut down, and reconfirming that voltage has been discharged sufficiently by measuring the voltage (DC) between both terminals of electrolytic capacitor (C58) (Measurement of voltage may be disturbed by the moisture-proof coating. In such case, remove the coating and measure it by taking care of avoiding electrical shock)

Note(1) The red LED or green LED isn't installed on models SRC40-60, FDC71-100VNP.

**(a) Module of part to be replaced for outdoor unit control**

Outdoor unit control PCB, Inverter PCB, Temperature sensor (of outdoor heat exchanger, discharge pipe, outdoor air, IPM, suction pipe and under dome), Fuses (for power source and control PCB), Noise filter, Capacitor and Reactor.

**(b) Replacement procedure of outdoor unit control PCB**

<b>Precautions for Safety</b>	
<ul style="list-style-type: none"> <li>• Since the following precaution is the important contents for safety, be sure to observe them. WARNING and CAUTION are described as follows:</li> </ul>	
<div style="border: 1px solid black; padding: 2px; display: inline-block;"> <b>WARNING</b></div>	Indicates an imminently hazardous situation which will result in death or serious injury if proper safety procedures and instructions are not adhered to.
<div style="border: 1px solid black; padding: 2px; display: inline-block;"> <b>CAUTION</b></div>	Indicates a potentially hazardous situation which may result in minor or moderate injury if proper safety procedures and instructions are not adhered to.
<b>WARNING</b>	
<ul style="list-style-type: none"> <li>• Securely replace the PCB according to this procedure. If the PCB is incorrectly replaced, it will cause an electric shock or fire.</li> <li>• Be sure to check that the power source for the outdoor unit is turned OFF before replacing the PCB. The PCB replacement under current-carrying will cause an electric shock or fire.</li> <li>• After finishing the PCB replacement, check that wiring is correctly connected with the PCB before power distribution. If the PCB is incorrectly replaced, it will cause an electric shock or fire.</li> </ul>	
<b>CAUTION</b>	
<ul style="list-style-type: none"> <li>• Band the wiring so as not to tense because it will cause an electric shock.</li> </ul>	

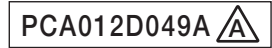

(i) Model FDC71VNX

- 1) Replace the PCB after elapsing 3 minutes from power OFF.  
(Be sure to measure voltage (DC) between T26 and T27 on inverter PCB, and check that the voltage is discharged sufficiently(10V or less).(Refer to Fig.2))
- 2) Disconnect the connectors from the control PCB.
- 3) Match the switches setting (SW4) with the former PCB.
- 4) Connect the connectors to the control PCB.(Confirm the connectors are not half inserted.)

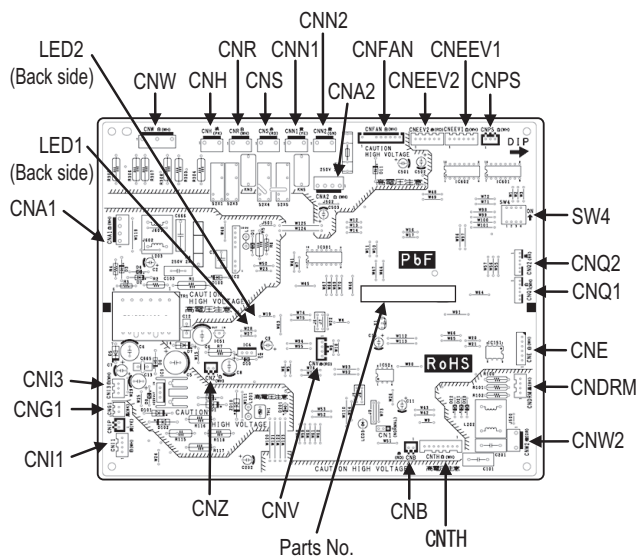

Fig.1 Parts arrangement view

After elapsing 3 minutes from power OFF

Voltage measurement point (T26 (red), T27 (blue))

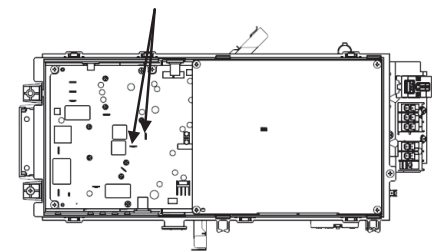

Fig.2 Position of terminal

\*Presence and shape of electric component may vary according to model.

Connectors are not half inserted

PCA012D043 

(ii) Models FDC100VNX, 125VNX, 140VNX  
FDC100VSX, 125VSX, 140VSX

- 1) Replace the PCB **after elapsing 3 minutes from power OFF.**  
**(Be sure to measure voltage (DC)** on both capacitor terminals located in control back, and **check that the voltage is discharged sufficiently.)**
- 2) Disconnect the connectors from the control PCB.
- 3) Disconnect the white wiring passing through CT1 on the PCB before replacing the PCB.
- 4) Match the setting switches (SW3-5, JSW) with the former PCB.
- 5) Tighten up a screw after passing white wiring through CT1 of the changed.
- 6) Connect the connectors with the control PCB referring to the parts arrangement of Fig. 1.  
**(Confirm the connectors are not half inserted.)**

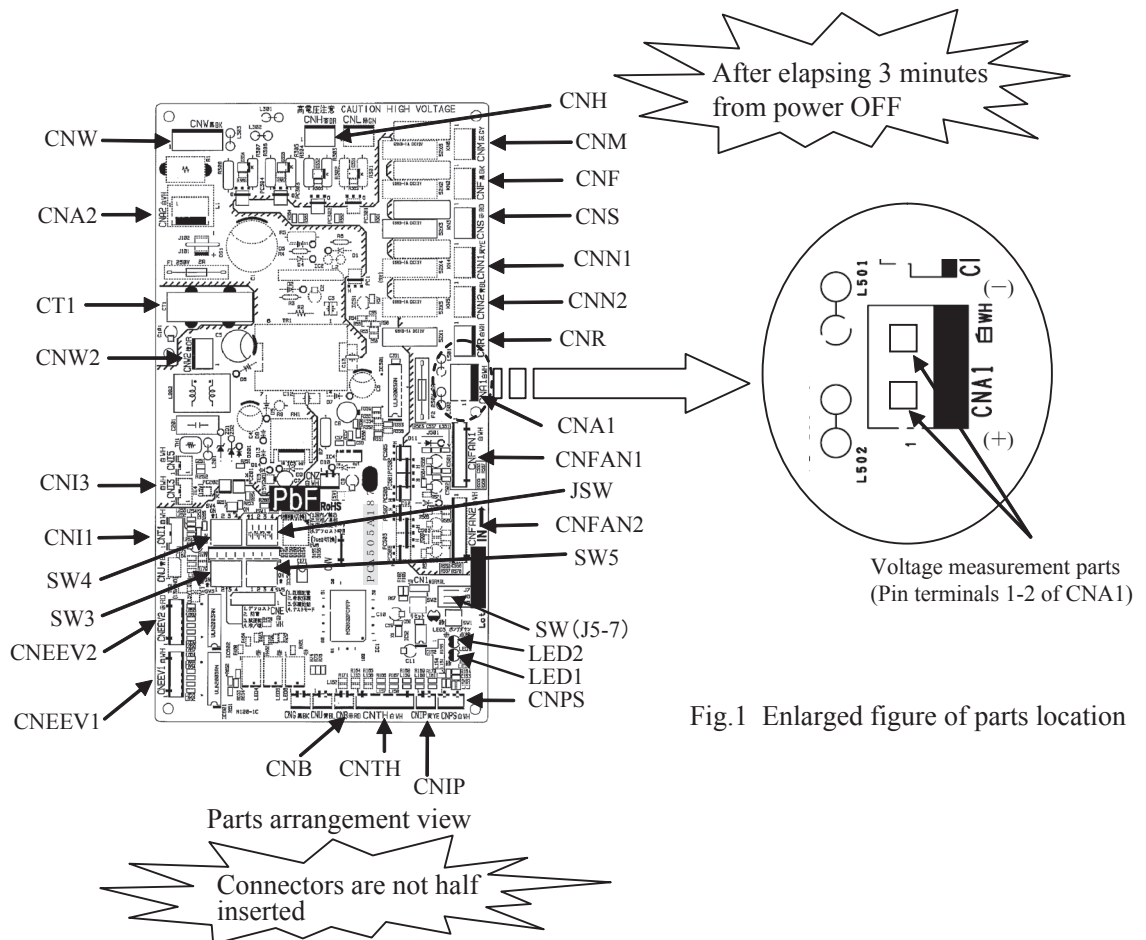

Fig.1 Enlarged figure of parts location

**(iii) Models FDC100VNA, 125VNA, 140VNA****1) Disassembly**

- a) After the breaker is shut down, remove the service panel, top panel and rear panel. (Refer to Fig.1).
- b) Don't touch the main PCB until three minutes have passed after the breaker is shut down.  
(After having shut down the breaker, some capacitor is held by high voltage. It is very dangerous to touch the main PCB in this condition.)

In the situation that harnesses are connected to main PCB, **be sure to measure voltage (DC)** on main PCB, and **check that the voltage is discharged sufficiently (DC voltage 30 V or less)**. (Refer to Fig.2)

- c) Disconnect the connectors, faston terminals and round terminals from the main PCB as shown in Fig.2.  
And then remove the fixing screws (3 places) as shown in Fig.3.

After removing the main PCB, wipe off the heat conduction sheet neatly from the copper plate.

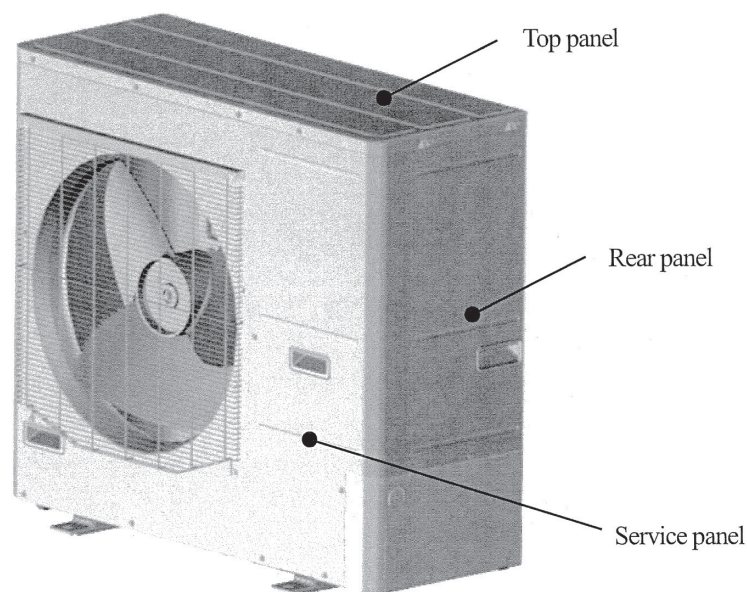

Fig.1 Outdoor unit overall view

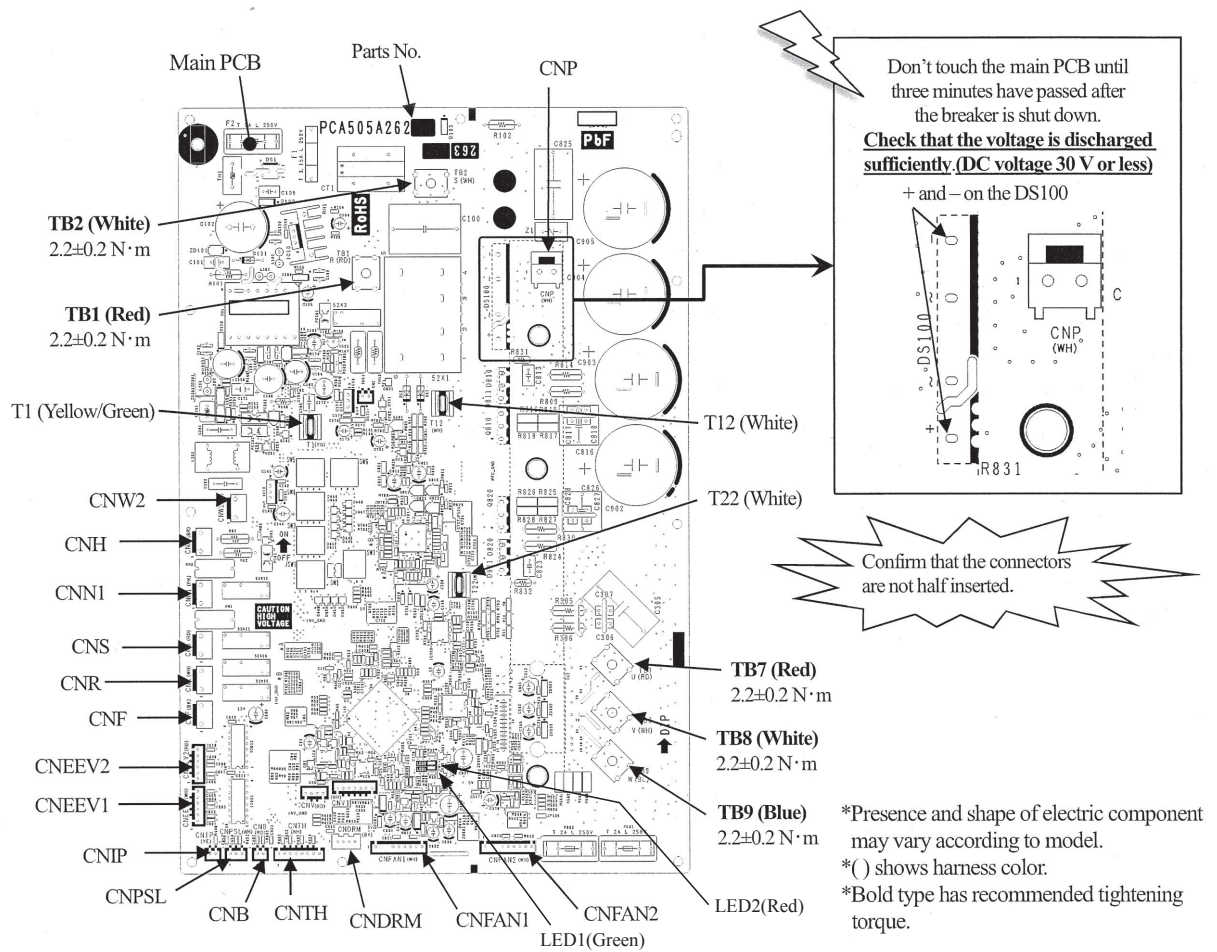

Fig.2 Parts arrangement view of main PCB and voltage measurement points

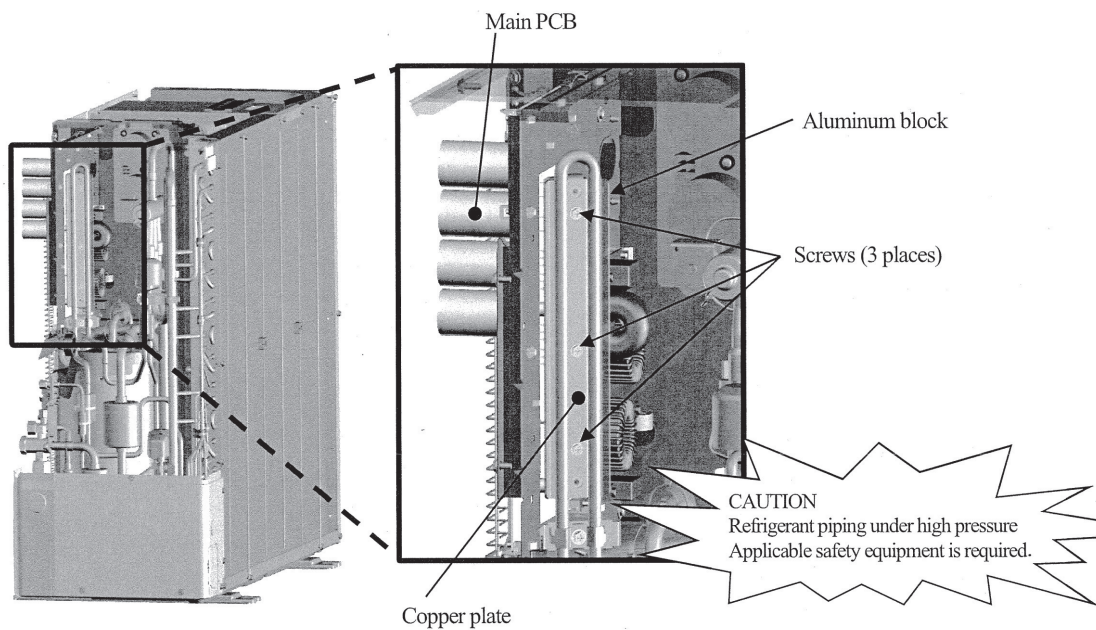

Fig.3 Outdoor unit side view

**2) Exchange**

- a) Match the setting of new main PCB switches (JSW1, SW3-7) with former main PCB. (Refer to Fig.4)
- b) Turn over the separator of new heat conduction sheet and paste the heat conduction sheet on the aluminum block. (Refer to Fig.5)
- c) Install the attached harness clip on the new main PCB as shown in Fig.6.

**3) Installation**

- a) Install the new main PCB on the control and tighten the screw as shown in Fig.7.
- b) Reconnect the connectors, faston terminals and round terminals to the main PCB as before. (Refer to Fig.2)  
(Confirm that the **connectors are not half inserted.**)

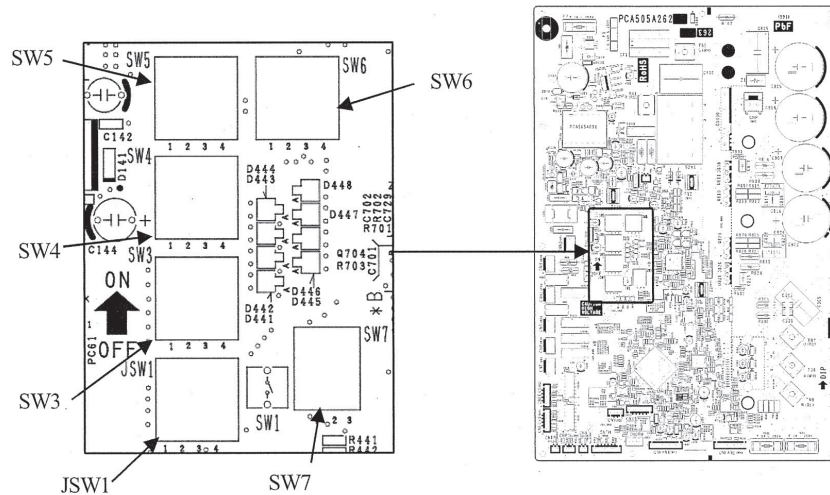

Fig.4 Switch position of main PCB

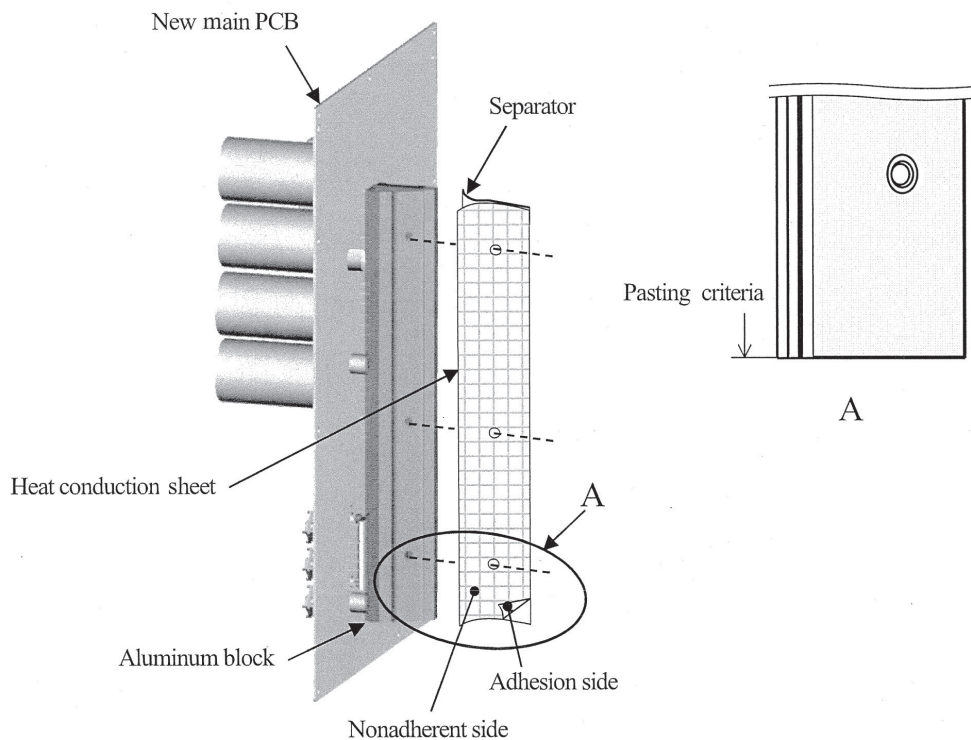

Fig.5 Detail of paste for the heat conduction sheet

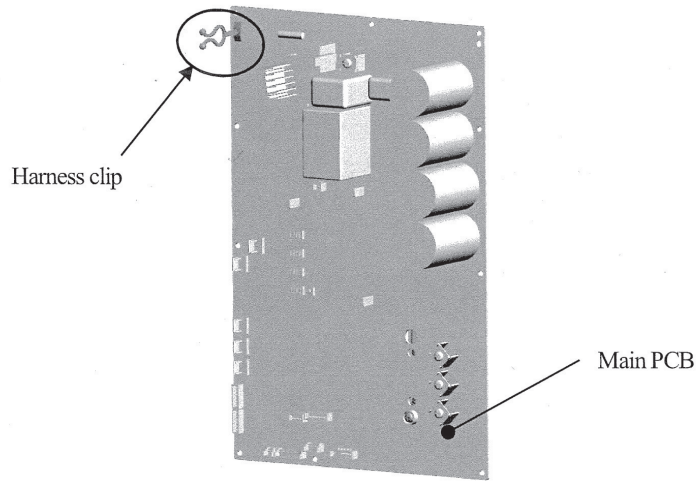

Fig.6 Install of the harness clip

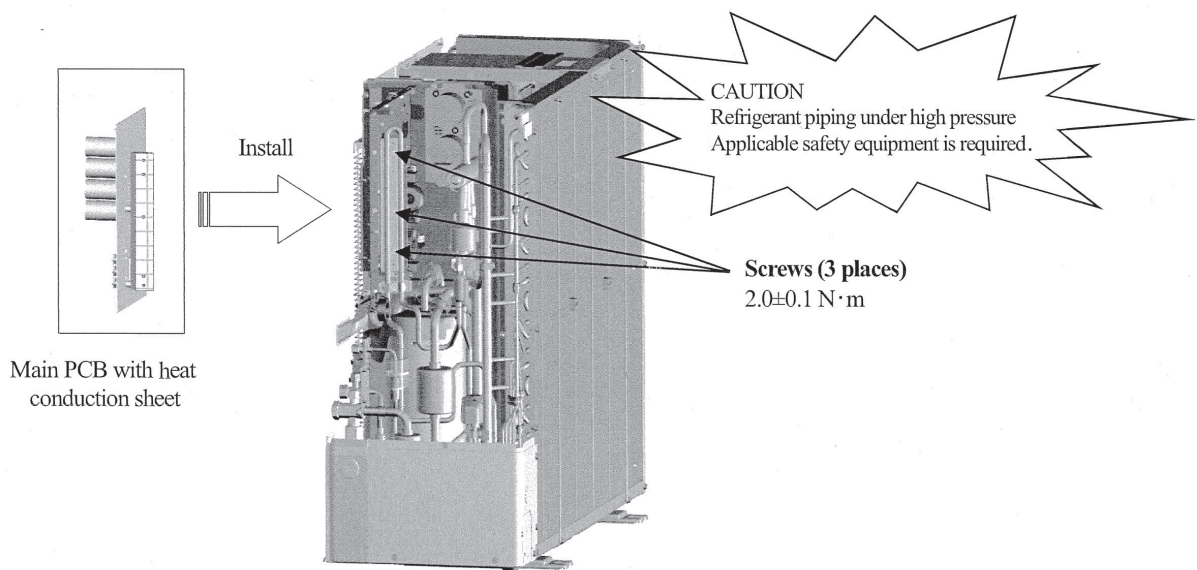
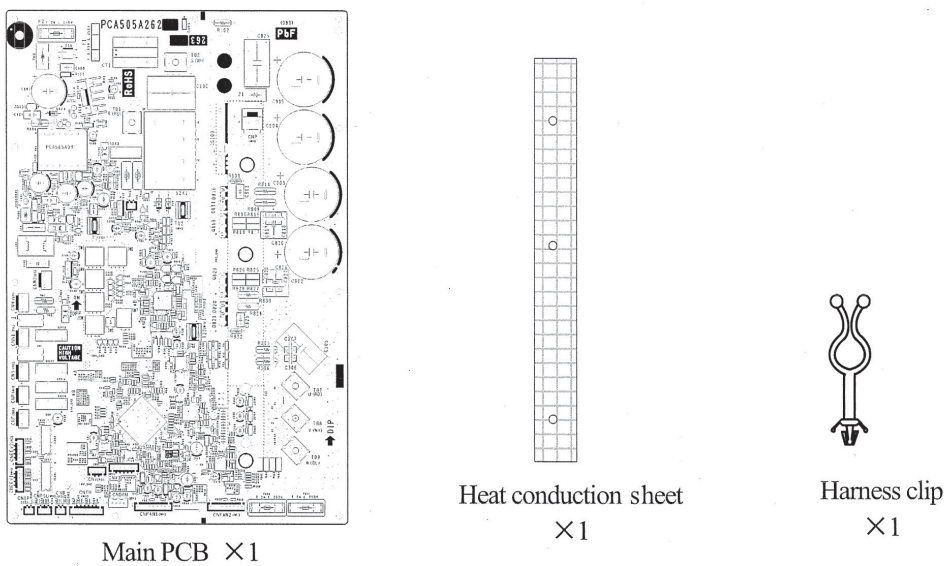

Fig.7 Install of the main PCB

● Accessories

Check the following accessories are packed in. (Except this manual)



**(iv) Models FDC100VSA, 125VSA, 140VSA****1) Disassembly**

- a) After the breaker is shut down, remove the service panel, top panel and rear panel. (Refer to Fig.1).
- b) Don't touch the main PCB until three minutes have passed after the breaker is shut down.  
(After having shut down the breaker, some capacitor is held by high voltage. It is very dangerous to touch the main PCB in this condition.)  
In the situation that harnesses are connected to main PCB, **be sure to measure voltage (DC)** on main PCB, and **check that the voltage is discharged sufficiently (DC voltage 30 V or less)**. (Refer to Fig.2)
- c) Disconnect the connectors, faston terminals and round terminals from the main PCB as shown in Fig.2.  
And then remove the fixing screws (3 places) as shown in Fig.3.  
After removing the main PCB, wipe off the heat conduction sheet neatly from the copper plate.

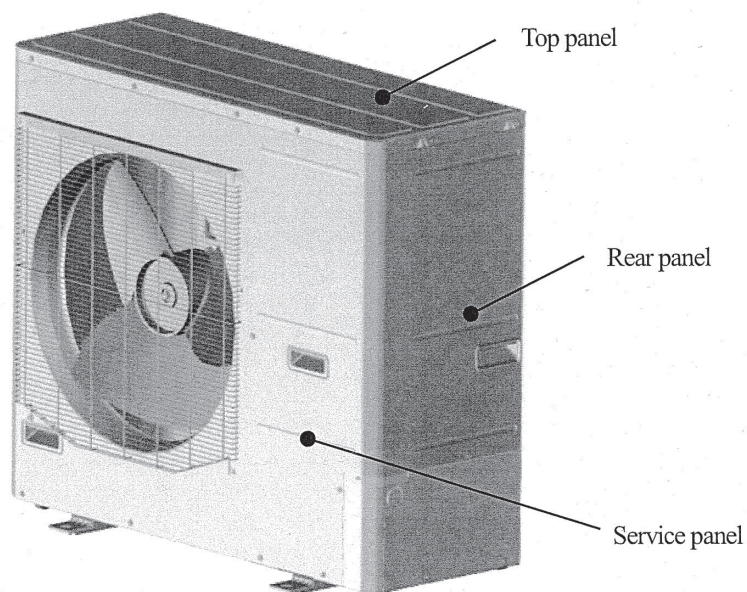

Fig.1 Outdoor unit overall view



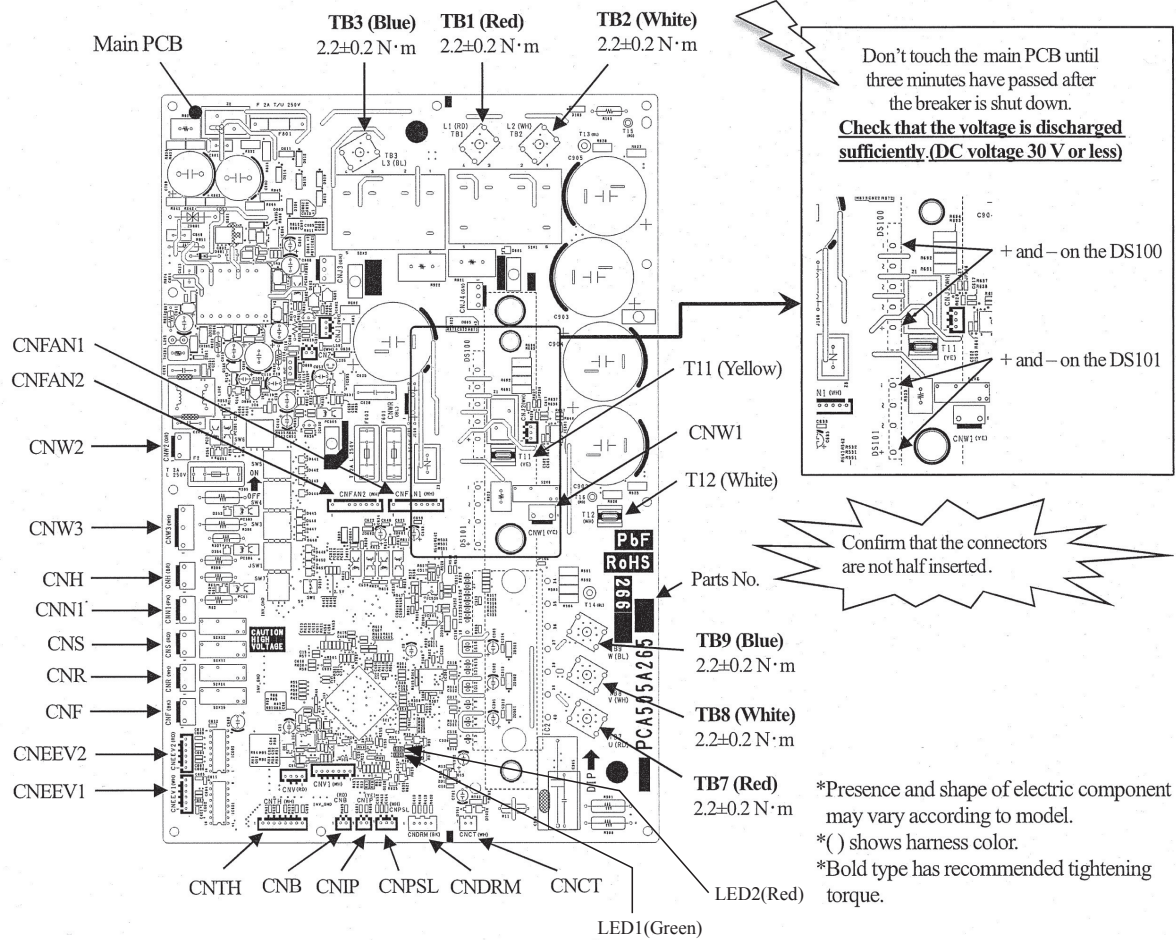

Fig.2 Parts arrangement view of main PCB and voltage measurement points

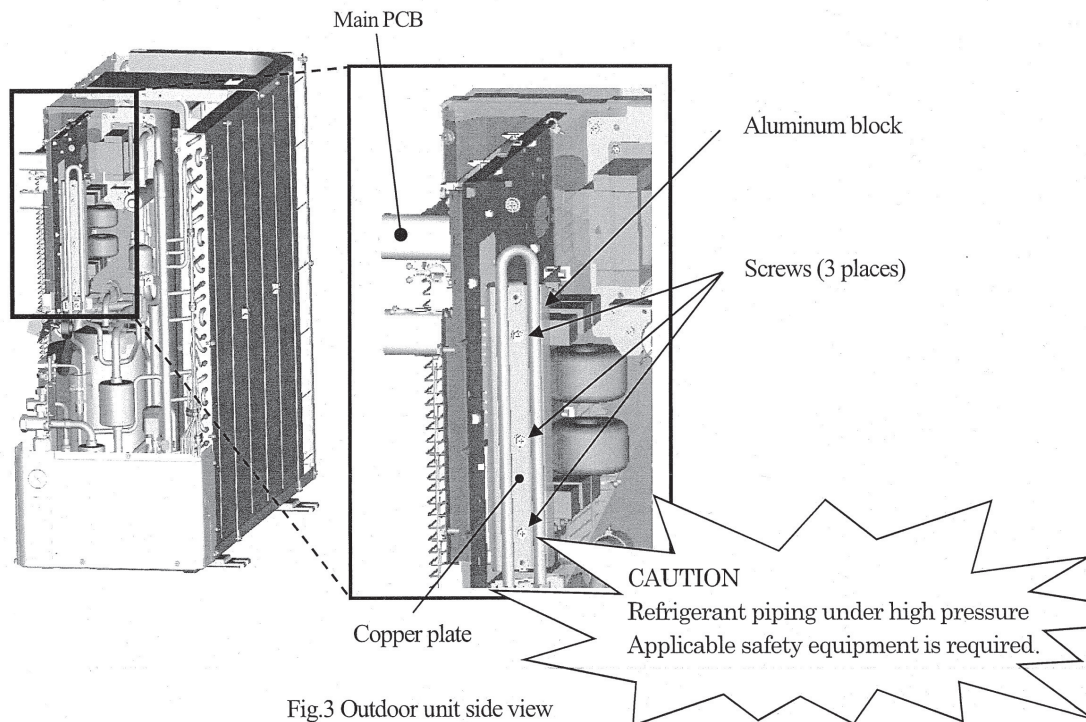

Fig.3 Outdoor unit side view

2) Exchange

- a) Match the setting of new main PCB switches (JSW1, SW3-7) with former main PCB. (Refer to Fig.4)
- b) Turn over the separator of new heat conduction sheet and paste the heat conduction sheet on the aluminum block. (Refer to Fig.5)

3) Installation

- a) Install the new main PCB on the control and tighten the screw as shown in Fig.6.
- b) After the new Main PCB is installed on the control, reconnect the connectors, faston terminals, and round terminals to the main PCB as before. (Refer to Fig.2)  
(Confirm that the **connectors are not half inserted.**)

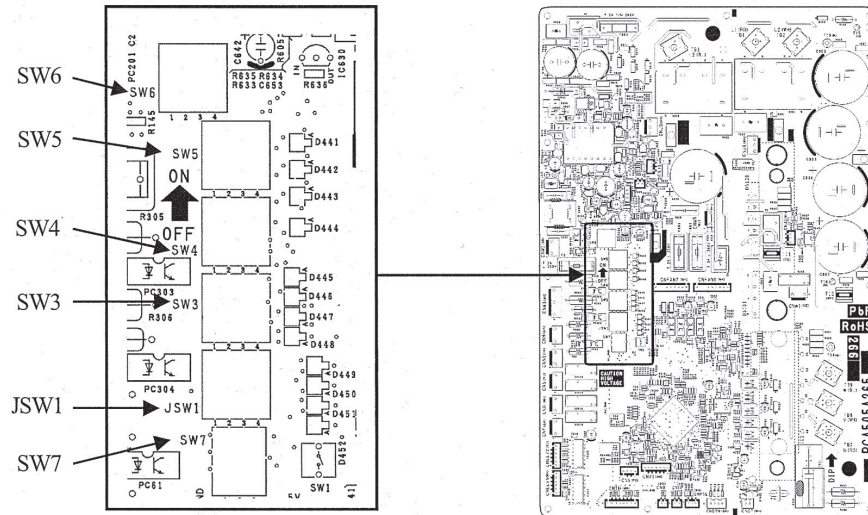

Fig.4 Switch position of main PCB

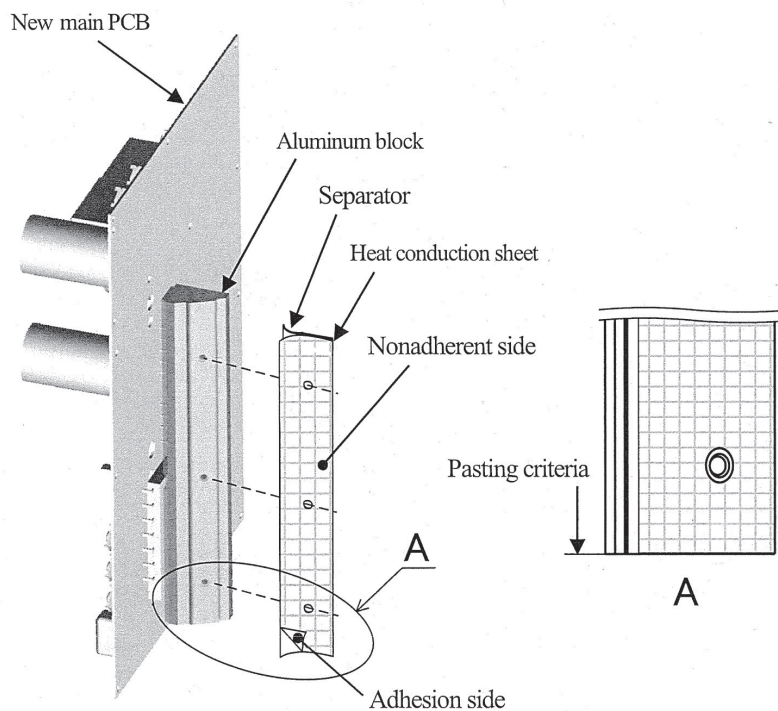

Fig.5 Detail of paste for the heat conduction sheet

**CAUTION**  
 Refrigerant piping under high pressure  
 Applicable safety equipment is required.

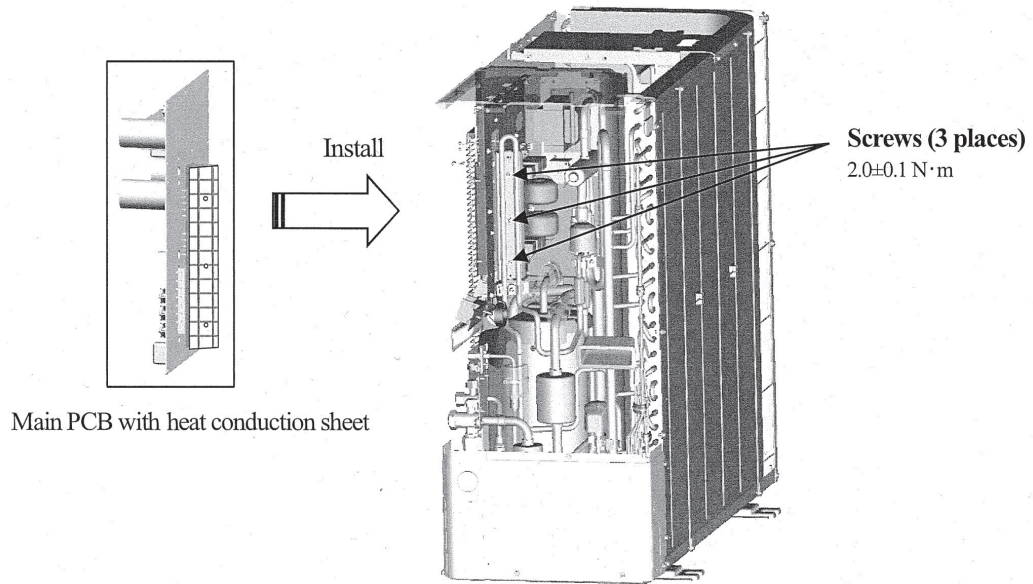
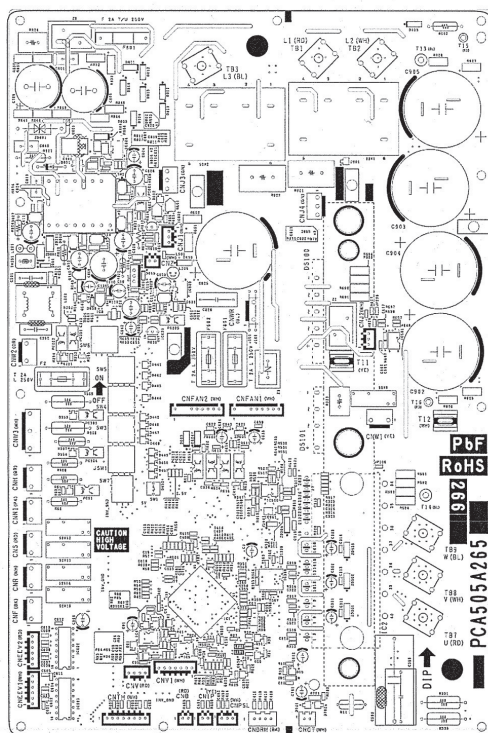

Fig.6 Installation of the main PCB

●Accessories

Check following accessories are packed in. (Except this manual)



Main PCB ×1

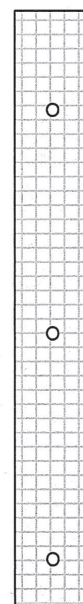

Heat conduction sheet ×1

PCA012D050

(v) Models FDC200VSA, 250VSA

Replace the control PCB according to the following procedure.

- (i) Replace the PCB **after elapsing 3 minutes from power OFF.**
- (ii) Measurement was done on both ends of connector (CNA1) during measurement, **the voltage(DC) might charged the electrolytic capacitor, be sure that the voltage is discharged sufficiently. (Refer to Fig.2)**
- (iii) Disconnect the connectors from the control PCB.
- (iv) Disconnect the white or blue wiring passing through CT1 on the PCB before replacing the PCB.
- (v) Match the setting switches (SW3-5,7, JSW1 ) with the former PCB.
- (vi) Tighten up a screw after passing white or blue wiring through CT1 of the changed.
- (vii) Please connect the connectors with the same place. **(Confirm the connectors are not half inserted.)**

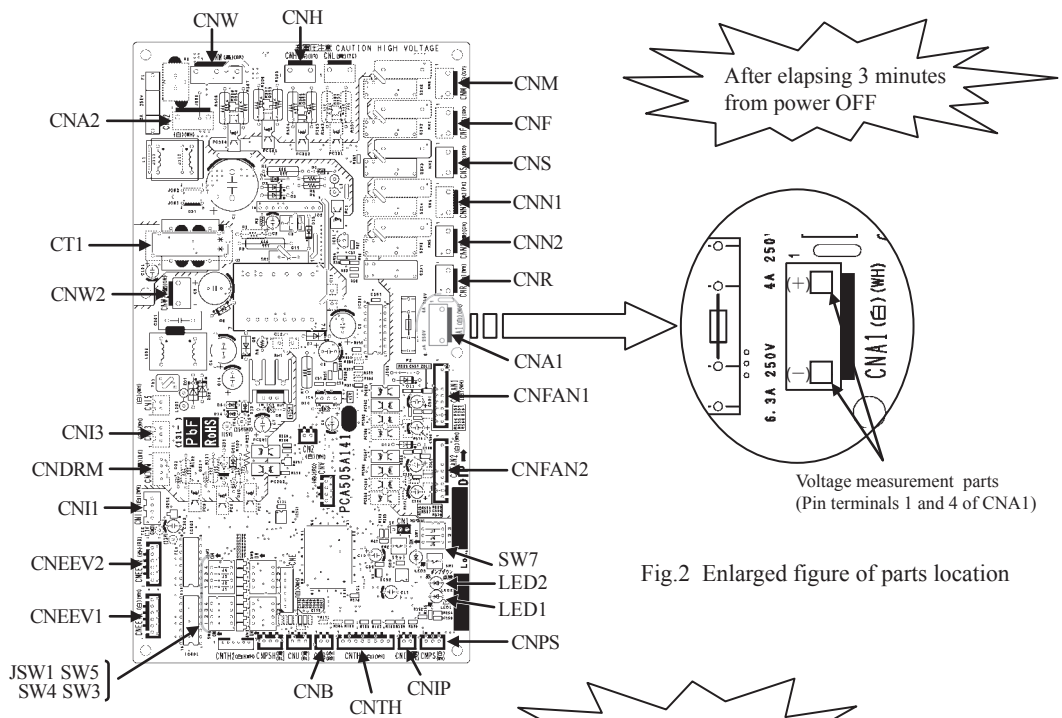

Fig.1 Parts arrangement view

Fig.2 Enlarged figure of parts location

(vi) Models FDC71VNP, 90VNP1

- 1) Shut down a power source.
- 2) Remove a top panel.(Fig.1 ①)
- 3) Detach a service panel.(Fig.1 ②)
- 4) Detach a top panel of control box.(Fig.1 ③)

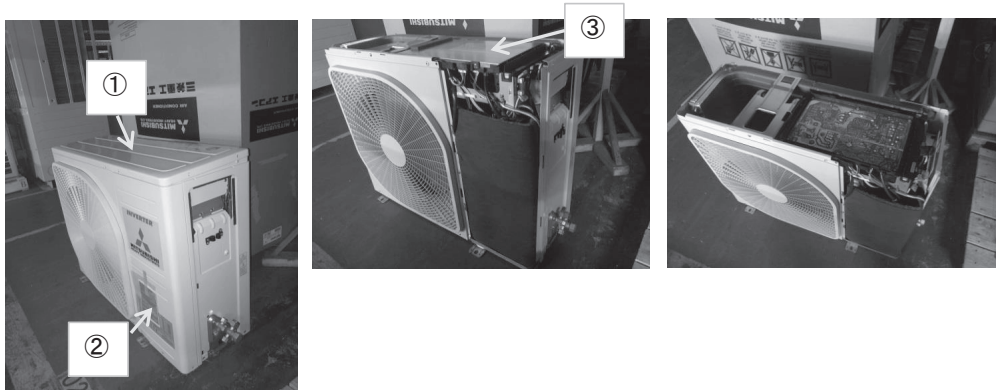

Fig.1 Outdoor unit

- 5) Make sure that 3 minutes are elapsed after shutting down a power source.
- 6) Check a voltage with the terminal of C58 by multimeter. (Fig.2)

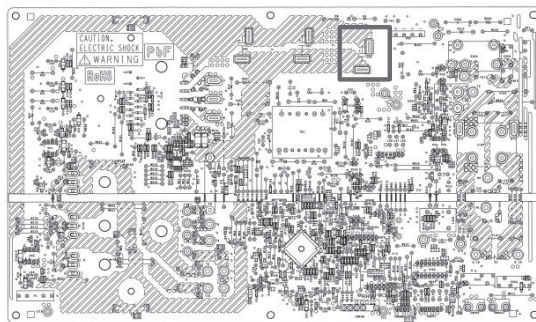

Fig.2 Terminal of C58 on PCB

- 7) Detach a cover of terminal block.(Fig.3 ④)
- 8) Detach a cover of reactor.(Fig.3 ⑤)
- 9) Remove a screw fixing a control PCB.(Fig.3 ⑥)



Fig 3. Cover of terminal block, reactor and screw of PCB

- 9) Disconnect the cable of terminal block and fuse. (Fig.4 ⑦、⑧)  
 10) Disconnect the cables of reactor. (Fig.4 ⑨)

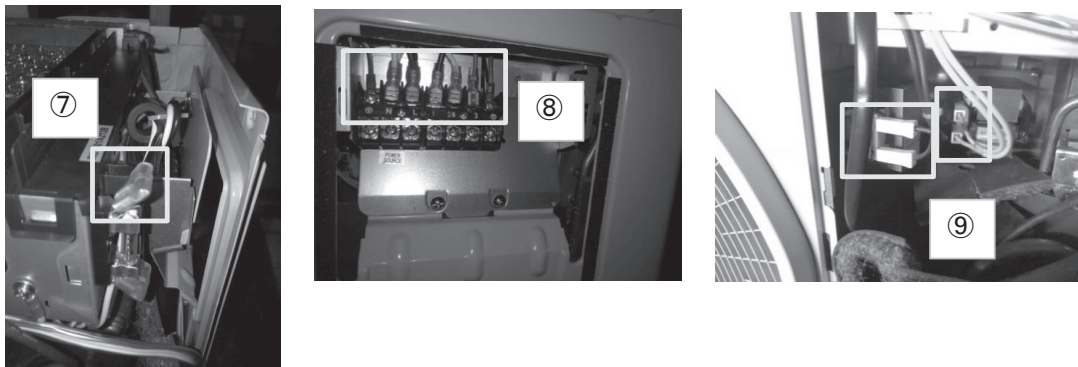

Fig.4 Cable of fuse, terminal block and reactor

- 11) Disconnect 2 earth cables on right side of control box. (Fig.5 ⑩、⑪)



Fig.5 Earth cable of control box

- 12) Disconnect CnTH(Black) on control PCB. (Fig.6 ⑫)  
 13) Disconnect a power cable of compressor (U,V,W) from control PCB. (Fig.6 ⑬)

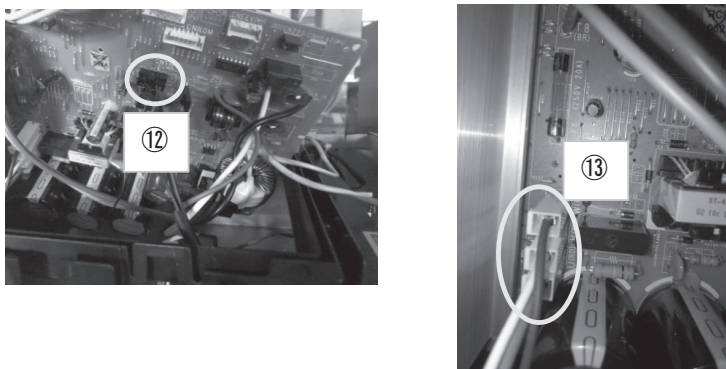

Fig.6 CnTH and power cable of compressor(U,V,W)

- 14) Take a control PCB out. (Fig.7)  
 Note: When you take a control box out, please pull it up straight.  
 Otherwise, it can be damaged.

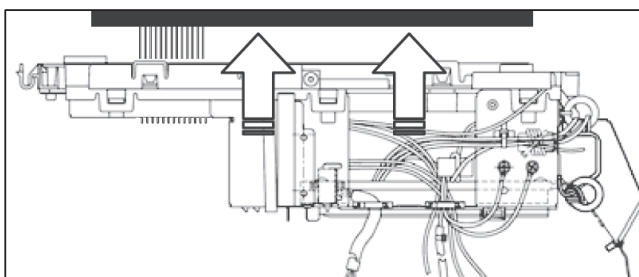

Fig.7 How to remove control PCB

15) Make sure setting of jumper on new PCB is the same with old PCB's setting. (Fig.8)

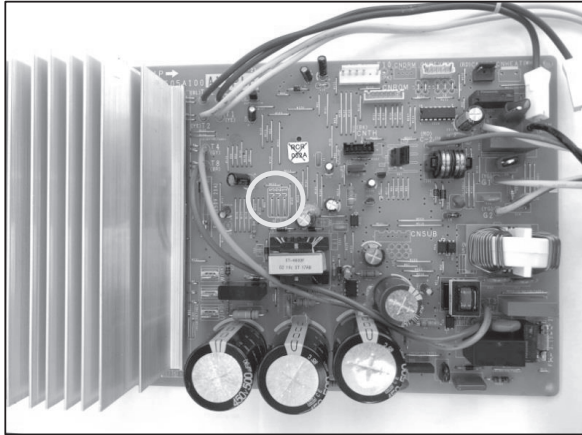

Fig.8 Setting of jumper on PCB

16) Connect the cables and connectors with the control PCB. (Confirm the **connectors are not half inserted.**)

(c) Outdoor inverter PCB replacement procedure

<b>Precautions for Safety</b>	
<ul style="list-style-type: none"> <li>Since the following precaution is the important contents for safety, be sure to observe them. WARNING and CAUTION are described as follows:</li> </ul>	<ul style="list-style-type: none"> <li><b>WARNING</b> Indicates an imminently hazardous situation which will result in death or serious injury if proper safety procedures and instructions are not adhered to.</li> <li><b>CAUTION</b> Indicates a potentially hazardous situation which may result in minor or moderate injury if proper safety procedures and instructions are not adhered to.</li> </ul>
<p><b>WARNING</b></p>	
<ul style="list-style-type: none"> <li>Securely replace the PCB according to this procedure. If the PCB is incorrectly replaced, it will cause an electric shock or fire.</li> <li>Be sure to check that the power source for the outdoor unit is turned OFF before replacing the PCB. The PCB replacement under current-carrying will cause an electric shock or fire.</li> <li>After finishing the PCB replacement, check that wiring is correctly connected with the PCB before power distribution. If the PCB is incorrectly replaced, it will cause an electric shock or fire.</li> </ul>	
<p><b>CAUTION</b></p>	
<ul style="list-style-type: none"> <li>Band the wiring so as not to tense because it will cause an electric shock.</li> </ul>	

Replace the inverter PCB according to the following procedure.

(i) Model FDC71VNX

PCA012D067B

- 1) Replace the PCB **after elapsing 3 minutes from power OFF.**  
(High voltage is retained on the capacitor after turning the power off. It is very dangerous to touch the PCB in this condition.)  
In the situation that harnesses are connected to inverter PCB **be sure to measure voltage (DC)** between T26 and T27 on inverter PCB, and **check that the voltage is discharged sufficiently.** (Refer to Fig.2).
- 2) Disconnect the connectors and faston terminals from the inverter PCB as shown in Fig. 1.
- 3) Match the setting of switches (JSW10, 11) of new PCB with former PCB.
- 4) Remove the harness bands (3 places) from the control unit, then remove the fixing screws (4places) from the radiator. (Refer to Fig.3)
- 5) Remove the inverter PCB with radiator from the control unit, and exchange the inverter PCB with radiator. Be careful not to pinch the wiring at the time of exchanging.
- 6) Fix the radiator to the control unit by screws. After exchanging the inverter PCB, reconnect the connectors, faston terminals and the harnesses as before. (Confirm that the **connectors are not half inserted.**)
- 7) Attach the harness bands (3 places), then reconnect the harnesses as before.
- 8) Install the harness clip on the inverter PCB as shown in Fig.4, and fix the harness.

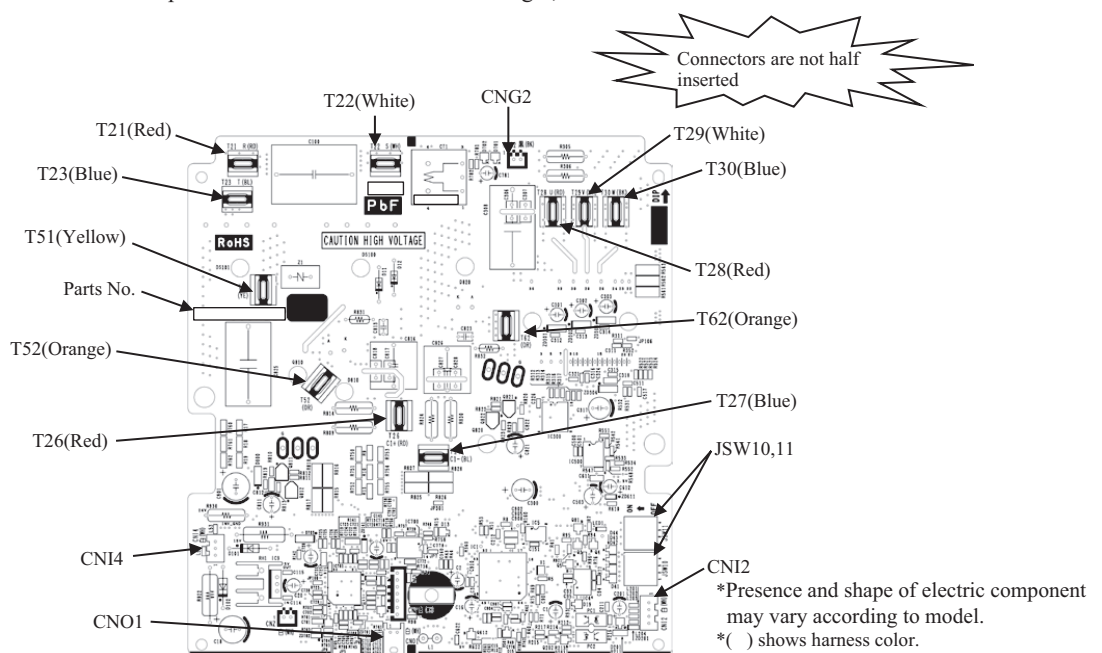

Fig.1 Parts arrangement view of inverter PCB



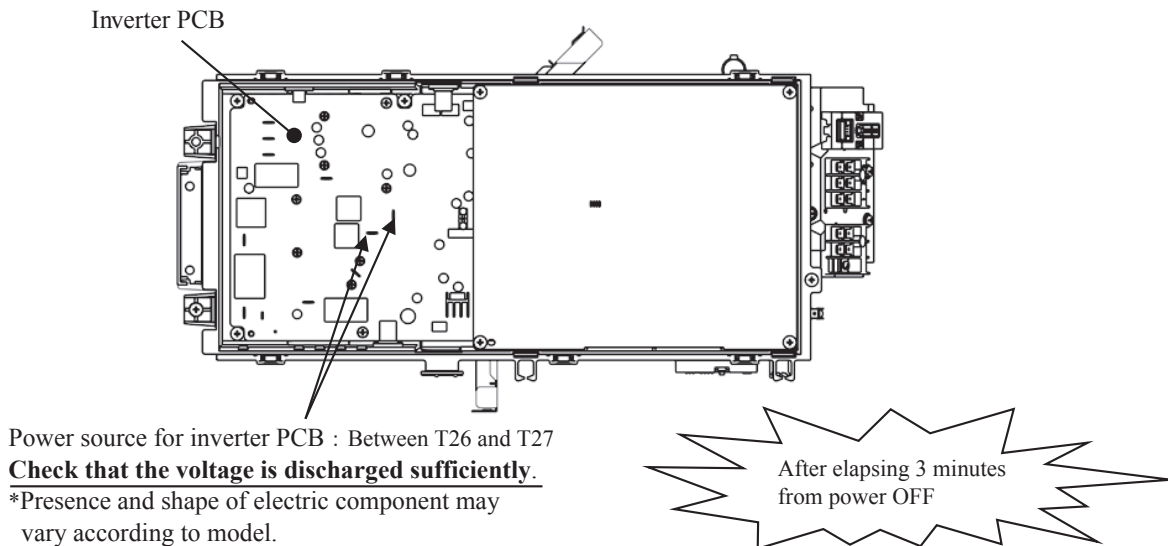

Fig.2 Voltage measurement points

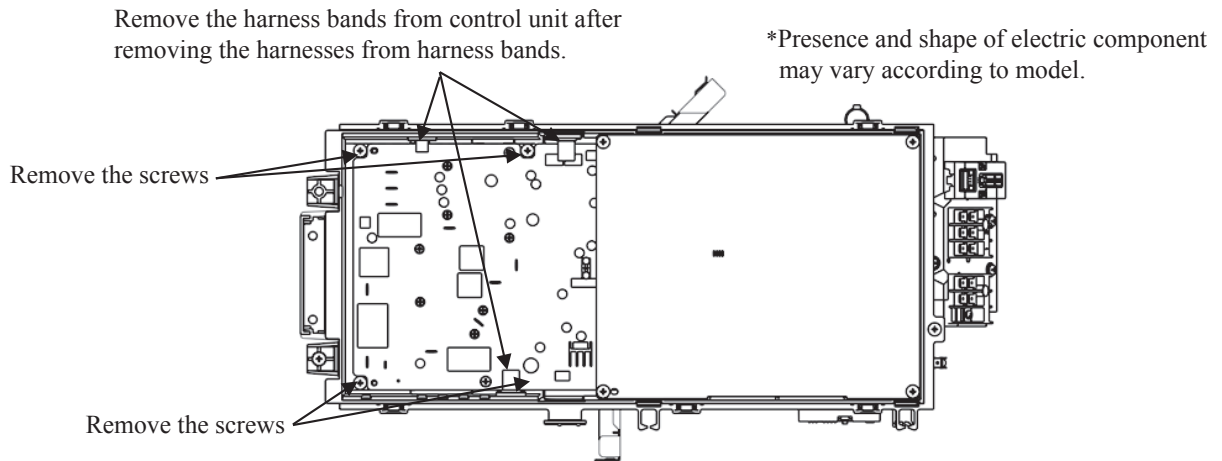

Fig.3 Target places where harness bands and screws are removed

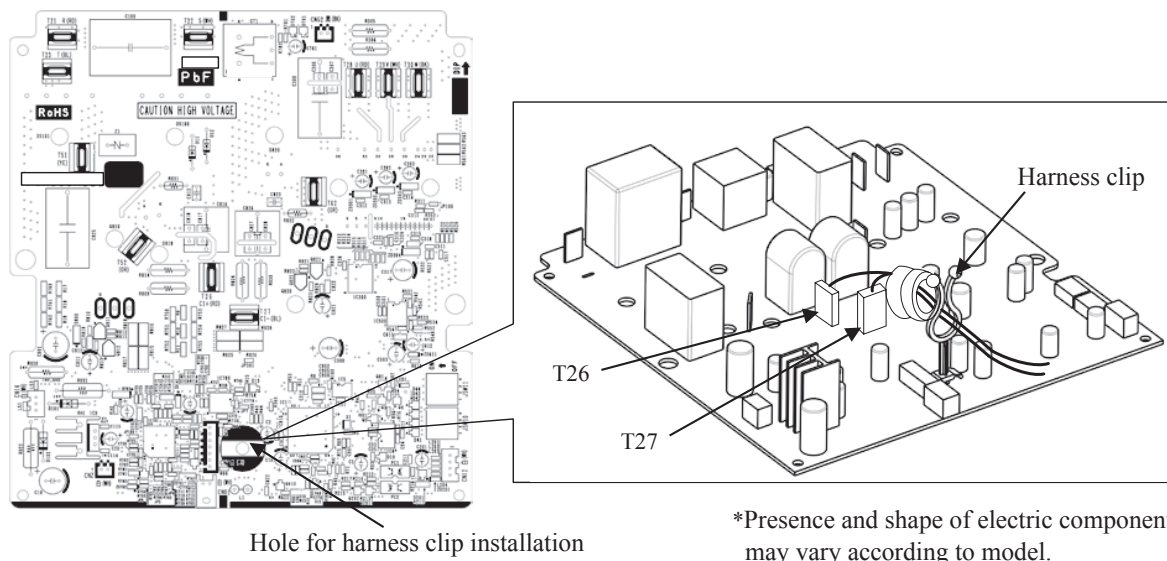
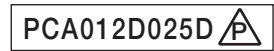

Fig.4 Fix the harness on the harness clip



(ii) Models FDC100VNX, 125VNX, 140VNX

- 1) Replace the PCB **after elapsing 3 minutes from power OFF.**  
**(Be sure to measure voltage (DC)** on both capacitor terminals located in control back, and **check that the voltage is discharged sufficiently.**(Refer to Fig.1))
- 2) Take off the connection of inverter PCB terminal block connector and remove the screw of power transistor then remove the PCB. Wipe off the silicon grease neatly on the control's radiation heat fins.
- 3) Match the setting switches (JSW10,11) of new PCB with the former PCB.
- 4) Before installing the power transistor on the new PCB, apply uniformly a bundled of silicon grease first on the surface of power transistor. Make sure it is applied to prevent damage on power transistor.
- 5) Tighten the screw of power transistor on inverter PCB and connect the terminal block. Confirm the connection and don't use soldering in the connection. Tighten properly the power transistor with a screw and make sure there is no slack. Power transistor can be damage if not properly tighten. (Recommended power transistor tightening torque: 0.98 – 1.47N·m)

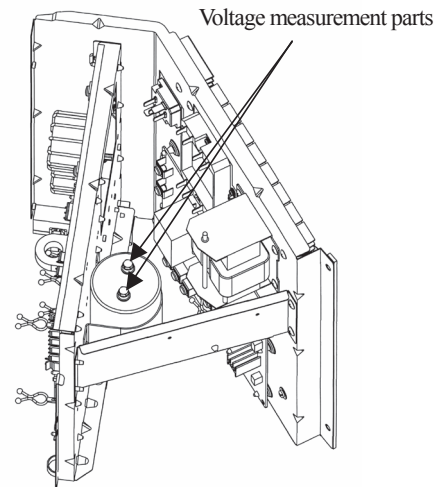
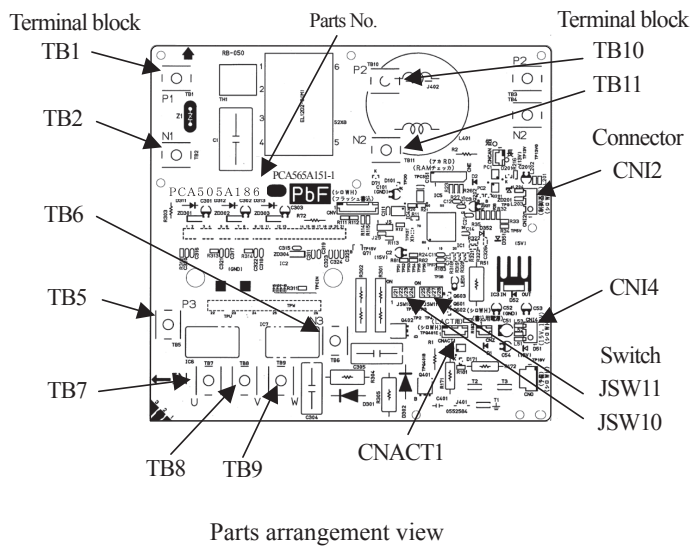
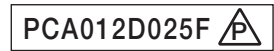

Table. 1 Switch setting  
 Models FDC100VNX, 125VNX, 140VNX

JSW10	-1	OFF	JSW11	-1	OFF
	-2	OFF		-2	OFF
	-3	OFF		-3	ON
	-4	OFF		-4	ON



(iii) Models FDC100VSX, 125VSX, 140VSX

- 1) Replace the PCB **after elapsing 3 minutes from power OFF**.  
(**Be sure to measure voltage (DC)** on both capacitor terminals located in control back, and **check that the voltage is discharged sufficiently**.(Refer to Fig.1))
- 2) Take off the connection of inverter PCB terminal block connector and remove the screw of power transistor then remove the PCB. Wipe off the silicon grease neatly on the control's radiation heat fins.
- 3) Match the setting switches (JSW10,11) of new PCB with the former PCB.
- 4) Before installing the power transistor on the new PCB, apply uniformly a bundled of silicon grease first on the surface of power transistor.Make sure it is applied to prevent damage on power transistor.
- 5) Tighten the screw of power transistor on inverter PCB and connect the terminal block.Confirm the connection and don't use soldering in the connection.Tighten properly the power transistor with a screw and make sure there is no slack.Power transistor can be damage if not properly tighten.(Recommended power transistor tightening torque:0.98 – 1.47N·m)

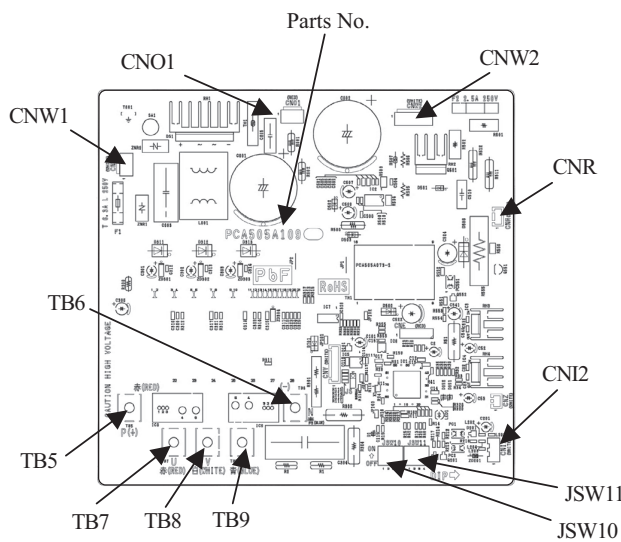

Parts arrangement view

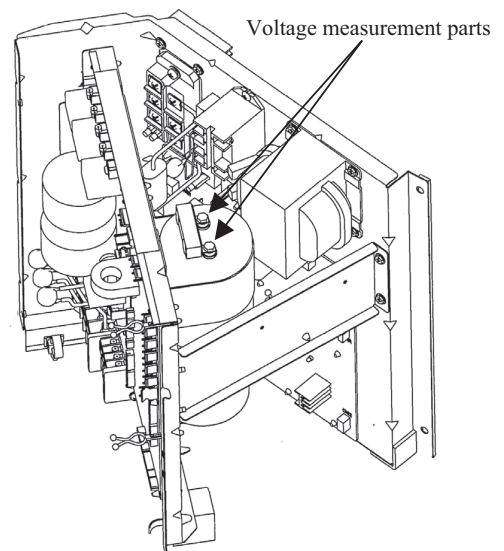

Fig.1 Position of capacitor

Table. 1 Switch setting  
Models FDC100VSX, 125VSX, 140VSX

JSW10	-1	OFF	JSW11	-1	ON
	-2	OFF		-2	OFF
	-3	OFF		-3	ON
	-4	OFF		-4	ON

PCA012D063

(iv) Model FDC200VSA

Replace the inverter PCB (Fig.1) according to the following procedure.

- 1) Replace the inverter PCB **after elapsing 3 minutes from power OFF**.  
 (Be sure to measure **voltage (DC) of two places ((A) power source for fan motor (DC), (B) power source for inverter)**, and check that **the voltage is discharged sufficiently**.(Refer to Fig.2))
- 2) Take off the wirings and connectors of inverter PCB, the screws of power transistor. Then remove the PCB from the control. Wipe off the silicon grease neatly on the control's radiation fins.
- 3) Match the setting of switches (JSW10, 11) of new PCB with the former PCB.
- 4) Before installing the new PCB to the control, **apply the bundled silicon grease uniformly** on the surface of power transistor, and all use it up at that time. **The power transistor can be damaged**, if the silicon grease is not applied.
- 5) Tighten the screws of power transistor on inverter PCB and reconnect the wirings and connectors to inverter PCB. After connection, confirm **the screws are tightened and connectors are not half inserted**.

**However, tighten the power transistor with the screws according to recommended tightening torque after tightening the screws temporarily once.**

**Power transistor can be damage** if not tightened according to this procedure.

(Temporary tightening torque:0.20 – 0.44N·m, Recommended tightening torque:0.98 – 1.47 N·m)

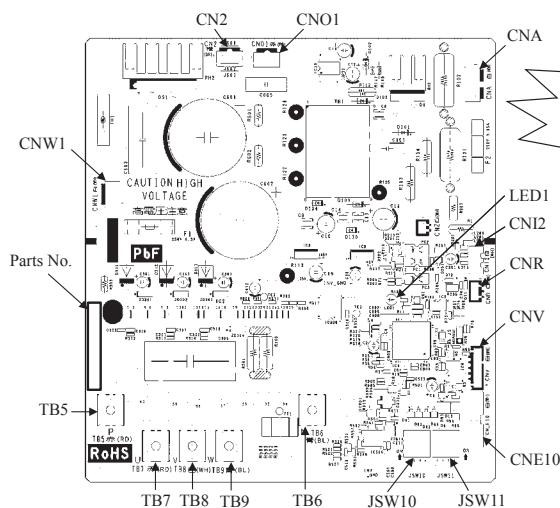

After elapsing 3 minutes from power OFF

Switch setting

JSW10	-1	OFF	JSW11	-1	OFF
	-2	OFF		-2	OFF
	-3	OFF		-3	OFF
	-4	OFF		-4	OFF

Fig.1 Parts arrangement view of inverter PCB

(A) Voltage measurement points for fan motor (DC)  
: CNA1, 1pin(+) – 4pin(-)

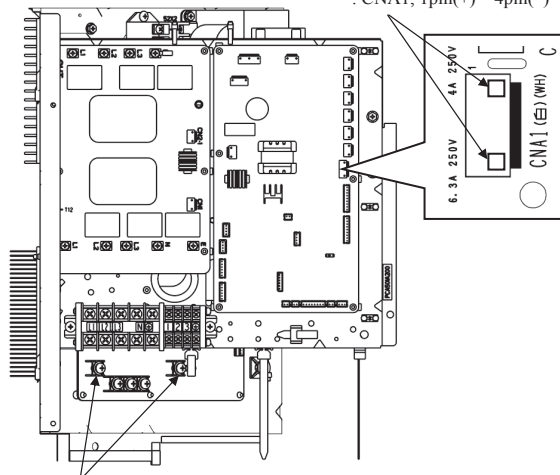

(B) Voltage measurement points for inverter  
: TB5(+) – TB6(-)

Fig.2 Voltage measurement points

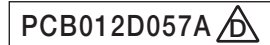

(V) Model FDC250VSA

Replace the inverter PCB (Fig.1) according to the following procedure.

- 1) Replace the PCB **after elapsing 3 minutes from power OFF.**
- 2) In the situation that harnesses are connected to control PCB, **be sure to measure voltage (DC) of two places ((A), (B))** and check that **the voltage is discharged sufficiently.** (Refer to Fig.2)
- 3) Remove the harnesses from bands, clips and connectors on the control PCB. Then, remove the appointed screws (4 places) of a control. (Refer to Fig.3)
- 4) Open main layer and **measure voltage (DC) of a place (C)** and check that **the voltage is discharged sufficiently.** (Refer to Fig.4)
- 5) Disconnect connectors from the inverter PCB (Refer to Fig.1), remove a snubber capacitor (Refer to Fig.4) and harnesses (“P”, “N”, “U”, “V” and “W”), and exchange the inverter PCB then. In the situation of being opening main layer, do not press the control from above. It will cause the product deformation or injury.
- 6) Match the setting of switches (JSW10, 11) of new PCB with former PCB.
- 7) After exchanging the inverter PCB, install the snubber capacitor to power transistor (Refer to Fig.5), and reconnect the connectors and the harnesses as before. (Confirm the **connectors are not half inserted.**)

Be careful not to pinch the wiring at the time of closing main layer. The wiring is damaged, and it will cause a short circuit or fire.

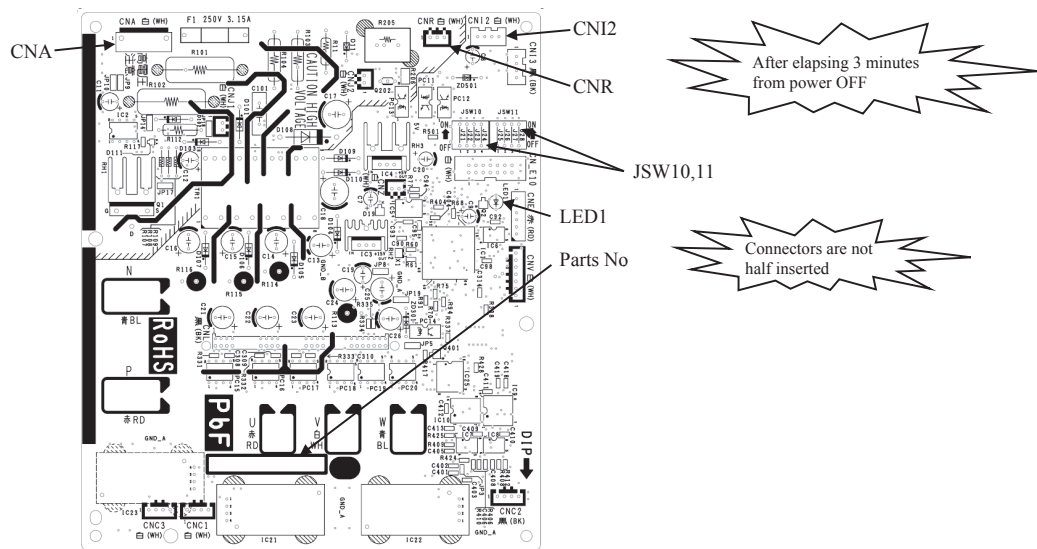
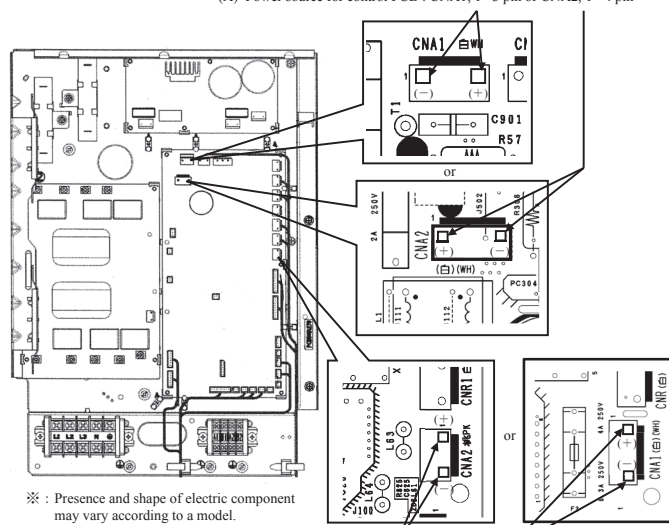

Fig.1 Parts arrangement view of inverter PCB

(A) Power source for control PCB : CNA1, 1 - 3 pin or CNA2, 1 - 4 pin



(B) Power source for fan motor (DC) : CNA2, 1 - 3 pin or CNA1, 1 - 4 pin

Fig.2 Voltage measurement points

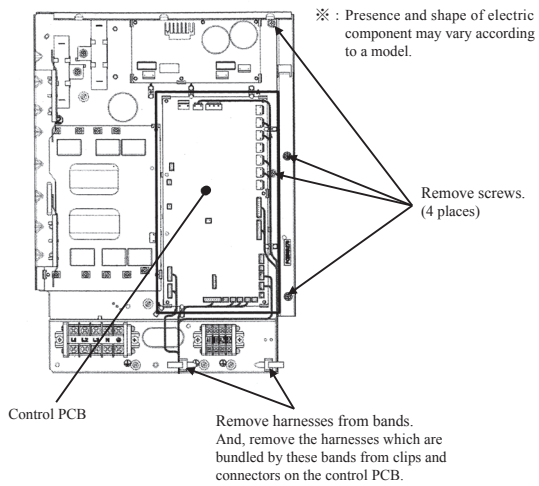

Fig.3 Target places which are removed harnesses and screws

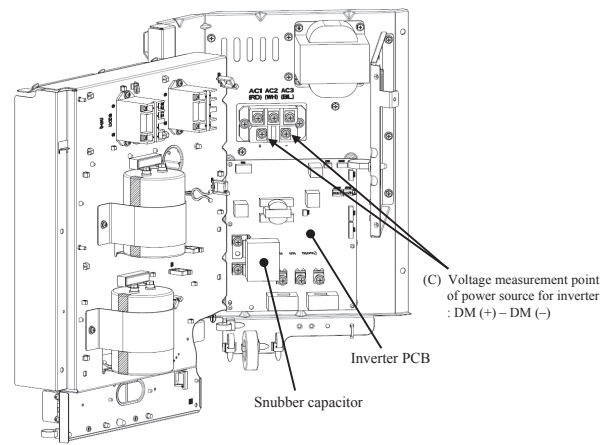
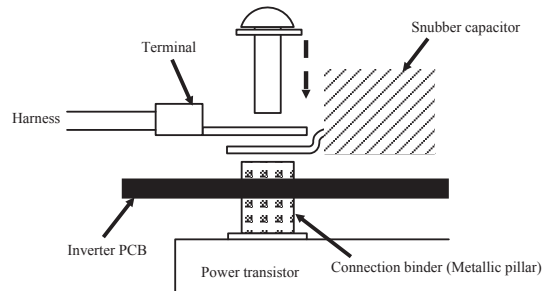

Fig.4 Installation place of inverter PCB



Procedure on tightening harness (Snubber capacitor) and power transistor with screw.  
 A metallic connection binder is set in each hole of the inverter PCB of "P", "N", "U", "V", and "W" beforehand.  
 Then tighten the harness (Snubber capacitor) and the power transistor with the screw together.  
 (Set the harness wires to be fixed to "U" and "W" with screws in respective holes after passing them through IC21 and 22.)  
 (Connect the snubber capacitor with "P" and "N".)

Fig.5 Installation method to power transistor

## ● DIP switch setting list (Outdoor unit)

Models FDC71, 100, 125, 140VNX, 100, 125, 140VSX

### (1) Control PCB

(a) Model FDC71VNX

Switch	Description	Default setting	Remark	
SW3-1	Defrost condition	Normal*/Cold region	OFF Normal	
SW3-2	Snow protection control	Normal*/Snow protection	OFF Normal	
SW3-3	Model selection	Cooling only/Heat pump*	OFF Heat pump	Keep OFF
SW3-4	Defrost prohibition time	ON: 37min*/OFF: 45min	ON 37min.	
SW4-1	Model selection	Domestic/Overseas*	ON Overseas	Keep ON
SW4-2	Model selection	3 phase/Single phase*	ON Single phase	Keep ON
SW4-3	Reserved		OFF	Keep OFF
SW4-4	Reserved		OFF	Keep OFF
SW5-1	Model selection		OFF	Keep OFF
SW5-2	Model selection		OFF	Keep OFF
SW5-3	Test run SW	Normal*/Test run	OFF Normal	
SW5-4	Test run mode	Cooling*/Heating	OFF Cooling	
SW7-1	Reserved		OFF	Keep OFF
SW7-2	Reserved		OFF	Keep OFF
SW7-3	Reserved		OFF	Keep OFF
SW8-1	Reserved		OFF	Keep OFF
SW8-2	Reserved		OFF	Keep OFF
SW8-3	Reserved		OFF	Keep OFF
SW9	Pump down operation	Normal*/Pump down	OFF Normal	

\* Default setting

(b) Models FDC100, 125, 140VNX, 100, 125, 140VSX

Switch	Description	Default setting	Remark	
SW1	Pump down operation	Normal*/Pump down	OFF Normal	
JSW1-1	Model selection	As per model	See table 1	
JSW1-2				
JSW1-3				
JSW1-4				
SW3-1	Defrost condition	Normal*/Cold region	OFF Normal	
SW3-2	Snow protection control	Normal*/Snow protection	OFF Normal	
SW3-3	Test run SW	Normal*/Test run	OFF Normal	
SW3-4	Test run mode	Cooling*/Heating	OFF Cooling	
SW4-1	Model selection	Domestic/Overseas*	ON Overseas	See table 1
SW4-2	Model selection	3 phase/Single phase	As per model	See table 1
SW4-3	Reserved		OFF	Keep OFF
SW4-4	Reserved		ON	Keep ON
SW5-1	Reserved		OFF	Keep OFF
SW5-2	Reserved		OFF	Keep OFF
SW5-3	Reserved		OFF	Keep OFF
SW5-4	Reserved		OFF	Keep OFF

\* Default setting

Table 1: Outdoor unit model selection with JSW1-1-JSW1-4 and SW4-1-SW4-2

Switch	FDC100VNX	FDC100VSX	FDC125VNX	FDC125VSX	FDC140VNX	FDC140VSX
JSW1-1	OFF	OFF	ON	ON	OFF	OFF
JSW1-2	OFF	OFF	OFF	OFF	ON	ON
JSW1-3	OFF	OFF	OFF	OFF	OFF	OFF
JSW1-4	OFF	OFF	OFF	OFF	OFF	OFF
SW4-1	ON	ON	ON	ON	ON	ON
SW4-2*	ON	OFF	ON	OFF	ON	OFF

\* 3 phase: OFF/Single phase: ON

### (2) Inverter PCB

Switch	FDC71VNX	FDC100, 125, 140VNX	FDC100, 125, 140VSX
	Single phase models	Single phase models	3 phase models
JSW10-1	OFF	OFF	OFF
JSW10-2	OFF	OFF	OFF
JSW10-3	OFF	OFF	OFF
JSW10-4	OFF *	OFF *	OFF *
JSW11-1	ON	OFF	ON
JSW11-2	ON	OFF	OFF
JSW11-3	ON	ON	ON
JSW11-4	ON	ON	ON

\* When checking inverter PCB of FDC71 – 140 models with inverter checker, turn JSW10-4 ON.

(Regarding the checking method of inverter PCB with inverter checker, refer to page 63, 65, 66 for details)

**Models FDC100, 125, 140VNA, 100, 125, 140VSA**

Switch	Description	Default setting	Remark
SW1	(See table 1)	OFF	
JSW1-1	Model selection	As per model	See table 2
JSW1-2			
JSW1-3			
JSW1-4	Reserved	OFF	Keep OFF
SW3-1	Defrost condition	OFF	Refer to page 34
SW3-2	Snow protection control	OFF	Refer to page 32
SW3-3	Test run SW	OFF	Refer to page 38
SW3-4	Test run mode	OFF	Refer to page 38
SW4-1	Reserved	OFF	Keep OFF
SW4-2	Cancel measuring of refrigerant leak	OFF	Detection function of error in E57 refrigeration system protection (OFF: Detection / ON: Cancel to detect)
SW4-3	Reserved	OFF	Keep OFF
SW4-4	Reserved	OFF	Keep OFF
SW5-1	Utilization of existing piping control	OFF	See Note 1
SW5-2	Height difference of IU and OU control	OFF	When the outdoor unit is positioned higher than 30m (OFF : Normal / ON : high head)
SW5-3	Reserved	OFF	Keep OFF
SW5-4	Reserved	OFF	Keep OFF
SW6-1	Reserved	OFF	Keep OFF
SW6-2	Reserved	OFF	Keep OFF
SW6-3	Reserved	OFF	Keep OFF
SW6-4	Inverter checker mode	OFF	Refer to page 78
SW7-1	SW1 function selection	OFF	See table1
SW7-2	Frost protection by frequent external ON/OFF	OFF	In case external device switches ON/OFF frequently, switch to ON to start defrost operation even though short operation time.
SW7-3	Silent mode selection	OFF	Refer to page 38

\* Default setting

Table 1: SW1 function selection

0: OFF 1: ON

SW7-1	SW1 function	Remark
0	Pump down operation	Refer to page 38
1	Reset cumulative time of compressor operation	Reset of operation time after replacing a compressor

Table 2: Outdoor unit model selection with JSW1-1-JSW1-3

	100VNA	100VSA	125VNA	125VSA	140VNA	140VSA
JSW1-1	0	0	1	1	0	0
JSW1-2	0	0	0	0	1	1
JSW1-3	0	0	0	0	0	0

Note 1: Utilization of existing pipe

- In case of reusing annealed pipe  $\phi 19.05 \times t1.0$ , be sure to turn the DIP switch on the outdoor PCB ON as shown in the table because of its insufficient strength. If its material is 1/2H or its thickness is 1.2mm or more it is no necessary.
- If bending radius of existing pipe is less than R70mm, be sure to turn the DIP switch on the outdoor PCB shown in the table due to its insufficient strength.



**Models FDC200, 250VSA****(1) Control PCB**

Switch	Description		Default setting		Remark
SW1	Pump down operation	Normal*/Pump down	OFF	Normal	
JSW1-1	Model selection		As per model		See table 1
JSW1-2					
JSW1-3					
JSW1-4					
SW3-1	Defrost condition	Normal*/Cold region	OFF	Normal	
SW3-2	Snow protection control	Normal*/Snow protection	OFF	Normal	
SW3-3	Test run SW	Normal*/Test run	OFF	Normal	
SW3-4	Test run mode	Cooling*/Heating	OFF	Cooling	
SW4-1	Model selection	Domestic/Overseas*	ON	Overseas	See table 1
SW4-2	Model selection	3 phase/Single phase	As per model		See table 1
SW4-3	Reserved		OFF		Keep OFF
SW4-4	Reserved		OFF		Keep OFF
SW5-1	Utilization of existing piping control	Normal*/Existing piping control	OFF		Keep OFF
SW5-2	Reserved		OFF		Keep OFF
SW5-3	Reserved		OFF		Keep OFF
SW5-4	Reserved		OFF		Keep OFF
SW7-1	Silent mode setting	Capacity priority/Silent priority	ON	Silent priority	
SW7-2	Reserved		ON		Keep ON
SW7-3	Anti frost control	Invalid/Valid	ON	Valid	

\* Default setting

Table 1: Outdoor unit model selection with JSW1-1-JSW1-4 and SW4-1-SW4-2

Switch	FDC200	FDC250
JSW1-1	ON	OFF
JSW1-2	ON	OFF
JSW1-3	OFF	ON
JSW1-4	OFF	OFF
SW4-1	ON	ON
SW4-2	OFF	OFF

**(2) Inverter PCB**

Switch	FDC200	FDC250
JSW10-1	OFF	OFF
JSW10-2	OFF	ON
JSW10-3	OFF	OFF
JSW10-4	OFF *	OFF *
JSW11-1	OFF	OFF
JSW11-2	OFF	OFF
JSW11-3	OFF	OFF
JSW11-4	OFF	OFF

\* When checking inverter PCB of FDC200, 250 models with inverter checker, turn JSW10-4 ON.

(Regarding the checking method of inverter PCB with inverter checker, refer to page 67, 68 for details)

**(5) Check of anomalous operation data with the remote control**

**(a) In case of RC-EX3A remote control**

[Operating procedure]

① On the TOP screen, touch the buttons in the order of “Menu” → “Service setting” → “Service & Maintenance” → “Service password” → “Set” → “Error display” → “Error history”.

② When only one indoor unit is connected to the remote control, followings will be displayed.

1. When there is any anomaly: “Loading. Wait a while” is displayed, followed by the operation data at the occurrence of anomaly

Contents of display

- Error code
- Number and data item

2. When there is no anomaly: “No anomaly” is displayed, and this mode is terminated.

③ When two or more indoor units are connected to the remote control, followings will be displayed.

1. When there is any anomaly: If the unit having anomaly is selected on the “Select IU” screen, “Loading. Wait a while” is displayed, followed by the operation data at the occurrence of anomaly.

Contents of display

- Indoor unit No.
- Error code
- Number and data item

2. When there is no anomaly: “No anomaly” is displayed, and this mode is terminated.

Note (1) When the number of connected units cannot be shown in a page, select “Next”.

④ If you press [RUN/STOP] button, the display returns to the TOP screen.

◎ **If you touch “Back” button on the way of setting, the display returns to the last precious screen.**

Note (1) When two remote controls are used to control indoor units, the check of anomaly operation data can be made on the master remote control only. (It cannot be operated from the slave remote control.)

■ Anomaly operation data (Corresponding data may not be provided depending on models. Such items will not be displayed.)

Number	Data Item
01	非 (Operation Mode)
02	SET TEMP (Set Temperature)
03	RETURN AIR (Return Air Temperature)
04	SENSOR (Remote Control Temperature Sensor)
05	TH-R1 (Indoor Heat Exchanger Temperature Sensor / U Bend)
06	TH-R2 (Indoor Heat Exchanger Temperature Sensor / Capillary)
07	TH-R3 (Indoor Heat Exchanger Temperature Sensor / Gas Header)
08	I/U FANSPEED (Indoor Unit Fan Speed)
09	DEMAND Hz (Frequency Requirements)
10	ANSWER Hz (Response Frequency)
11	I/U EEV P (Pulse of Indoor Unit Expansion Valve)
12	TOTAL I/U RUN H (Total Running Hours of The Indoor Unit)
13	SUPPLY AIR (Supply Air Temperature)
21	OUTDOOR (Outdoor Air Temperature)
22	THO-R1 (Outdoor Heat Exchanger Temperature Sensor)
23	THO-R2 (Outdoor Heat Exchanger Temperature Sensor)
24	COMP Hz (Compressor Frequency)
25	HP MPa (High Pressure)
26	LP MPa (Low Pressure)
27	Td (Discharge Pipe Temperature)
28	COMP BOTTOM (Comp Bottom Temperature)
29	CT AMP (Current)
30	TARGET SH (Target Super Heat)
31	SH (Super Heat)
32	TDSH (Discharge Pipe Super Heat)
33	PROTECTION No. (Protection State No. of The Compressor)
34	O/U FANSPEED (Outdoor Unit Fan Speed)
35	63H1 (63H1 On/Off)
36	DEFROST (Defrost Control On/Off)
37	TOTAL COMP RUN H (Total Running Hours of The Compressor)
38	O/U EEV1 P (Pulse of The Outdoor Unit Expansion Valve EEVC)
39	O/U EEV2 P (Pulse of The Outdoor Unit Expansion Valve EEVH)

**●Number 33 Details of compressor protection status No. Models FDC71, 100, 125, 140VNX, 100, 125, 140VSX**

No.	Contents of display	Reference page
"0"	Normal	
"1"	Discharge pipe temperature protection control	P.34, (6).(a).(i)
"2"	Discharge pipe temperature anomaly	P.34, (6).(a).(ii)
"3"	Current safe control of inverter primary current	P.36, (6).(g)
"4"	High pressure protection control	P.34, (6).(b).(i), P.35, (6).(c).(i)
"5"	High pressure anomaly	P.34, (6).(b).(ii)
"6"	Low pressure protection control	P.35, (6).(e).(i)
"7"	Low pressure anomaly	P.35, (6).(e).(ii)
"8"	Anti-frost prevention control	P.36, (6).(k)
"9"	Current cut	P.36, (6).(g)
"10"	Power transistor protection control	P.36, (6).(h)
"11"	Power transistor anomaly (Overheat)	P.36, (6).(i)
"12"	Compression ratio control	P.35, (6).(f)
"13"	Spare	
"14"	Dewing prevention control	P.37, (6).(l)
"15"	Current safe control of inverter secondary current	P.36, (6).(g)
"16"	Stop by compressor rotor lock	
"17"	Stop by compressor startup failure	P.37, (6).(p)
"18"	Active filter anomaly	

Note(1) Operation data display on the remote control.

- Data is displayed until canceling the protection control.
- In case of multiple protections controlled, only the younger No. is displayed.

Note(2) Common item.

- ① In heating mode.  
During protection control by the command signal for reducing compressor frequency from indoor unit, No. "4" is displayed.
- ② In cooling and dehumidifying mode.  
During protection control by the command signal for reducing compressor frequency from indoor unit, No. "8" is displayed.

**Models FDC100, 125, 140VNA, 100, 125, 140VSA**

No.	Contents of display	Reference Page
"0"	Normal	
"1"	Discharge pipe temperature protection control	P.177, (6).(a).(i)
"2"	Discharge pipe temperature anomaly	P.177, (6).(a).(ii)
"3"	Current safe control of inverter primary current	P.178, (6).(f)
"4"	High pressure protection control	P.177, (6).(b).(i), (c).(i)
"5"	High pressure anomaly	P.177, (6).(b).(ii)
"8"	Anti-frost prevention control	P.179, (6).(j)
"9"	Current cut	P.178, (6).(f)
"11"	Power transistor anomaly (Overheat)	P.179, (6).(h)
"12"	Compression ratio control	P.178, (6).(e)
"13"	Spare	
"14"	Dewing prevention control	P.179, (6).(k)
"15"	Current safe control of inverter secondary current	P.178, (6).(f)
"16"	Stop by compressor rotor lock	
"17"	Stop by compressor startup failure	P.180, (6).(o)
"18"	Active filter anomaly	

Note(1) Operation data display on the remote control.  
 •Data is displayed until canceling the protection control.  
 •In case of multiple protections controlled, only the younger No. is displayed.  
 Note(2) Common item.  
 ① In heating mode.  
 During protection control by the command signal for reducing compressor frequency from indoor unit, No. "4" is displayed.  
 ② In cooling and dehumidifying mode.  
 During protection control by the command signal for reducing compressor frequency from indoor unit, No. "8" is displayed.

**Models FDC200, 250VSA**

No.	Contents of display	Reference page
"0"	Normal	
"1"	Discharge pipe temperature protection control	P.187, (6).(a).(i)
"2"	Discharge pipe temperature anomaly	P.187, (6).(a).(ii)
"3"	Current safe control of inverter primary current	P.189, (6).(g)
"4"	High pressure protection control	P.187, (6).(b).(i), P.187, (6).(c).(i)
"5"	High pressure anomaly	P.187, (6).(b).(ii)
"6"	Low pressure protection control	P.188, (6).(e).(i)
"7"	Low pressure anomaly	P.188, (6).(e).(ii)
"8"	Anti-frost prevention control	P.189, (6).(k)
"9"	Current cut	P.189, (6).(g)
"10"	Power transistor protection control	P.189, (6).(h)
"11"	Power transistor anomaly (Overheat)	P.189, (6).(i)
"12"	Compression ratio control	P.188, (6).(f)
"13"	Spare	
"14"	Dewing prevention control	P.190, (6).(l)
"15"	Current safe control of inverter secondary current	P.189, (6).(g)
"16"	Stop by compressor rotor lock	
"17"	Stop by compressor startup failure	P.190, (6).(p)
"18"	Active filter anomaly	

Note(1) Operation data display on the remote control.  
 •Data is displayed until canceling the protection control.  
 •In case of multiple protections controlled, only the younger No. is displayed.  
 Note(2) Common item.  
 ① In heating mode.  
 During protection control by the command signal for reducing compressor frequency from indoor unit, No. "4" is displayed.  
 ② In cooling and dehumidifying mode.  
 During protection control by the command signal for reducing compressor frequency from indoor unit, No. "8" is displayed.

**Models FDC71VNP, 90VNP(1)**

No.	Contents of display	Reference page
"0"	Normal	
"1"	Discharge pipe temperature protection control	P207, (11). (b). (i)
"2"	Discharge pipe temperature anomaly	P207, (11). (b). (ii)
"3"	Current safe control of inverter primary current	P208, (12)
"4"	High pressure protection control	P205, (6). (c), P206, (8), (b)
"5"	High pressure anomaly	P207, (11)
"8"	Anti-frost prevention control	
"9"	Current cut	P208, (13)
"11"	Power transistor anomaly (Overheat)	
"12"	Compression ratio control	
"13"	Spare	
"14"	Dewing prevention control	
"15"	Current safe control of inverter secondary current	
"16"	Stop by compressor rotor lock	
"17"	Stop by compressor startup failure	
"18"	Active filter anomaly	

Note(1) Operation data display on the remote control.  
 •Data is displayed until canceling the protection control.  
 •In case of multiple protections controlled, only the younger No. is displayed.  
 Note(2) Common item.  
 ① In heating mode.  
 During protection control by the command signal for reducing compressor frequency from indoor unit, No. "4" is displayed.  
 ② In cooling and dehumidifying mode.  
 During protection control by the command signal for reducing compressor frequency from indoor unit, No. "8" is displayed.

**Model FDC100VNP**

No.	Contents of display	Reference page
"0"	Normal	
"1"	Discharge pipe temperature protection control	P215, (12). (b). (i)
"2"	Discharge pipe temperature anomaly	P215, (12). (b). (ii)
"3"	Current safe control of inverter primary current	P215, (13)
"4"	High pressure protection control	P213, (6). (c), P214, (8), (b)
"5"	High pressure anomaly	P215, (12)
"6"	Low pressure protection control	P213.(7), P215, (11)
"8"	Anti-frost prevention control	
"9"	Current cut	P216, (14)
"13"	Spare	
"15"	Current safe control of inverter secondary current	
"16"	Stop by compressor rotor lock	
"17"	Stop by compressor startup failure	
"18"	Active filter anomaly	

Note(1) Operation data display on the remote control.  
 •Data is displayed until canceling the protection control.  
 •In case of multiple protections controlled, only the younger No. is displayed.  
 Note(2) Common item.  
 ① In heating mode.  
 During protection control by the command signal for reducing compressor frequency from indoor unit, No. "4" is displayed.  
 ② In cooling and dehumidifying mode.  
 During protection control by the command signal for reducing compressor frequency from indoor unit, No. "8" is displayed.

**(b) In case of RC-E5 remote control**

Operation data can be checked with remote control unit operation.

- ① Press the **CHECK** button.  
The display change “ OPER DATA ▼ ”
- ② Press the **(SET)** button while “ OPER DATA ▼ ” is displayed.

- ③ When only one indoor unit is connected to remote control, “ DATA LOADING ” is displayed (blinking indication during data loading).

Next, operation data of the indoor unit will be displayed.  
Skip to step ⑦.

- ④ When plural indoor units is connected, the smallest address number of indoor unit among all connected indoor unit is displayed.

[Example]:

“ SELECT I/U ” (blinking 1 seconds) → “ I/U000 ▲ ” blinking.

- ⑤ Select the indoor unit number you would like to have data displayed with the **▲ ▼** button.

- ⑥ Determine the indoor unit number with the **(SET)** button.

(The indoor unit number changes from blinking indication to continuous indication)

“ I/U000 ” (The address of selected indoor unit is blinking for 2 seconds.)



“ DATA LOADING ” (A blinking indication appears while data loaded.)

Next, the operation data of the indoor unit is indicated.

- ⑦ Upon operation of the **▲ ▼** button, the current operation data is displayed in order from data number 01. The items displayed are in the above table.

\*Depending on models, the items that do not have corresponding data are not displayed.

- ⑧ To display the data of a different indoor unit, press the **AIR CON No.** button, which allows you to go back to the indoor unit selection screen.

- ⑨ Pressing the **ON/OFF** button will stop displaying data.

Pressing the **(RESET)** button during remote control unit operation will undo your last operation and allow you to go back to the previous screen.

Ⓞ If two (2) remote controls are connected to one (1) inside unit, only the master control is available for trial operation and confirmation of operation data. (The slave remote control is not available.)

**● Number 33 Details of compressor protection statu:**

Refer to page 73 and 74.

Number		Data Item
01		(Operation Mode)
02	SET TEMP	(Set Temperature)
03	RETURN AIR	(Return Air Temperature)
04	SENSOR	(Remote Control Temperature Sensor)
05	THI-R1	(Indoor Heat Exchanger Temperature Sensor / U Bend)
06	THI-R2	(Indoor Heat Exchanger Temperature Sensor /Capillary)
07	THI-R3	(Indoor Heat Exchanger Temperature Sensor /Gas Header)
08	I/U FANSPEED	(Indoor Unit Fan Speed)
09	DEMAND Hz	(Frequency Requirements)
10	ANSWER Hz	(Response Frequency)
11	I/U EEV P	(Pulse of Indoor Unit Expansion Value)
12	TOTAL I/U RUN H	(Total Running Hours of The Indoor Unit)
21	OUTDOOR	(Outdoor Air Temperature)
22	THO-R1	(Outdoor Heat Exchanger Temperature Sensor)
23	THO-R2	(Outdoor Heat Exchanger Temperature Sensor)
24	COMP Hz	(Compressor Frequency)
25	HP MPa	(High Pressure)
26	LP MPa	(Low Pressure)
27	Td	(Discharge Pipe Temperature)
28	COMP BOTTOM	(Compressor Bottom Temperature)
29	CT AMP	(Current)
30	TARGET SH	(Target Super Heat)
31	SH	(Super Heat)
32	TDSH	(Discharge Pipe Super Heat)
33	PROTECTION No.	(Protection State No. of The Compressor)
34	O/U FANSPEED	(Outdoor Unit Fan Speed)
35	63H1	(63H1 On/Off)
36	DEFROST	(Defrost Control On/Off)
37	TOTAL COMP RUN H	(Total Running Hours of The Compressor)
38	O/U EEV1 P	(Pulse of The Outdoor Unit Expansion Valve EEVC)
39	O/U EEV2 P	(Pulse of The Outdoor Unit Expansion Valve EEVH)

(6) Power transistor module (Including the driver PCB) inspection procedure

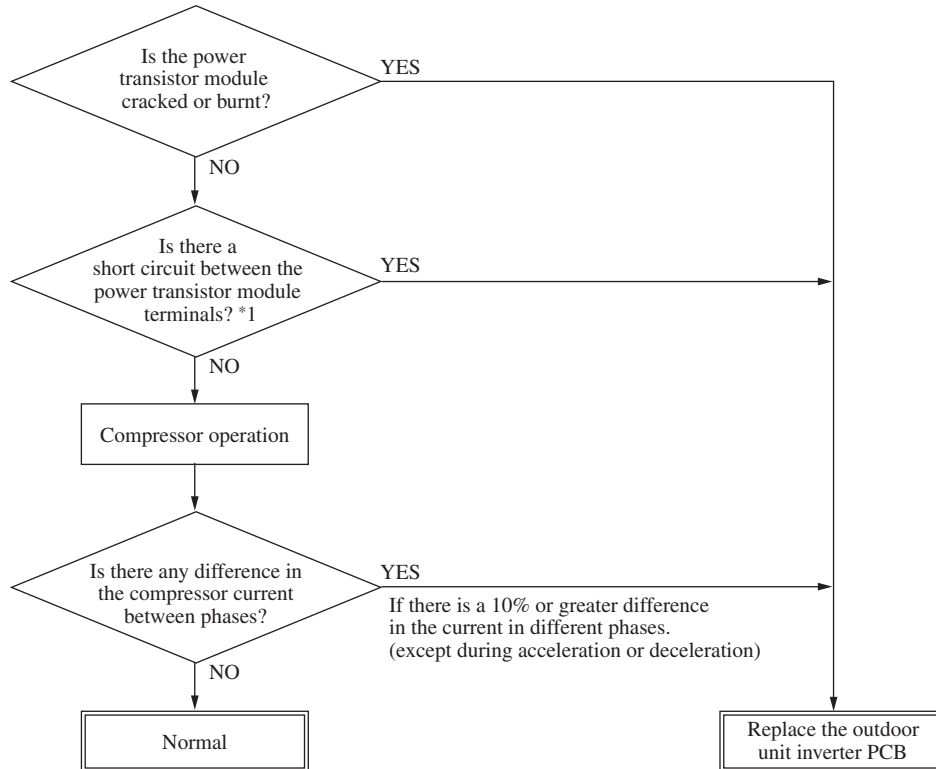

\*1 Power transistor module terminal short circuit check procedure

Disconnect the compressor wiring, then conduct a short circuit check.

P-U, P-V, P-W

N-U, N-V, N-W

Check between the P-N terminals.

Bring the tester probes in contact with the following places on each terminal.

P: Power transistor P terminal,

N: Power transistor N terminal,

U: End of red harness to compressor

V: End of white harness to compressor

W: End of black or blue harness to compressor

Check for a power transistor short circuit.

- When you do not have a diagnostic checker for judging if the inverter is defective, measure between the terminals of the power transistor parts, judge whether the power transistor is defective or not.
- Disconnect the compressor, then measure with the control incorporated.

Models FDC71-140VNX, 100-140VSX

Tester		Normal value (Ω)	
Terminal (+)	Terminal (-)	Model FDC71	Model FDC100-140
P	N	0 - (Numerical value rises.)	Approx. 1 M Approx. 300-400
N	P		
P	U	Several M (Numerical value rises.)	0
P	V		
P	W		
N	U	Approx. 650 k	Approx. 1.2 M
N	V		
N	W		
U	P	Approx. 670 k	Approx. 1.3 M
V	P	Approx. 4.4 M	
W	P	Approx. 4.4 M	
U	N	Approx. 650 k	0
V	N	Approx. 4.8 M	
W	N	Approx. 4.9 M	

If the measured values range from 0 - several kW, there is a possibility that the elements are damaged, so replace the power transistor parts.

**Models FDC100-140VNA, 100-140VSA**

Tester		Normal value ( $\Omega$ )	
Terminal (+)	Terminal (-)	Models FDC100-140VNA	Models FDC100-140VSA
P	N	Approx. 750 k	Approx. 200 k
N	P	Approx. 400 k	
P	U	Approx. 950 k	Approx. 450 k
P	V		
P	W		
N	U	Approx. 240 k	Approx. 250 k
N	V		
N	W		
U	P	Approx. 890 k	Approx. 250 k
V	P		
W	P		
U	N	Approx. 240 k	Approx. 450 k
V	N		
W	N		

If the measured values range from 0 - several kW, there is a possibility that the elements are damaged, so replace the power transistor parts.

**Models FDC200, 250VSA**

Tester		Normal value ( $\Omega$ )	
Terminal (+)	Terminal (-)	Model FDC200	Model FDC250
P	N	Scores of M	Scores of M
N	P	Approx. 4.5M	Approx. 8.9M
P	U	Scores of M	Scores of M
P	V		
P	W		
N	U	Approx. 130k	Approx. 4.6M
N	V		
N	W		
U	P	Approx. 4.5M	Approx. 4.8M
V	P		
W	P		
U	N	Approx. 6.7M	Scores of M
V	N	Approx. 6.0M	
W	N	Approx. 5.7M	

If the measured values range from 0 - several kW, there is a possibility that the elements are damaged, so replace the power transistor parts.

**Models FDC71-100VNP**

Tester		Normal value ( $\Omega$ )	Diode mode (V)
Terminal (+)	Terminal (-)		
P	N	A few of $M\Omega$ (Not short)	—
N	P		
P	U		
P	V		
P	W		
N	U		
N	V		Approx. 0.4V
N	W		
U	P		
V	P		
W	P		
U	N		
V	N	—	
W	N		

If the measured values range from 0 - several k $\Omega$ , there is a possibility that the elements are damaged, so replace the power transistor parts.

**(7) Inverter checker for diagnosis of inverter output**

**Models FDC71, 100, 125, 140VNX, 100, 125, 140VSX**

**FDC100, 125, 140VNA, 100, 125, 140VSA, 200, 250VSA, FDC71-100VNP**

● Checking method

(a) Model FDC100VNP

(i) Setup procedure of checker.

- 1) Power OFF (Turn off the breaker).
- 2) Remove the terminal cover of compressor and disconnect the wires (U, V, W) from compressor.
- 3) Connect the wires U (Red), V (White) and W (Black) of the checker to the terminal of disconnected wires (U, V, W) from compressor respectively.

(ii) Operation for judgment.

- 1) Power ON and start check operation on cooling or heating mode.
- 2) Check ON/OFF status of 6 LED's on the checker.
- 3) Judge the PCB by ON/OFF status of 6 LED's on the checker.

ON/OFF status of LED	If all of LED are ON/OFF according to following pattern	If all of LED stay OFF or some of LED are ON/OFF
Control PCB	Normal	Anomalous

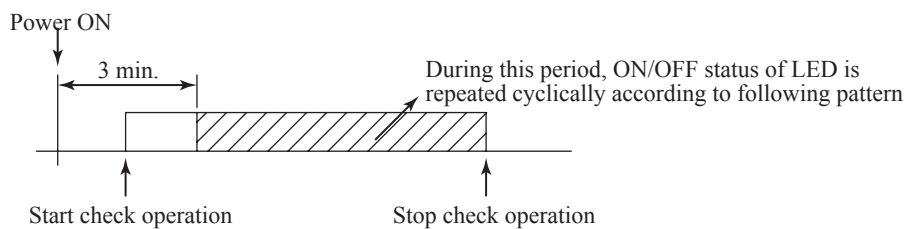

- 4) Stop check operation within about 2minutes after starting check operation.

(b) Models FDC71-250

(i) Setup procedure of checker.

- 1) Power OFF (Turn off the breaker).
- 2) Remove the terminal cover of compressor and disconnect the wires (U, V, W) from compressor.
- 3) Connect the wires U (Red), V (White) and W (Black) of checker to the terminal of disconnected wires (U, V, W) from compressor respectively.

(ii) Operation for judgment.

- 1) Power ON after JSW10-4 on outdoor inverter PCB was turned ON.
- 2) After 15 seconds since power has turned ON, LED start ON/OFF for 5 seconds cyclically and it repeats 10 times.
- 3) Check ON/OFF status of 6 LED's on the checker.
- 4) Judge the PCB by ON/OFF status of 6 LED's on the checker.

ON/OFF status of LED	If all of LED are ON/OFF according to following pattern	If all of LED stay OFF or some of LED are ON/OFF
Inverter PCB	Normal	Anomalous

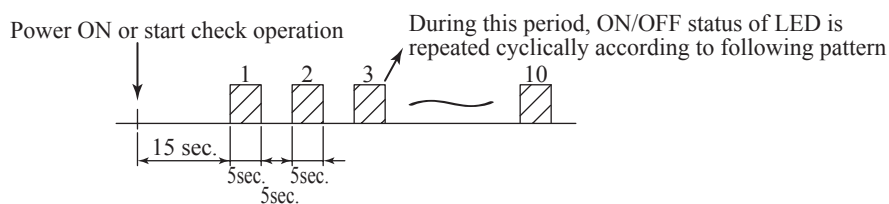

- 5) Be sure to turn off JSW10-4 on outdoor inverter PCB, after finishing the check operation.

**<Inverter checker>**

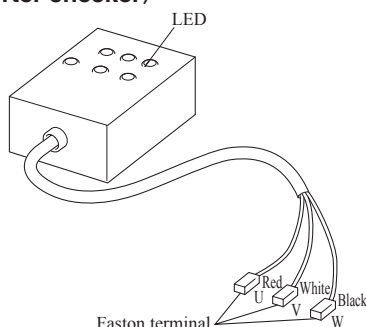

**LED ON/OFF pattern**

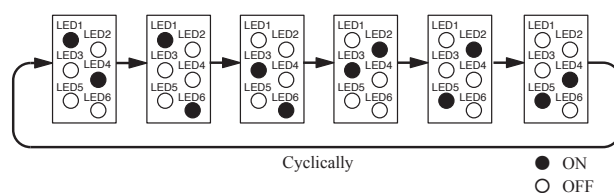

Connect to the terminal of the wires which are disconnected from compressor.

(c) Models FDC71VNP, 90VNP1

(i) Setup procedure of checker.

- 1) Power OFF (Turn off the breaker).
- 2) Remove the terminal cover of compressor and disconnect the wires (U, V, W) from compressor.
- 3) Connect the wires U (Red), V (White) and W (Black) of checker to the terminal of disconnected wires (U, V, W) from compressor respectively.
- 4) Connect the short connector to CNROM on the main PCB.

(ii) Operation for judgment.

- 1) Power ON.
- 2) After 15 seconds since power has turned ON. LED start ON/OFF for 5 seconds cyclically and it repeats 10 times.
- 3) Check ON/OFF status of 6 LED's on the checker.
- 4) Judge the PCB by ON/OFF status of 6 LED's on the checker.

ON/OFF status of LED	If all of LED are ON/OFF according to following pattern	If all of LED stay OFF or some of LED are ON/OFF
Control PCB	Normal	Anomalous

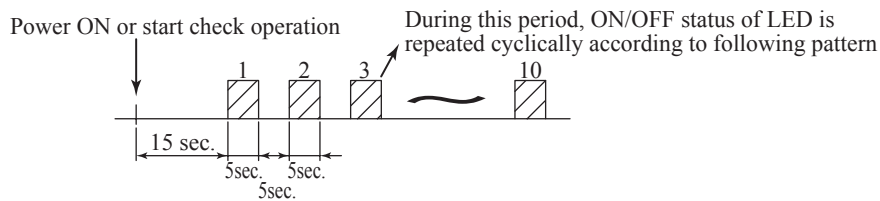

- 5) Be sure to disconnect the connector from CNROM, after finishing the check operation.

<Inverter Checker>

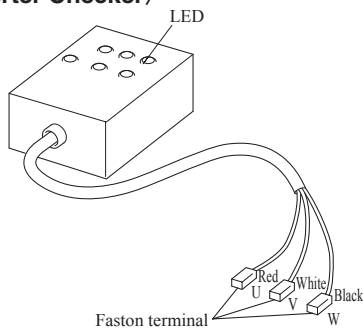

LED ON/OFF pattern

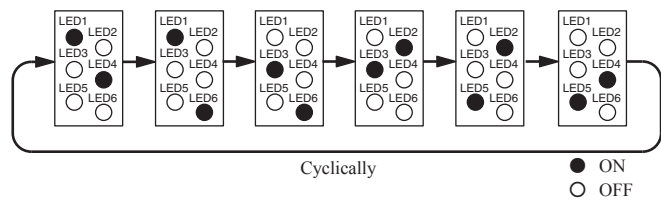

Connect to the terminal of the wires which are disconnected from compressor.

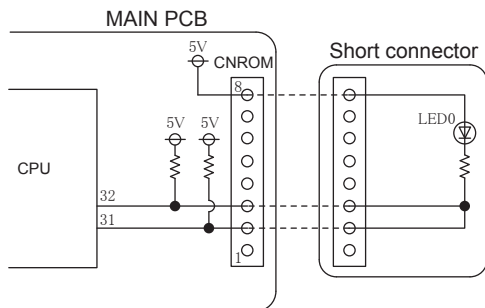



**(8) Outdoor unit control failure diagnosis circuit diagram**  
**Model FDC71VNX**

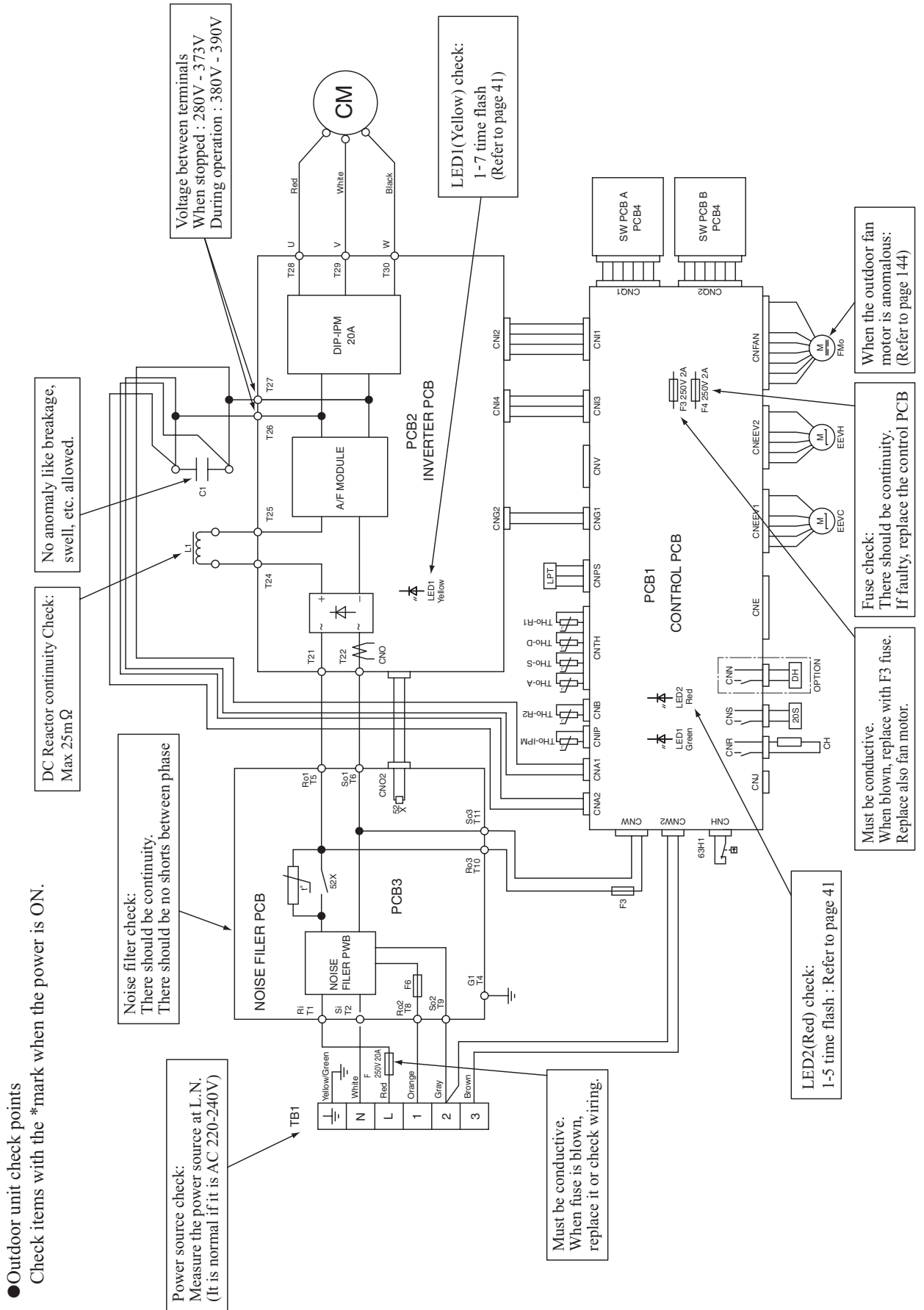

Models FDC100VNX, 125VNX, 140VNX

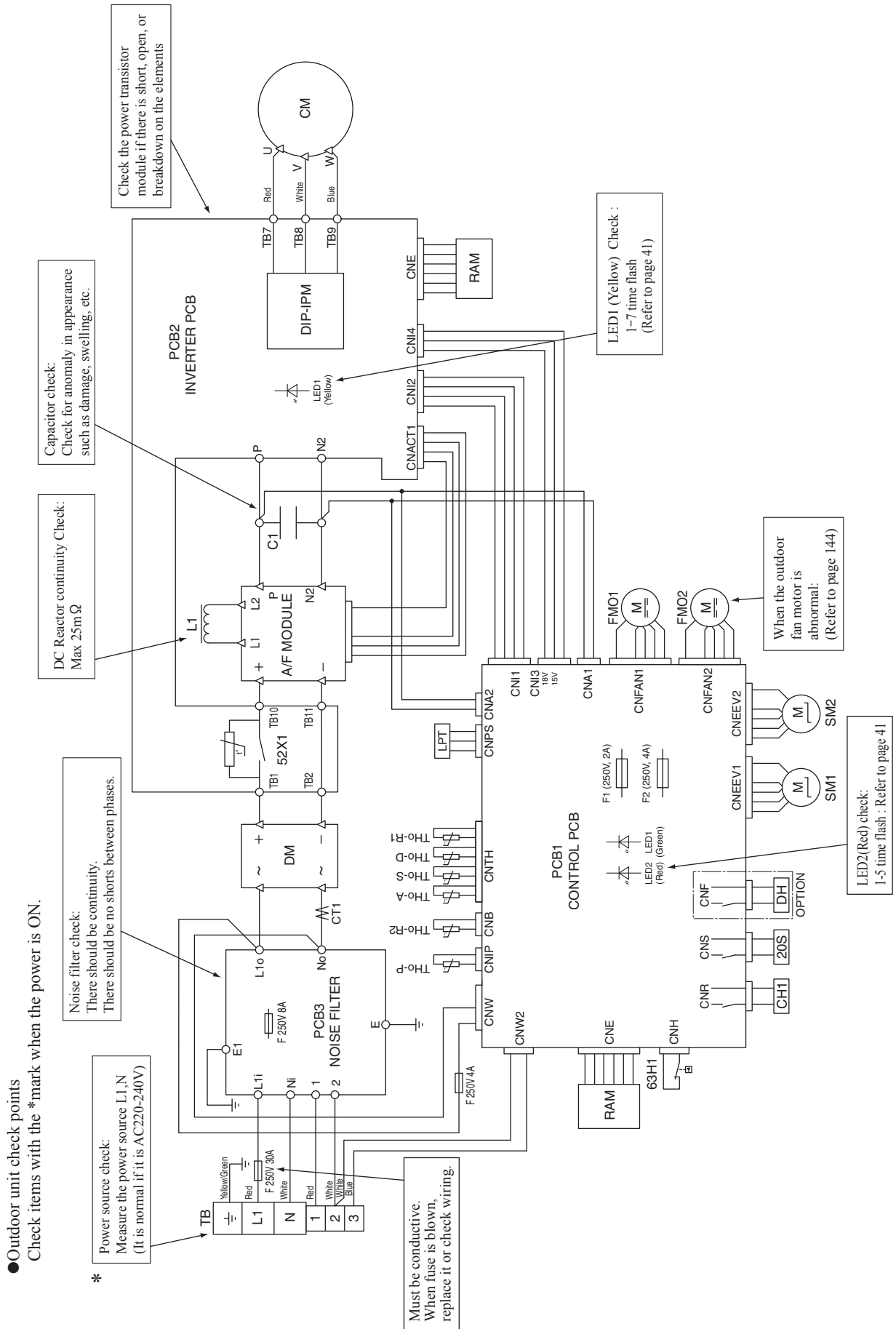

Models FDC100VSX, 125VSX, 140VSX

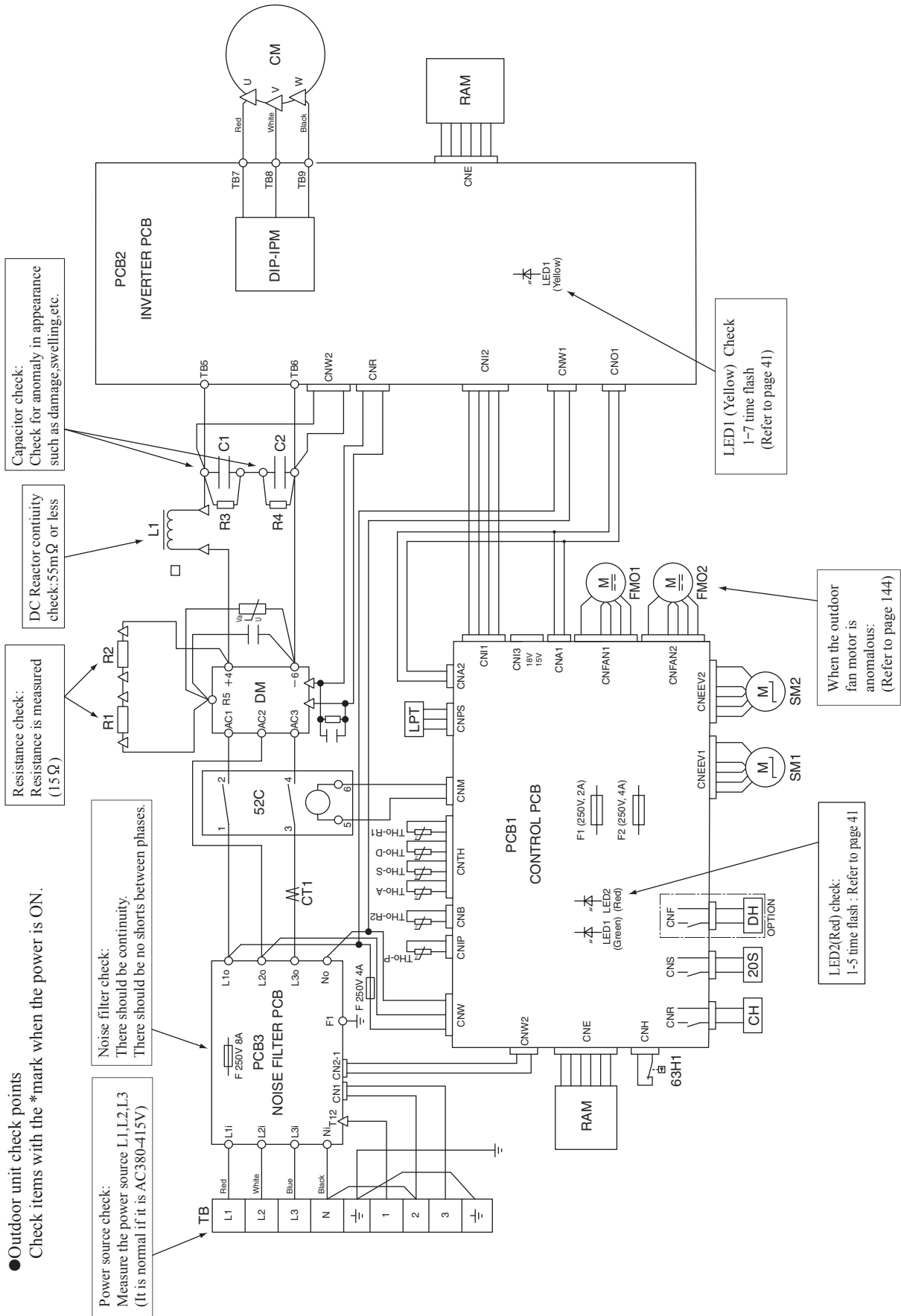

\*

Models FDC100, 125, 140VNA

● Outdoor unit check points

Check items with the \*mark when the power is ON.

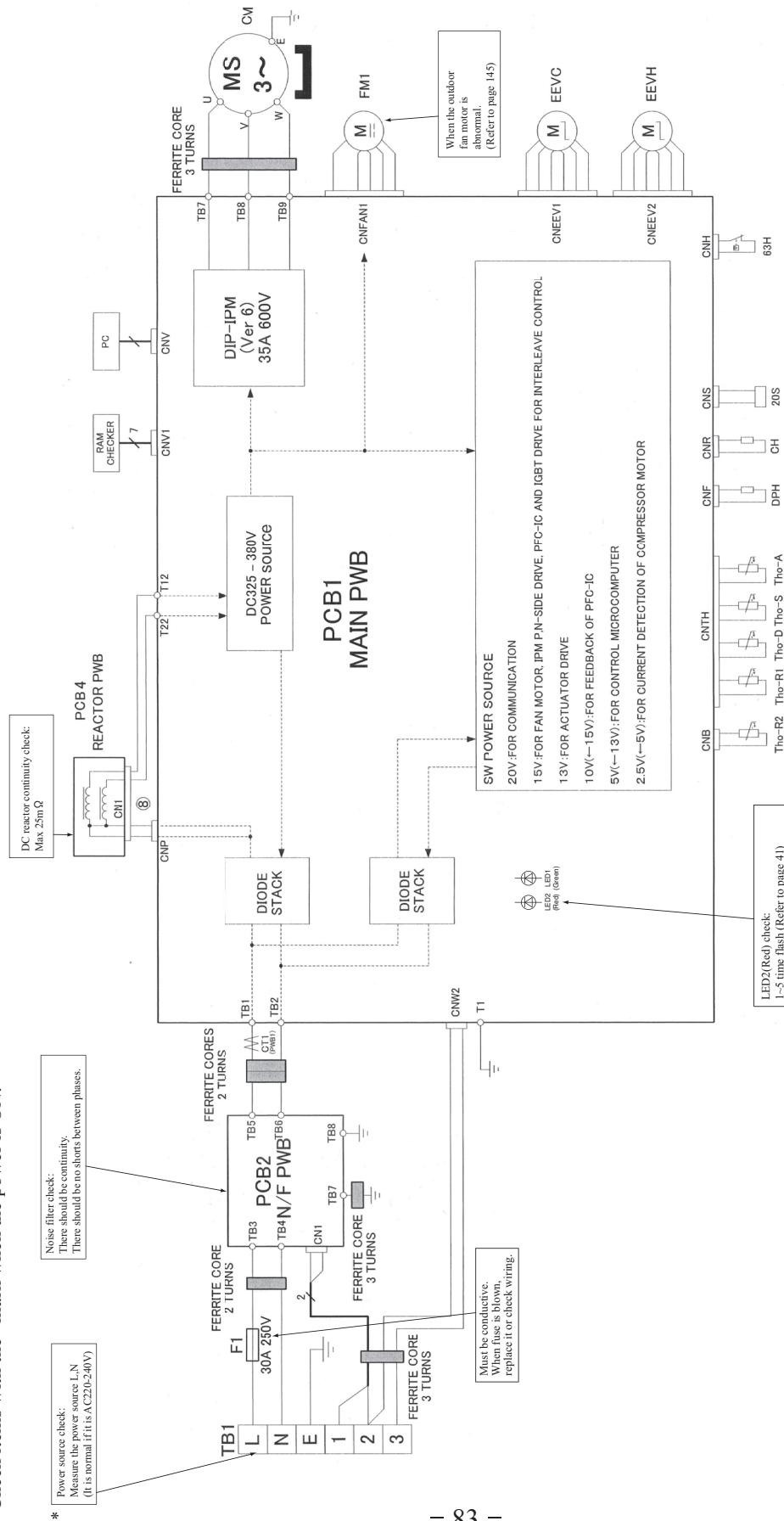

FDC100,125,140VSA

● Outdoor unit check points

Check items with the \*mark when the power is ON.

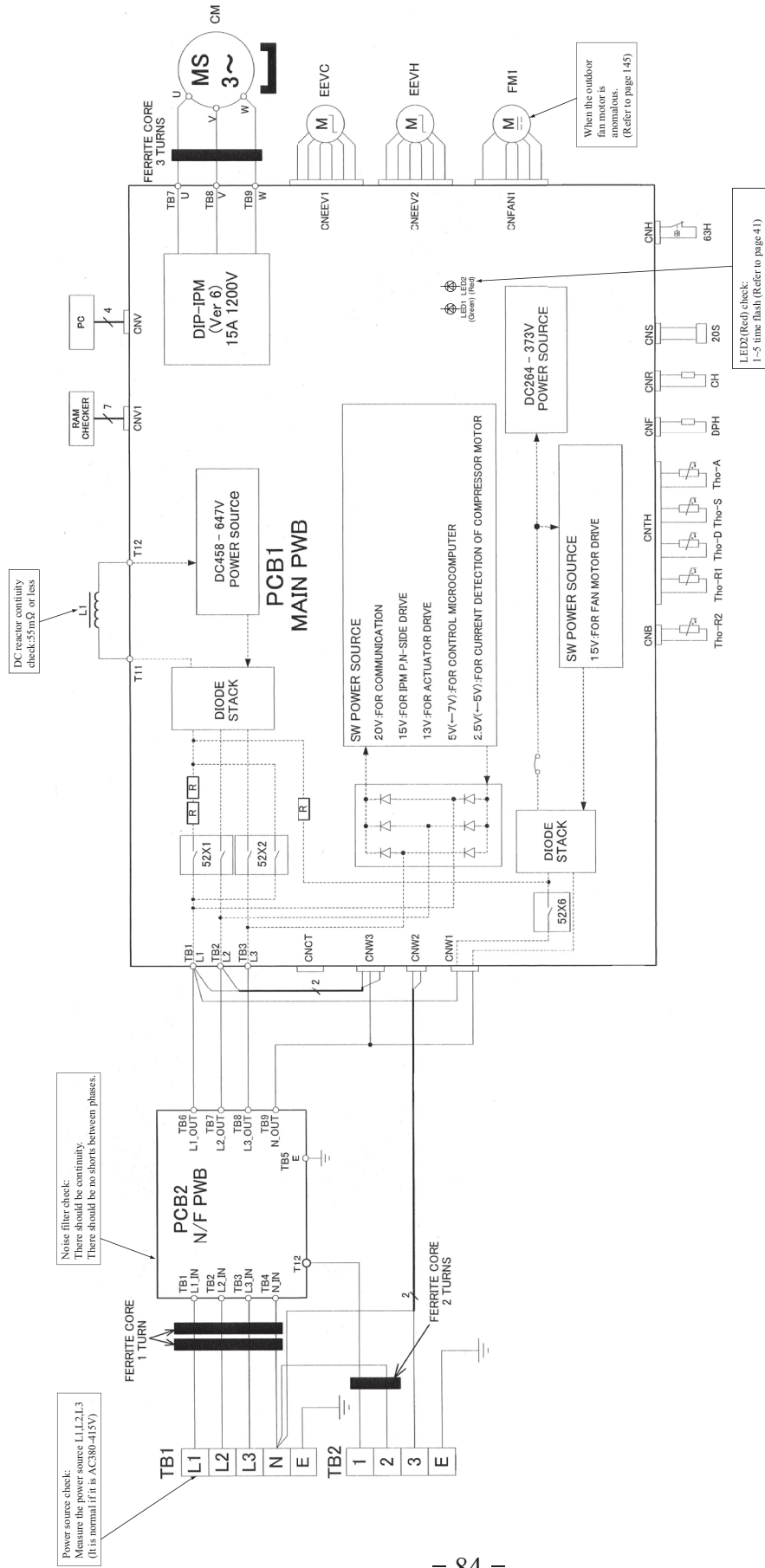

Model FDC200VSA

● Outdoor unitcheck points

Check items with the \*mark when the power is ON.

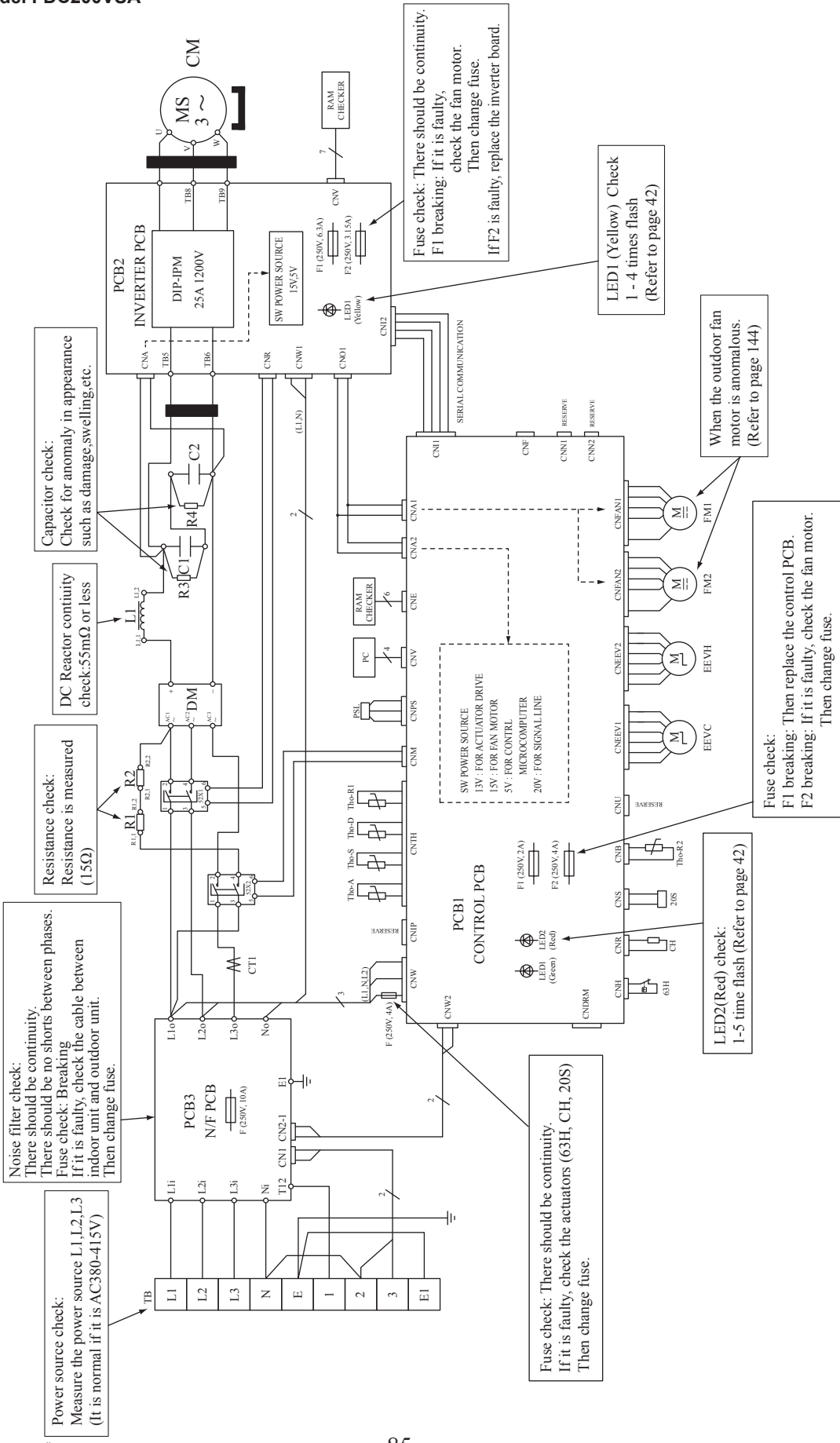

Model FDC250VSA

●Outdoor unit check points

Check items with the \*mark when the power is ON.

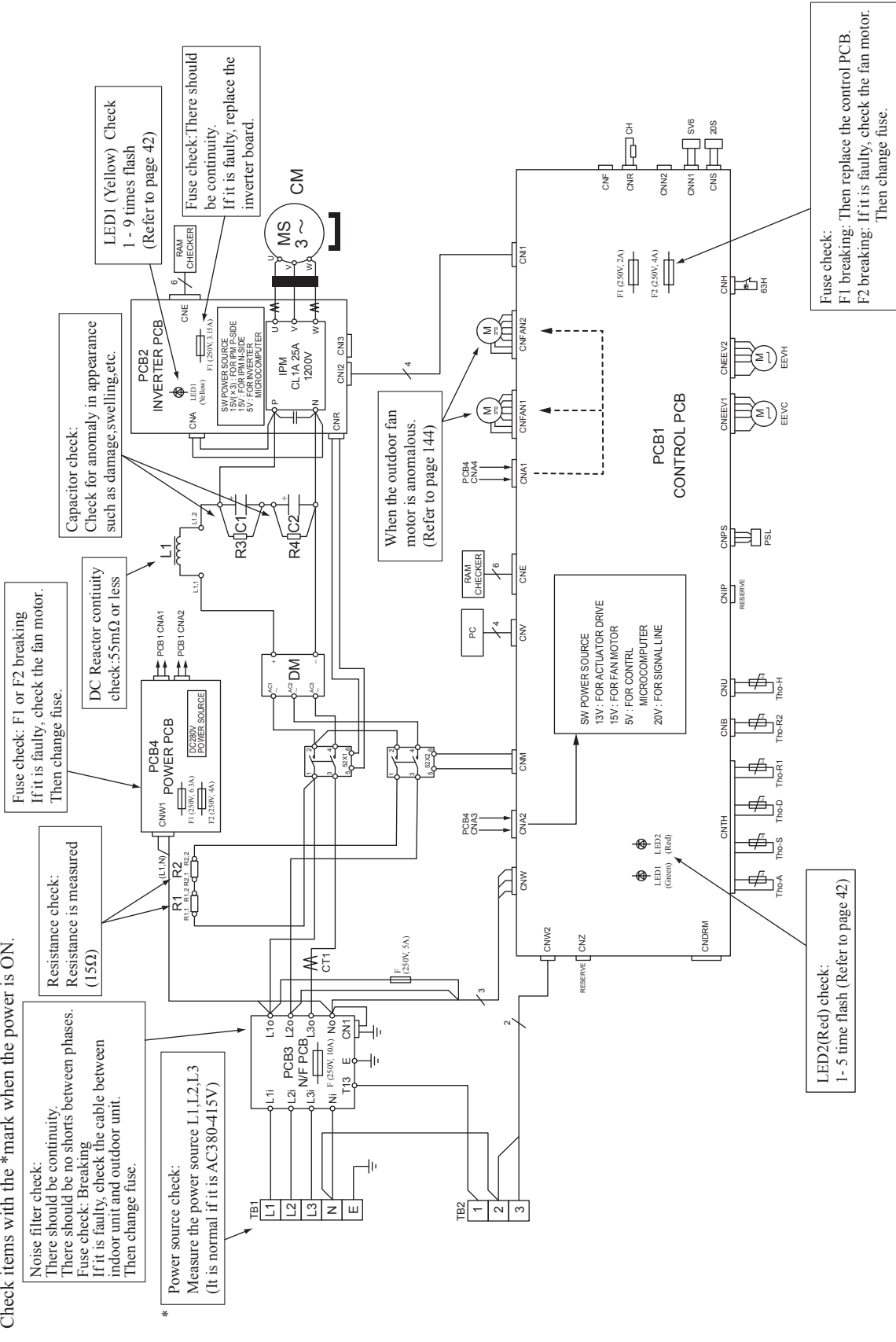

Model FDC71VNP

● Check point of outdoor unit

**⚠ CAUTION- HIGH VOLTAGE**

High voltage is produced in the control box. Don't touch electrical parts in the control box for 5 minutes after the unit is stopped.

Color symbol

BK	Black
BL	Blue
RD	Red
WH	White
YE	Yellow
YG	Yellow / Green

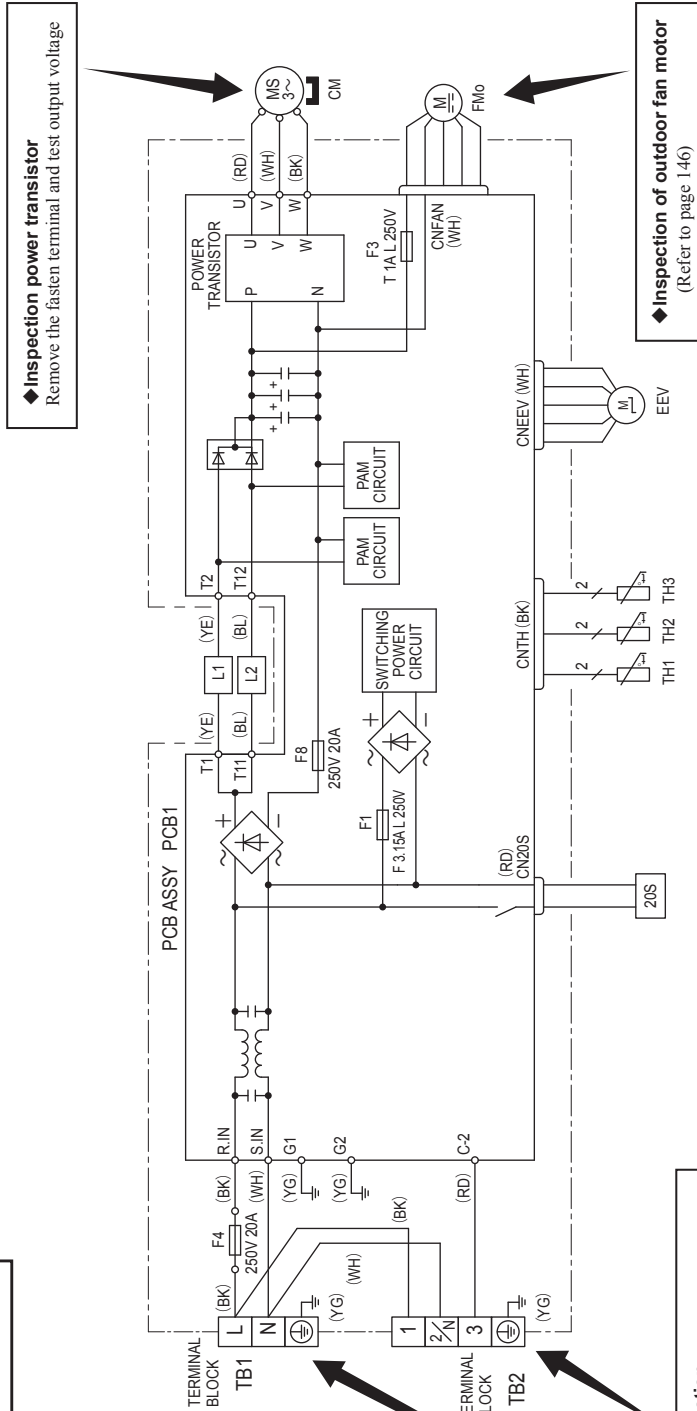

◆ Inspection power transistor  
Remove the fasten terminal and test output voltage

◆ Inspection of outdoor fan motor  
(Refer to page 146)

◆ Power source and serial signal inspection

- ① to ③: AC 220/230/240V
- ① to ②(N): AC220/230/240V
- ②(N) to ③: Normal if the voltage oscillates between DC 0 and approx. 20V



Model FDC90VNP1

● Check point of outdoor unit

**⚠ CAUTION- HIGH VOLTAGE**  
 High voltage is produced in the control box. Don't touch electrical parts in the control box for 5 minutes after the units stopped.

Color symbol	
BK	Black
BL	Blue
RD	Red
WH	White
YE	Yellow
YG	Yellow / Green

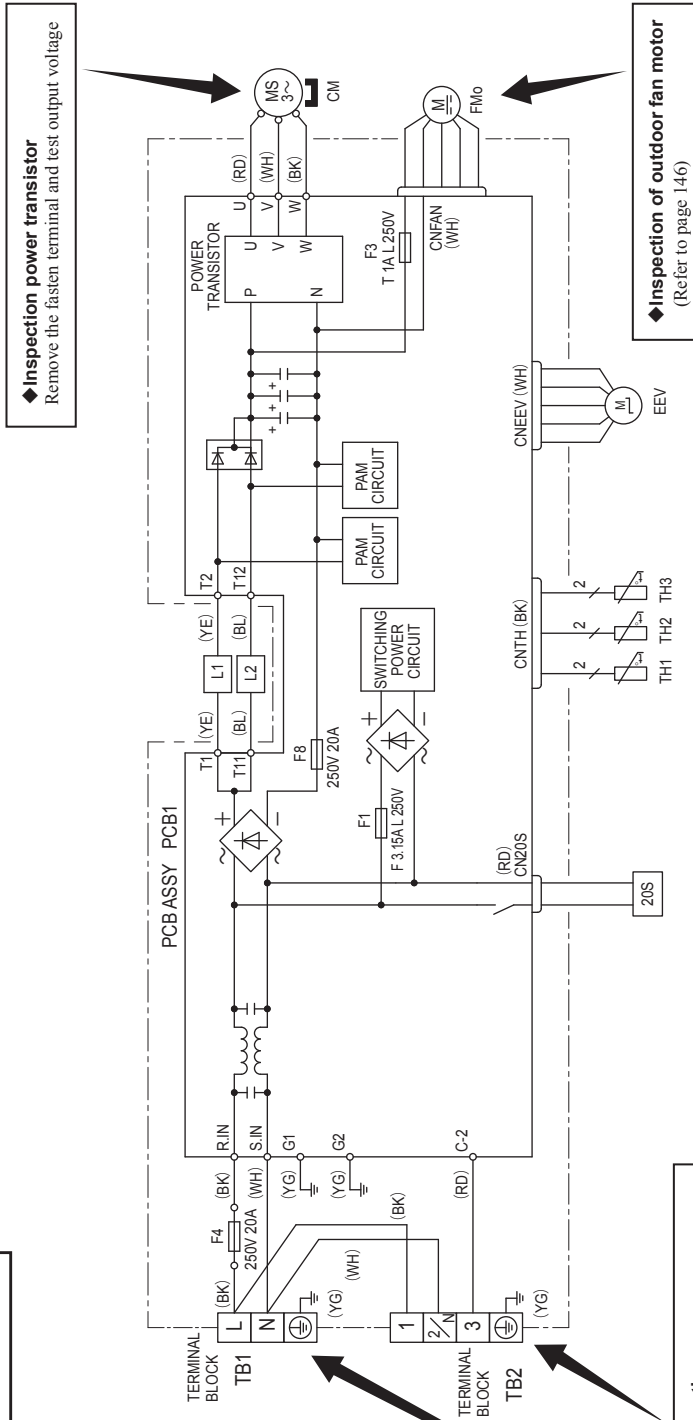

◆ Inspection power transistor  
 Remove the fasten terminal and test output voltage

◆ Inspection of outdoor fan motor  
 (Refer to page 146)

◆ Power source and serial signal inspection  
 ① to ③: AC 220/230/240V  
 ① to ②(N): AC220/230/240V  
 ②(N) to ③: Normal if the voltage oscillates between DC 0 and approx. 20V

**Model FDC100VNP**

● **Check point of outdoor unit**

**⚠ CAUTION – HIGH VOLTAGE**

High voltage is produced in the control box. Don't touch electrical parts in the control box for 5 minutes after the unit is stopped.

**Color symbol**

Mark	Color
BK	Black
BL	Blue
RD	Red
WH	White
YE	Yellow
Y/G	Yellow/Green

◆ **Voltage check in PCB**

The normal range is as follows.

Display	Voltage range
① DC280V	DC230V - DC310V
② DC 20V	DC 18V - DC 22V
③ DC 13V	DC 12V - DC 14V
④ DC 15V	DC 14V - DC 16V
⑤ DC 5V	DC 4V - DC 6V
⑥ DC 2.5V	DC 2.3V - DC 2.5V

◆ **Inspection power transistor**

Remove the faston terminal and test output voltage.

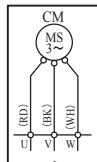

◆ **Power source and serial signal inspection**

- ① to ② : AC220/230/240V
- ① to ②/N : AC220/230/240V
- ②/N to ③ : Normal if the voltage oscillates between DC 0 and approx. 20V

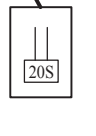
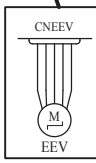
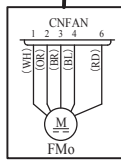
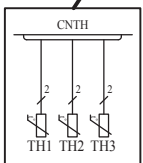
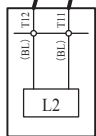
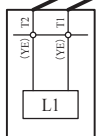
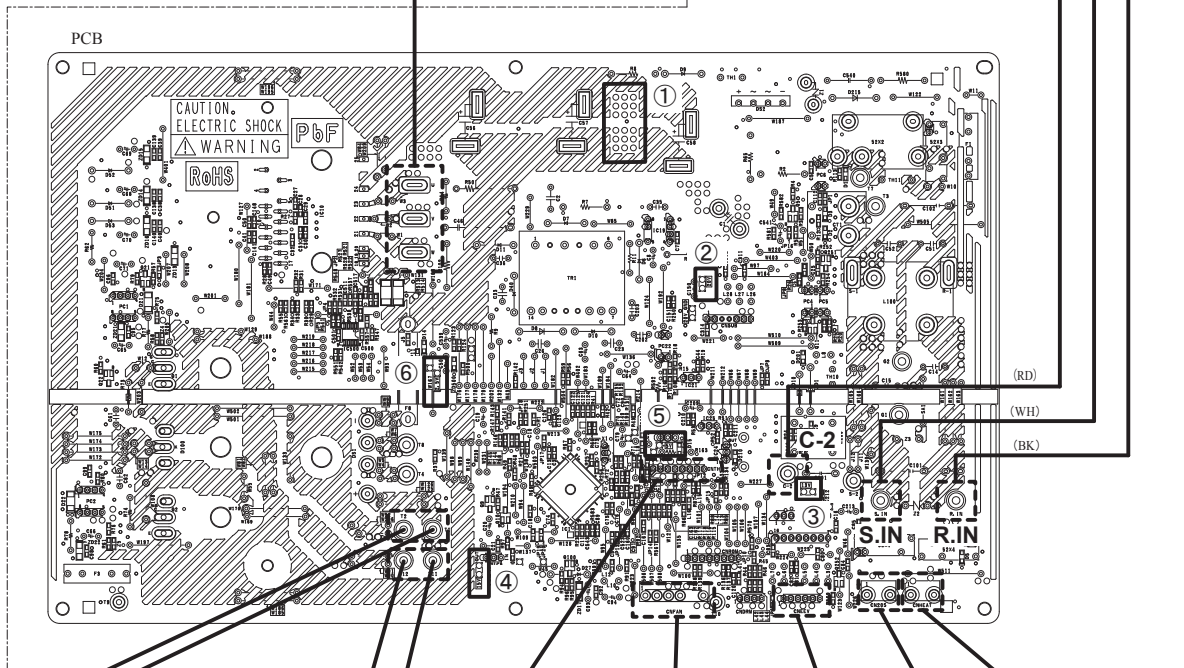
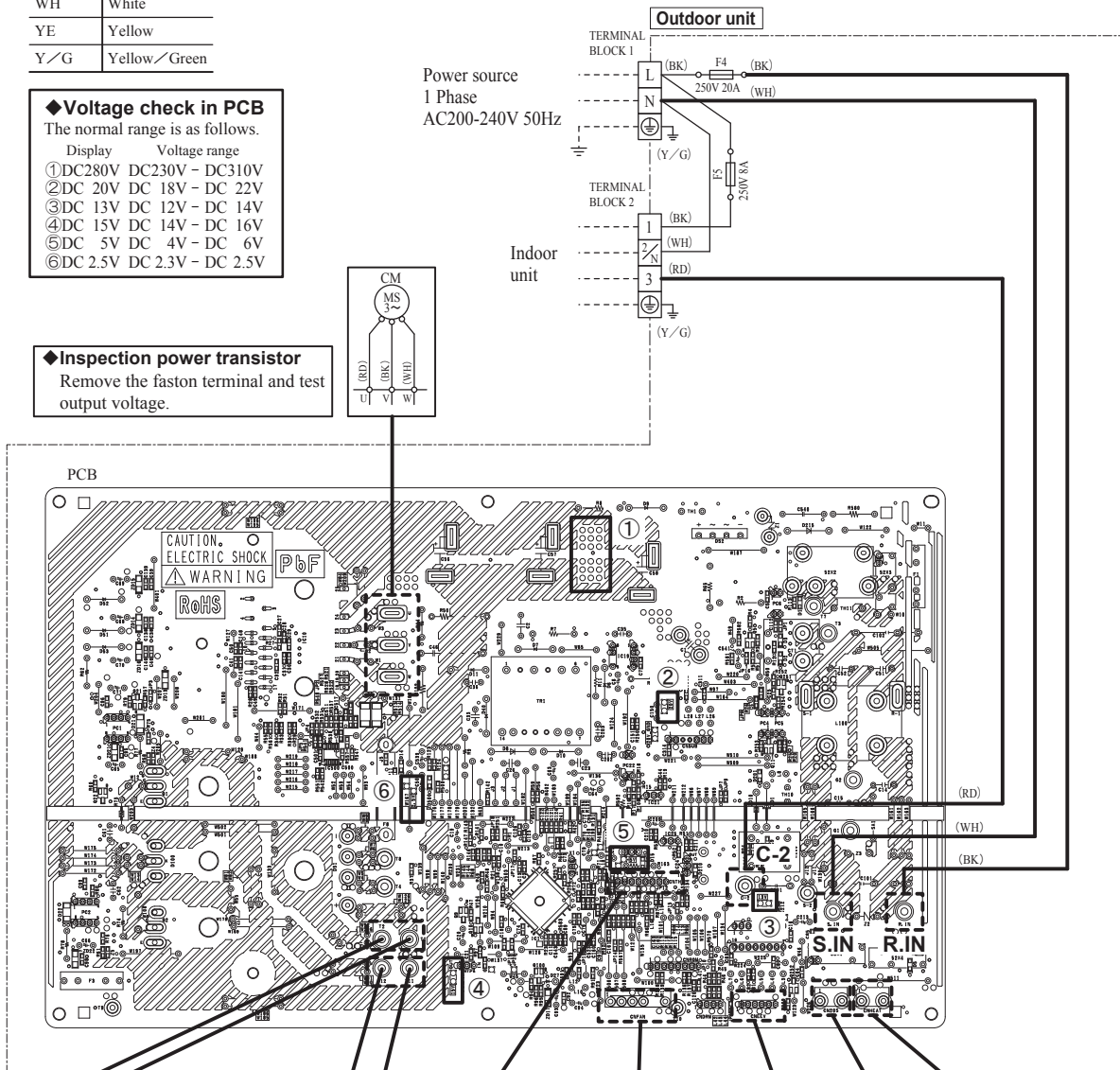

◆ **Inspection of resistance value of sensor**  
Remove the connector and check the resistance value.



◆ **Inspection of outdoor fan motor**  
(Refer to page 146)

## 1.2.2 Troubleshooting flow

### (1) List of troubles

Models FDC71, 100, 125, 140VNX, 100, 125, 140VSX



FDC100, 125, 140VNA, 100, 125, 140VSA

Remote control display	Description of trouble	Reference page
None	Operates but does not cool	93
None	Operates but does not heat	94
None	Earth leakage breaker activated	95
None	Excessive noise/vibration (1/3)	96
None	Excessive noise/vibration (2/3)	97
None	Excessive noise/vibration (3/3)	98
None	Louver motor failure	99
None	Power source system error (Power source to indoor unit control PCB)	100
None	Power source system error (Power source to remote control)	101
INSPECT I/U	INSPECT I/U (When 1 or 2 remote controls are connected)	102
INSPECT I/U	INSPECT I/U (Connection of 3 units or more remote controls)	103
 WAIT 	Communication error at initial operation (Models FDC71-140 only)	104-106
None	No display	112
E1	Remote control communication circuit error	113
E5	Communication error during operation	114
E6	Indoor heat exchanger temperature sensor anomaly	115
E7	Return air temperature sensor anomaly	116
E8	Heating overload operation	117
E9	Drain trouble	118
E10	Excessive number of connected indoor units (more than 17 units) by controlling with one remote control	119
E11	Address setting error of indoor units	120
E14	Communication error between master and slave indoor units	121
E16	Indoor fan motor anomaly	122
E18	Address setting error of master and slave indoor units	123
E19	Indoor unit operation check, drain pump motor check setting error	124
E20	Indoor fan motor rotation speed anomaly	125
E21	Defective panel switch operation	126
E28	Remote control temperature sensor anomaly	127
E35	Cooling overload operation (Models FDC71-140 only)	128
E36	Discharge pipe temperature error	130
E37	Outdoor heat exchanger temperature sensor anomaly	131
E38	Outdoor air temperature sensor anomaly	132
E39	Discharge pipe temperature sensor anomaly	133
E40	High pressure error (63H1 activated) (Models FDC71-140 only)	134
E41	Power transistor overheat (Models FDC71-140VNX, 100-140VSX only)	136
E42	Current cut	138 · 139
E45	Communication error between inverter PCB and outdoor unit control PCB (Models FDC71-140VNX, 100-140VSX only)	140
E47	Inverter PCB A/F module anomaly (Model FDC71VNX only)	141
E47	Control PCB A/F module anomaly (Models FDC100-140VNA only)	142
E48	Outdoor fan motor anomaly (Models FDC71-140VNX, 100-140VSX only)	144
E48	Outdoor fan motor anomaly (Models FDC100-140VNA / VSA only)	145
E49	Low pressure error or low pressure sensor anomaly (Models FDC71-140VNX, 100-140VSX only)	147 · 148
E51	Inverter and fan motor anomaly (Models FDC71-140 only)	149
E53	Suction pipe temperature sensor anomaly (Models FDC71-140 only)	152
E54	Low pressure sensor anomaly (Models FDC71-140VNX, 100-140VSX only)	153
E57	Insufficient refrigerant amount or detection of service valve closure (Models FDC71-140 only)	155
E59	Compressor startup failure (Models FDC71-140VNX, 100-140VSX only)	158 · 159
E59	Compressor startup failure (Models FDC100-140VNA / VSA only)	160 · 161

**Models FDC200, 250VSA**

Remote control display	Description of trouble	Reference page
None	Operates but does not cool	93
None	Operates but does not heat	94
None	Earth leakage breaker activated	95
None	Excessive noise/vibration (1/3)	96
None	Excessive noise/vibration (2/3)	97
None	Excessive noise/vibration (3/3)	98
None	Louver motor failure	99
None	Power source system error (Power source to indoor unit control PCB)	100
None	Power source system error (Power source to remote control)	101
INSPECT I/U	INSPECT I/U (When 1 or 2 remote controls are connected)	102
INSPECT I/U	INSPECT I/U (Connection of 3 units or more remote controls)	103
🔊WAIT🔊	Communication error at initial operation	107 · 108
None	No display	112
E1	Remote control communication circuit error	113
E5	Communication error during operation	114
E6	Indoor heat exchanger temperature sensor anomaly	115
E7	Return air temperature sensor anomaly	116
E8	Heating overload operation	117
E9	Drain trouble	118
E10	Excessive number of connected indoor units (more than 17 units) by controlling with one remote control	119
E11	Address setting error of indoor units	120
E14	Communication error between master and slave indoor units	121
E16	Indoor fan motor anomaly	122
E18	Address setting error of master and slave indoor units	123
E19	Indoor unit operation check, drain pump motor check setting error	124
E20	Indoor fan motor rotation speed anomaly	125
E21	Defective panel switch operation	126
E28	Remote control temperature sensor anomaly	127
E35	Cooling overload operation	128
E36	Discharge pipe temperature error	130
E37	Outdoor heat exchanger temperature sensor anomaly	131
E38	Outdoor air temperature sensor anomaly	132
E39	Discharge pipe temperature sensor anomaly	133
E40	High pressure error (63H1 activated)	134
E41	Power transistor overheat	137
E42	Current cut	138 · 139
E45	Communication error between inverter PCB and outdoor unit control PCB	140
E48	Outdoor fan motor anomaly	144
E49	Low pressure error or low pressure sensor anomaly	147 · 148
E51	Inverter or power transistor anomaly	150
E53	Suction pipe temperature sensor anomaly	152
E54	Low pressure sensor anomaly	153
E55	Compressor under dome temperature sensor anomaly (Model FDC250VSA only)	154
E57	Insufficient refrigerant amount or detection of service valve closure	155
E59	Compressor startup failure	162 · 163

**Models FDC71, 90, 100VNP**

Remote control display	Description of trouble	Reference page
None	Operates but does not cool	92
None	Operates but does not heat	93
None	Earth leakage breaker activated	94
None	Excessive noise/vibration (1/3)	95
None	Excessive noise/vibration (2/3)	96
None	Excessive noise/vibration (3/3)	97
None	Louver motor failure	98
None	Power source system error (Power source to indoor unit control PCB)	99
None	Power source system error (Power source to remote control)	100
INSPECT I/U	INSPECT I/U (When 1 or 2 remote controls are connected)	101
INSPECT I/U	INSPECT I/U (Connection of 3 units or more remote controls)	102
 WAIT 	Communication error at initial operation	108-110
E1	Remote control communication circuit error	112
E5	Communication error during operation	113
E6	Indoor heat exchanger temperature sensor anomaly	114
E7	Return air temperature sensor anomaly	115
E8	Heating overload operation	116
E9	Drain trouble	117
E10	Excessive number of connected indoor units (more than 17 units) by controlling with one remote control	118
E11	Address setting error of indoor units	119
E14	Communication error between master and slave indoor units	120
E16	Indoor fan motor anomaly	121
E18	Address setting error of master and slave indoor units	122
E19	Indoor unit operation check, drain pump motor check setting error	123
E20	Indoor fan motor rotation speed anomaly	124
E21	Defective panel switch operation	125
E28	Remote control temperature sensor anomaly	126
E35	Cooling overload operation	128
E36	Discharge pipe temperature error	129
E37	Outdoor heat exchanger temperature sensor anomaly	130
E38	Outdoor air temperature sensor anomaly	131
E39	Discharge pipe temperature sensor anomaly	132
E40	Service valve (gas side) closing operation (Models FDC71, 90VNP only)	134
E42	Current cut	137 · 138
E47	Active filter voltage error	142
E48	Outdoor fan motor anomaly	145
E51	Power transistor anomaly	150
E57	Insufficient refrigerant amount or detection of service valve closure	155
E58	Current safe stop	156
E59	Compressor startup failure	163
E60	Compressor rotor lock error	164

(2) Troubleshooting

Error code Remote control: None	LED	Green	Red	Content <b>Operates but does not cool</b>
	Indoor	Keeps flashing	Stays OFF	
	Outdoor	Keeps flashing	Stays OFF	

1. Applicable model
All models
2. Error detection method
3. Condition of error displayed
4. Presumable cause
<ul style="list-style-type: none"> <li>Poor compression of compressor</li> <li>Faulty expansion valve operation</li> </ul>

5. Troubleshooting				
<table border="1"> <thead> <tr> <th>Diagnosis</th> <th>Countermeasure</th> </tr> </thead> <tbody> <tr> <td> <p>Check the indoor fan operation. Check the temperature difference between return and supply air.</p> <pre> graph TD     Start[Check indoor fan operation and temperature difference] --&gt; D1{Is the temperature difference between return and supply air 10-20°C at cooling?}     D1 -- YES --&gt; D2{Does the heat load increase after installation?}     D1 -- NO --&gt; D3{Is the compressor operating?}     D2 -- YES --&gt; Box1[Mistake in model selection. Calculate heat load once more.]     D2 -- NO --&gt; CM1[It is normal. (This unit is designed to start in the soft start mode by detecting the under dome temperature of compressor when it restart after power reset.)]     D3 -- NO --&gt; D4{"⌚ WAIT ⌚" message is displayed (for 3 seconds) when performing cooling, defrosting and heating operations from the remote control.}     D3 -- YES --&gt; D5{Is the compressor rotation speed low?}     D4 -- YES --&gt; CM2[It is necessary to replace to higher capacity one or to install additional unit.]     D4 -- NO --&gt; CM3[Compressor may be stopped by the error detection control. For the contents of control, refer to anomalous stop control by controlling compressor rotation speed of microcomputer control functions.]     D5 -- NO --&gt; CM4[Inspect the followings.     &lt;ul&gt;     &lt;li&gt;Minor clogging of filter&lt;/li&gt;     &lt;li&gt;Minor clogging of heat exchanger&lt;/li&gt;     &lt;li&gt;Minor short-circuit&lt;/li&gt;     &lt;li&gt;Minor shortage of refrigerant amount&lt;/li&gt;     &lt;li&gt;Poor compression of compressor&lt;/li&gt;     &lt;/ul&gt;]     D5 -- YES --&gt; Box2[Check which control "Determination control of compressor rotation speed" or "Protective control by controlling compressor rotation speed" is appropriate to this phenomenon.]     Box2 --&gt; D6{Are the temperature conditions of room and outdoor air close to the rated conditions? (1)}     D6 -- YES --&gt; CM5[Considering appropriate operation control, check suspicious points. Inspect the followings for reference.     &lt;ul&gt;     &lt;li&gt;Major clogging of filter&lt;/li&gt;     &lt;li&gt;Major clogging of heat exchanger&lt;/li&gt;     &lt;li&gt;Major short-circuit&lt;/li&gt;     &lt;li&gt;Major shortage of refrigerant amount&lt;/li&gt;     &lt;li&gt;Compressor protection ON&lt;/li&gt;     &lt;li&gt;Indoor fan tap&lt;/li&gt;     &lt;li&gt;Valid setting of silent mode&lt;/li&gt;     &lt;/ul&gt;]     D6 -- NO --&gt; End[The unit is operating normally but is operating under the control for protecting compressor or other respective parts.]                     </pre> </td> <td> <p>It is normal. (This unit is designed to start in the soft start mode by detecting the under dome temperature of compressor when it restart after power reset.)</p> <p>It is necessary to replace to higher capacity one or to install additional unit.</p> <p>Compressor refrigerant oil protection control at starting is activated. For the contents of control, refer to the compressor start control of the microcomputer control functions.</p> <p>Compressor may be stopped by the error detection control. For the contents of control, refer to anomalous stop control by controlling compressor rotation speed of microcomputer control functions.</p> <p>Inspect the followings.</p> <ul style="list-style-type: none"> <li>Minor clogging of filter</li> <li>Minor clogging of heat exchanger</li> <li>Minor short-circuit</li> <li>Minor shortage of refrigerant amount</li> <li>Poor compression of compressor</li> </ul> <p>Considering appropriate operation control, check suspicious points. Inspect the followings for reference.</p> <ul style="list-style-type: none"> <li>Major clogging of filter</li> <li>Major clogging of heat exchanger</li> <li>Major short-circuit</li> <li>Major shortage of refrigerant amount</li> <li>Compressor protection ON</li> <li>Indoor fan tap</li> <li>Valid setting of silent mode</li> </ul> </td> </tr> </tbody> </table>	Diagnosis	Countermeasure	<p>Check the indoor fan operation. Check the temperature difference between return and supply air.</p> <pre> graph TD     Start[Check indoor fan operation and temperature difference] --&gt; D1{Is the temperature difference between return and supply air 10-20°C at cooling?}     D1 -- YES --&gt; D2{Does the heat load increase after installation?}     D1 -- NO --&gt; D3{Is the compressor operating?}     D2 -- YES --&gt; Box1[Mistake in model selection. Calculate heat load once more.]     D2 -- NO --&gt; CM1[It is normal. (This unit is designed to start in the soft start mode by detecting the under dome temperature of compressor when it restart after power reset.)]     D3 -- NO --&gt; D4{"⌚ WAIT ⌚" message is displayed (for 3 seconds) when performing cooling, defrosting and heating operations from the remote control.}     D3 -- YES --&gt; D5{Is the compressor rotation speed low?}     D4 -- YES --&gt; CM2[It is necessary to replace to higher capacity one or to install additional unit.]     D4 -- NO --&gt; CM3[Compressor may be stopped by the error detection control. For the contents of control, refer to anomalous stop control by controlling compressor rotation speed of microcomputer control functions.]     D5 -- NO --&gt; CM4[Inspect the followings.     &lt;ul&gt;     &lt;li&gt;Minor clogging of filter&lt;/li&gt;     &lt;li&gt;Minor clogging of heat exchanger&lt;/li&gt;     &lt;li&gt;Minor short-circuit&lt;/li&gt;     &lt;li&gt;Minor shortage of refrigerant amount&lt;/li&gt;     &lt;li&gt;Poor compression of compressor&lt;/li&gt;     &lt;/ul&gt;]     D5 -- YES --&gt; Box2[Check which control "Determination control of compressor rotation speed" or "Protective control by controlling compressor rotation speed" is appropriate to this phenomenon.]     Box2 --&gt; D6{Are the temperature conditions of room and outdoor air close to the rated conditions? (1)}     D6 -- YES --&gt; CM5[Considering appropriate operation control, check suspicious points. Inspect the followings for reference.     &lt;ul&gt;     &lt;li&gt;Major clogging of filter&lt;/li&gt;     &lt;li&gt;Major clogging of heat exchanger&lt;/li&gt;     &lt;li&gt;Major short-circuit&lt;/li&gt;     &lt;li&gt;Major shortage of refrigerant amount&lt;/li&gt;     &lt;li&gt;Compressor protection ON&lt;/li&gt;     &lt;li&gt;Indoor fan tap&lt;/li&gt;     &lt;li&gt;Valid setting of silent mode&lt;/li&gt;     &lt;/ul&gt;]     D6 -- NO --&gt; End[The unit is operating normally but is operating under the control for protecting compressor or other respective parts.]                     </pre>	<p>It is normal. (This unit is designed to start in the soft start mode by detecting the under dome temperature of compressor when it restart after power reset.)</p> <p>It is necessary to replace to higher capacity one or to install additional unit.</p> <p>Compressor refrigerant oil protection control at starting is activated. For the contents of control, refer to the compressor start control of the microcomputer control functions.</p> <p>Compressor may be stopped by the error detection control. For the contents of control, refer to anomalous stop control by controlling compressor rotation speed of microcomputer control functions.</p> <p>Inspect the followings.</p> <ul style="list-style-type: none"> <li>Minor clogging of filter</li> <li>Minor clogging of heat exchanger</li> <li>Minor short-circuit</li> <li>Minor shortage of refrigerant amount</li> <li>Poor compression of compressor</li> </ul> <p>Considering appropriate operation control, check suspicious points. Inspect the followings for reference.</p> <ul style="list-style-type: none"> <li>Major clogging of filter</li> <li>Major clogging of heat exchanger</li> <li>Major short-circuit</li> <li>Major shortage of refrigerant amount</li> <li>Compressor protection ON</li> <li>Indoor fan tap</li> <li>Valid setting of silent mode</li> </ul>
Diagnosis	Countermeasure			
<p>Check the indoor fan operation. Check the temperature difference between return and supply air.</p> <pre> graph TD     Start[Check indoor fan operation and temperature difference] --&gt; D1{Is the temperature difference between return and supply air 10-20°C at cooling?}     D1 -- YES --&gt; D2{Does the heat load increase after installation?}     D1 -- NO --&gt; D3{Is the compressor operating?}     D2 -- YES --&gt; Box1[Mistake in model selection. Calculate heat load once more.]     D2 -- NO --&gt; CM1[It is normal. (This unit is designed to start in the soft start mode by detecting the under dome temperature of compressor when it restart after power reset.)]     D3 -- NO --&gt; D4{"⌚ WAIT ⌚" message is displayed (for 3 seconds) when performing cooling, defrosting and heating operations from the remote control.}     D3 -- YES --&gt; D5{Is the compressor rotation speed low?}     D4 -- YES --&gt; CM2[It is necessary to replace to higher capacity one or to install additional unit.]     D4 -- NO --&gt; CM3[Compressor may be stopped by the error detection control. For the contents of control, refer to anomalous stop control by controlling compressor rotation speed of microcomputer control functions.]     D5 -- NO --&gt; CM4[Inspect the followings.     &lt;ul&gt;     &lt;li&gt;Minor clogging of filter&lt;/li&gt;     &lt;li&gt;Minor clogging of heat exchanger&lt;/li&gt;     &lt;li&gt;Minor short-circuit&lt;/li&gt;     &lt;li&gt;Minor shortage of refrigerant amount&lt;/li&gt;     &lt;li&gt;Poor compression of compressor&lt;/li&gt;     &lt;/ul&gt;]     D5 -- YES --&gt; Box2[Check which control "Determination control of compressor rotation speed" or "Protective control by controlling compressor rotation speed" is appropriate to this phenomenon.]     Box2 --&gt; D6{Are the temperature conditions of room and outdoor air close to the rated conditions? (1)}     D6 -- YES --&gt; CM5[Considering appropriate operation control, check suspicious points. Inspect the followings for reference.     &lt;ul&gt;     &lt;li&gt;Major clogging of filter&lt;/li&gt;     &lt;li&gt;Major clogging of heat exchanger&lt;/li&gt;     &lt;li&gt;Major short-circuit&lt;/li&gt;     &lt;li&gt;Major shortage of refrigerant amount&lt;/li&gt;     &lt;li&gt;Compressor protection ON&lt;/li&gt;     &lt;li&gt;Indoor fan tap&lt;/li&gt;     &lt;li&gt;Valid setting of silent mode&lt;/li&gt;     &lt;/ul&gt;]     D6 -- NO --&gt; End[The unit is operating normally but is operating under the control for protecting compressor or other respective parts.]                     </pre>	<p>It is normal. (This unit is designed to start in the soft start mode by detecting the under dome temperature of compressor when it restart after power reset.)</p> <p>It is necessary to replace to higher capacity one or to install additional unit.</p> <p>Compressor refrigerant oil protection control at starting is activated. For the contents of control, refer to the compressor start control of the microcomputer control functions.</p> <p>Compressor may be stopped by the error detection control. For the contents of control, refer to anomalous stop control by controlling compressor rotation speed of microcomputer control functions.</p> <p>Inspect the followings.</p> <ul style="list-style-type: none"> <li>Minor clogging of filter</li> <li>Minor clogging of heat exchanger</li> <li>Minor short-circuit</li> <li>Minor shortage of refrigerant amount</li> <li>Poor compression of compressor</li> </ul> <p>Considering appropriate operation control, check suspicious points. Inspect the followings for reference.</p> <ul style="list-style-type: none"> <li>Major clogging of filter</li> <li>Major clogging of heat exchanger</li> <li>Major short-circuit</li> <li>Major shortage of refrigerant amount</li> <li>Compressor protection ON</li> <li>Indoor fan tap</li> <li>Valid setting of silent mode</li> </ul>			

Note:

Error code Remote control: None	LED	Green	Red	Content <b>Operates but does not heat</b>
	Indoor	Keeps flashing	Stays OFF	
	Outdoor	Keeps flashing	Stays OFF	

1. Applicable model
All models
2. Error detection method
3. Condition of error displayed
4. Presumable cause
<ul style="list-style-type: none"> <li>Faulty 4-way valve operation</li> <li>Poor compression of compressor</li> <li>Faulty expansion valve operation</li> </ul>

5. Troubleshooting				
<table border="1"> <thead> <tr> <th>Diagnosis</th> <th>Countermeasure</th> </tr> </thead> <tbody> <tr> <td> <p>Check the indoor fan operation. Check the temperature difference between return and supply air.</p> <p>Is the temperature difference between return and supply air 10-30°C at heating?</p> <p>NO</p> <p>Is the compressor operating?</p> <p>NO</p> <p>“WAIT” message is displayed (for 3 seconds) when performing cooling, defrosting and heating operations from the remote control.</p> <p>NO</p> <p>Is the compressor rotation speed low?</p> <p>NO</p> <p>Check which control “Determination control of compressor rotation speed” or “Protective control by controlling compressor rotation speed” is appropriate to this phenomenon.</p> <p>Are the (1) temperature conditions of room and outdoor air close to the rated conditions?</p> <p>NO</p> <p>The unit is operating normally but is operating under the control for protecting compressor or other respective parts.</p> </td> <td> <p>It is normal. (This unit is designed to start in the soft start mode by detecting the under dome temperature of compressor when it restart after power reset.)</p> <p>It is necessary to replace to higher capacity one or to install additional unit.</p> <p>Compressor refrigerant oil protection control at starting is activated. For the contents of control, refer to the compressor start control of the microcomputer control functions.</p> <p>Compressor may be stopped by the error detection control. For the contents of control, refer to anomalous stop control by controlling compressor rotation speed of microcomputer control functions.</p> <p>Inspect the followings.</p> <ul style="list-style-type: none"> <li>Minor clogging of filter</li> <li>Minor clogging of heat exchanger</li> <li>Minor short-circuit</li> <li>Minor shortage of refrigerant amount</li> <li>Poor compression of compressor</li> </ul> <p>Considering appropriate operation control, check suspicious points. Inspect the followings for reference.</p> <ul style="list-style-type: none"> <li>Major clogging of filter</li> <li>Major clogging of heat exchanger</li> <li>Major short-circuit</li> <li>Major shortage of refrigerant amount</li> <li>Compressor protection ON</li> <li>Indoor fan tap</li> <li>Valid setting of silent mode</li> </ul> </td> </tr> </tbody> </table>	Diagnosis	Countermeasure	<p>Check the indoor fan operation. Check the temperature difference between return and supply air.</p> <p>Is the temperature difference between return and supply air 10-30°C at heating?</p> <p>NO</p> <p>Is the compressor operating?</p> <p>NO</p> <p>“WAIT” message is displayed (for 3 seconds) when performing cooling, defrosting and heating operations from the remote control.</p> <p>NO</p> <p>Is the compressor rotation speed low?</p> <p>NO</p> <p>Check which control “Determination control of compressor rotation speed” or “Protective control by controlling compressor rotation speed” is appropriate to this phenomenon.</p> <p>Are the (1) temperature conditions of room and outdoor air close to the rated conditions?</p> <p>NO</p> <p>The unit is operating normally but is operating under the control for protecting compressor or other respective parts.</p>	<p>It is normal. (This unit is designed to start in the soft start mode by detecting the under dome temperature of compressor when it restart after power reset.)</p> <p>It is necessary to replace to higher capacity one or to install additional unit.</p> <p>Compressor refrigerant oil protection control at starting is activated. For the contents of control, refer to the compressor start control of the microcomputer control functions.</p> <p>Compressor may be stopped by the error detection control. For the contents of control, refer to anomalous stop control by controlling compressor rotation speed of microcomputer control functions.</p> <p>Inspect the followings.</p> <ul style="list-style-type: none"> <li>Minor clogging of filter</li> <li>Minor clogging of heat exchanger</li> <li>Minor short-circuit</li> <li>Minor shortage of refrigerant amount</li> <li>Poor compression of compressor</li> </ul> <p>Considering appropriate operation control, check suspicious points. Inspect the followings for reference.</p> <ul style="list-style-type: none"> <li>Major clogging of filter</li> <li>Major clogging of heat exchanger</li> <li>Major short-circuit</li> <li>Major shortage of refrigerant amount</li> <li>Compressor protection ON</li> <li>Indoor fan tap</li> <li>Valid setting of silent mode</li> </ul>
Diagnosis	Countermeasure			
<p>Check the indoor fan operation. Check the temperature difference between return and supply air.</p> <p>Is the temperature difference between return and supply air 10-30°C at heating?</p> <p>NO</p> <p>Is the compressor operating?</p> <p>NO</p> <p>“WAIT” message is displayed (for 3 seconds) when performing cooling, defrosting and heating operations from the remote control.</p> <p>NO</p> <p>Is the compressor rotation speed low?</p> <p>NO</p> <p>Check which control “Determination control of compressor rotation speed” or “Protective control by controlling compressor rotation speed” is appropriate to this phenomenon.</p> <p>Are the (1) temperature conditions of room and outdoor air close to the rated conditions?</p> <p>NO</p> <p>The unit is operating normally but is operating under the control for protecting compressor or other respective parts.</p>	<p>It is normal. (This unit is designed to start in the soft start mode by detecting the under dome temperature of compressor when it restart after power reset.)</p> <p>It is necessary to replace to higher capacity one or to install additional unit.</p> <p>Compressor refrigerant oil protection control at starting is activated. For the contents of control, refer to the compressor start control of the microcomputer control functions.</p> <p>Compressor may be stopped by the error detection control. For the contents of control, refer to anomalous stop control by controlling compressor rotation speed of microcomputer control functions.</p> <p>Inspect the followings.</p> <ul style="list-style-type: none"> <li>Minor clogging of filter</li> <li>Minor clogging of heat exchanger</li> <li>Minor short-circuit</li> <li>Minor shortage of refrigerant amount</li> <li>Poor compression of compressor</li> </ul> <p>Considering appropriate operation control, check suspicious points. Inspect the followings for reference.</p> <ul style="list-style-type: none"> <li>Major clogging of filter</li> <li>Major clogging of heat exchanger</li> <li>Major short-circuit</li> <li>Major shortage of refrigerant amount</li> <li>Compressor protection ON</li> <li>Indoor fan tap</li> <li>Valid setting of silent mode</li> </ul>			

Note:

Error code Remote control: None	LED	Green	Red	Content <b>Earth leakage breaker activated</b>
	Indoor	Stays OFF	Stays OFF	
	Outdoor	Stays OFF	Stays OFF	

<b>1. Applicable model</b>
All models
<b>2. Error detection method</b>
<b>3. Condition of error displayed</b>
<b>4. Presumable cause</b>
<ul style="list-style-type: none"> <li>• Defective compressor</li> <li>• Noise</li> </ul>

<b>5. Troubleshooting</b>	
<b>Diagnosis</b>	<b>Countermeasure</b>
<pre> graph TD     D1{Are OK the insulation resistance and resistance between terminals (1) of compressor?}     D2{Is insulation of respective harnesses OK? Is any harness bitten between pannel and casing or etc?}     P1[Check the outdoor unit grounding wire/earth leakage breaker.]          D1 -- NO --&gt; C1[Replace compressor.*]     D1 -- YES --&gt; D2     D2 -- NO --&gt; C2[Secure insulation resistance.]     D2 -- YES --&gt; P1     </pre>	
<p>Check of the outdoor unit grounding wire/earth leakage breaker</p> <p>① Run an independent grounding wire from the grounding screw of outdoor unit to the grounding terminal on the distribution panel. (Do not connect to another grounding wire.)</p> <p>② In order to prevent malfunction of the earth leakage breaker itself, confirm that it is conformed to higher harmonic regulation.</p> <p>* Insulation resistance of compressor</p> <ul style="list-style-type: none"> <li>• Immediately after installation or when the unit has been left for long time without power source, the insulation resistance may drop to a few MΩ because of refrigerant migrated in the compressor.</li> </ul> <p>When the earth breaker is activated at lower insulation resistance, check the following points.</p> <p>① 6 hours after power ON, check if the insulation resistance recovers to normal. (FDC71-250 only)</p> <p>When power ON, crankcase heater heat up compressor and evaporate the refrigerant migrated in the compressor.</p> <p>② Check if the earth leakage breaker is conformed to higher harmonic regulation or not.</p> <p>Since the unit is equipped with inverter, it is necessary to use components conformed to higher harmonic regulation in order to prevent malfunction of earth leakage breaker.</p>	

Note:



Error code Remote control: None	LED	Green	Red	Content <b>Excessive noise/vibration (1/3)</b>
	Indoor	—	—	
	Outdoor	—	—	

**1. Applicable model**  
All models

**2. Error detection method**

**3. Condition of error displayed**

- 4. Presumable cause**
- ① Improper installation work
    - Improper anti-vibration work at installation
    - Insufficient strength of mounting face
  - ② Defective product
    - Before/after shipping from factory
  - ③ Improper adjustment during commissioning
    - Excess/shortage of refrigerant, etc.

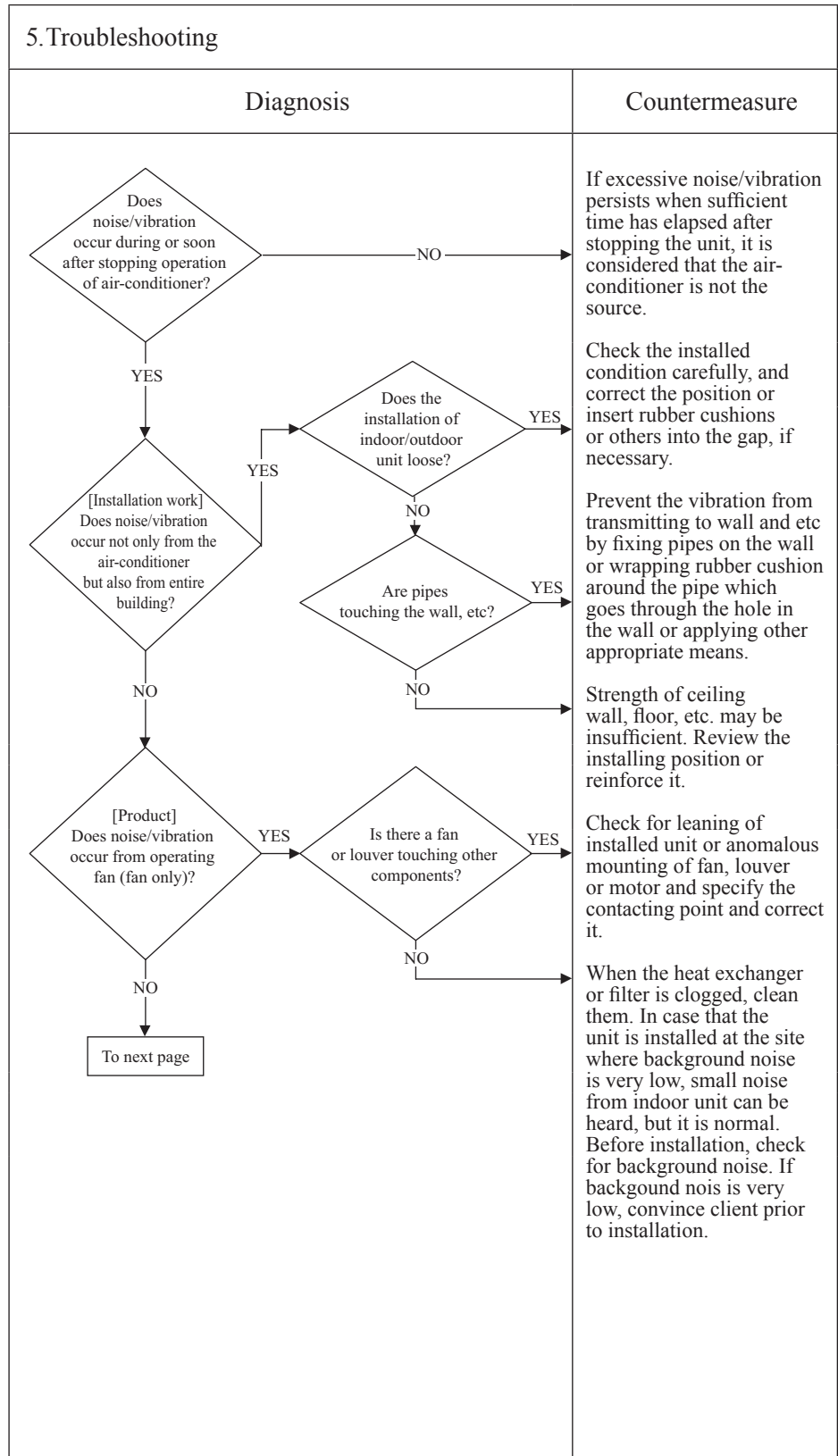

**Note:**

Error code Remote control: None	LED	Green	Red	Content <b>Excessive noise/vibration (2/3)</b>
	Indoor	-	-	
	Outdoor	-	-	

<b>1. Applicable model</b>
All models
<b>2. Error detection method</b>
<b>3. Condition of error displayed</b>
<b>4. Presumable cause</b>

<b>5. Troubleshooting</b>	
<b>Diagnosis</b>	<b>Countermeasure</b>

Note:

Error code Remote control: None	LED	Green	Red	Content <b>Excessive noise/vibration (3/3)</b>
	Indoor	–	–	
	Outdoor	–	–	

<p>1. Applicable model</p> <p>All models</p>	5. Troubleshooting	
<p>2. Error detection method</p>	Diagnosis	Countermeasure
<p>3. Condition of error displayed</p>	<pre> graph TD     A[From previous page] --&gt; B{Adjustment during commissioning Does noise/vibration occur when the cooling/heating operation is in anomalous condition?}     B -- YES --&gt; C[Countermeasure]             </pre>	
<p>4. Presumable cause</p>	<p>If insufficient cooling/heating problem happens due to anomalous operating conditions at cooling/heating, followings are suspicious.</p> <ul style="list-style-type: none"> <li>• Overcharge of refrigerant</li> <li>• Insufficient charge of refrigerant</li> <li>• Intrusion of air, nitrogen, etc.</li> </ul> <p>In such occasion, it is necessary to recover refrigerant, vacuum-dry and recharge refrigerant.</p> <p>* Since there could be many causes of noise/vibration, the above do not cover all. In such case, check the conditions when, where, how the noise/vibration occurs according to following check point.</p> <ul style="list-style-type: none"> <li>• Indoor/outdoor unit</li> <li>• Cooling/heating/fan mode</li> <li>• Startup/stop/during operation</li> <li>• Operating condition (Indoor/outdoor temperatures, pressure)</li> <li>• Time it occurred</li> <li>• Operation data retained by the remote control such as compressor rotation speed, heat exchanger temperature, EEV opening degree, etc.</li> <li>• Tone (If available, record the noise)</li> <li>• Any other anomalies</li> </ul>	

Note:

Error code Remote control: None	LED	Green	Red	Content <b>Louver motor failure</b>
	Indoor	Keeps flashing	Stays OFF	
	Outdoor	Keeps flashing	Stays OFF	

<b>1. Applicable model</b>
All models

<b>2. Error detection method</b>

<b>3. Condition of error displayed</b>

<b>4. Presumable cause</b>
<ul style="list-style-type: none"> <li>• Defective LM</li> <li>• LM wire breakage</li> <li>• Faulty indoor unit control PCB</li> </ul>

<b>5. Troubleshooting</b>	
<b>Diagnosis</b>	<b>Countermeasure</b>
<p>▲ Check at the indoor unit side.</p> <pre> graph TD     Start[Operate after waiting for more than 1 minute.] --&gt; Q1{Does the louver operate at the power on?}     Q1 -- NO --&gt; Q2{Is LM wiring broken?}     Q2 -- YES --&gt; C1[Repair wiring.]     Q2 -- NO --&gt; Q3{Is LM locked?}     Q3 -- NO --&gt; C2[Defective indoor unit control PCB → Replace.]     Q3 -- YES --&gt; C3[Replace LM.]     Q1 -- YES --&gt; Q4{Is the louver operable with the remote control?}     Q4 -- YES --&gt; C4[Normal]     Q4 -- NO --&gt; C5[Adjust LM lever and then check again.]                     </pre> <p style="text-align: center;">LM: louver motor</p>	

Note:

<b>Error code</b> Remote control: None	LED	Green	Red	<b>Content</b> Power source system error (Power source to indoor unit control PCB)
	Indoor	Stays OFF	Stays OFF	
	Outdoor	Keeps flashing	2-time flash	

<b>1. Applicable model</b> All models
<b>2. Error detection method</b>
<b>3. Condition of error displayed</b>
<b>4. Presumable cause</b> <ul style="list-style-type: none"> <li>• Misconnection or breakage of connecting wires</li> <li>• Blown fuse</li> <li>• Faulty transformer</li> <li>• Faulty indoor unit control PCB</li> <li>• Broken harness</li> <li>• Faulty outdoor unit control PCB (Noise filter)</li> </ul>

5. Troubleshooting	
Diagnosis	Countermeasure
<pre>                     graph TD                         D1{Is AC220/240V detected between ① and ② on the terminal block of indoor unit?}                         D2{Are fuses OK (F1,2)}                         D3{Is DC5V detected between ④-⑤ of CNW2?}                         D4{Is JX1 open?}                         D5{Is AC380/415V for 3-phase unit detected between ①, ② and ③ on the terminal block of outdoor unit or is AC220/240V for 1-phase unit detected between ① and ② on the terminal block of outdoor unit?}                         D6{Is the check of resistance between ①-③ of CNW0 OK?}                         D7{Is the checked result of resistance of FM, LM, etc OK?}                          D1 -- YES --&gt; D2                         D1 -- NO --&gt; D5                         D2 -- YES --&gt; D3                         D2 -- NO --&gt; D5                         D3 -- YES --&gt; D4                         D3 -- NO --&gt; C1[Defective indoor unit control PCB -&gt; Replace.]                         D4 -- YES --&gt; C2[Defective indoor unit control PCB -&gt; Replace.]                         D4 -- NO --&gt; C3[Open JX1.]                         D5 -- YES --&gt; C4[Misconnection or breakage of connecting wires.]                         D5 -- NO --&gt; C5[Defective outdoor unit control PCB (Noise filter).]                         D6 -- YES --&gt; C6[Replace fuse.]                         D6 -- NO --&gt; D7                         D7 -- YES --&gt; C7[Replace FM, LM, etc.]                         D7 -- NO --&gt; C8[Defective indoor unit control PCB -&gt; Replace.]                     </pre>	Countermeasure

Note:

Error code Remote control: None	LED	Green	Red	Content <b>Power source system error (Power source to remote control)</b>
	Indoor	Keeps flashing	Stays OFF	
	Outdoor	Keeps flashing	2-time flash	

<b>1. Applicable model</b>
All models

<b>2. Error detection method</b>

<b>3. Condition of error displayed</b>

<b>4. Presumable cause</b>
<ul style="list-style-type: none"> <li>• Remote control wire breakage/short-circuit</li> <li>• Defective remote control</li> <li>• Malfunction by noise</li> <li>• Broken harness</li> <li>• Faulty indoor unit control PCB</li> </ul>

<b>5. Troubleshooting</b>	
<b>Diagnosis</b>	<b>Countermeasure</b>
<pre> graph TD     D1{Is the connection of the remote control's wiring OK? X (white), Y (black)} -- NO --&gt; C1[Correct.]     D1 -- YES --&gt; D2{Does the voltage between X and Y in the indoor terminal block exceed 15 VDC?}     D2 -- NO --&gt; A1[Remove wire for the remote control]     D2 -- YES --&gt; A2[Power source reset]     A2 --&gt; D3{Does resetting the power source return it to normal?}     D3 -- YES --&gt; C2[Remote control wire breakage? Replace remote control. Malfunction by temporary noise.]     D3 -- NO --&gt; C3[Defective indoor unit control PCB -&gt; Replace.]     A1 --&gt; D4{Does the re-measured voltage between X and Y in the indoor terminal block exceed 15 VDC?}     D4 -- YES --&gt; C4[Remote control wire breakage? Replace remote control.]     D4 -- NO --&gt; C3     </pre>	

Note:

Error code Remote control: INSPECT I/U	LED	Green	Red	Content <b>INSPECT I/U</b> (When 1 or 2 remote controls are connected)
	Indoor	Keeps flashing	Stays OFF	
	Outdoor	Keeps flashing	2-time flash	

<b>1. Applicable model</b>
All models
<b>2. Error detection method</b>
Communication between indoor unit and remote control is disabled for more than 30 minutes after the power on.
<b>3. Condition of error displayed</b>
Same as above
<b>4. Presumable cause</b>
<ul style="list-style-type: none"> <li>• Improper setting</li> <li>• Surrounding environment</li> <li>• Defective remote control communication circuit</li> <li>• Faulty indoor unit control PCB</li> </ul>

<b>5. Troubleshooting</b>	
<b>Diagnosis</b>	<b>Countermeasure</b>
<pre> graph TD     Q1{Are 2 units of remote control connected?}     Q2{Does it become normal?}     Q3{Is it set at the slave remote control?}     Q4{Do more than one indoor units have the same address?}     Q5{Are remote control wires laid along high voltage wires?}     Q6{Does DM start 60 seconds later automatically.}          Q1 -- YES --&gt; S1[Set one remote control for "Master" and the other for "Slave"]     S1 --&gt; Q2     Q2 -- NO --&gt; Q3     Q3 -- YES --&gt; S2[Set SW1 on remote control PCB at "Master".]     Q3 -- NO --&gt; Q4     Q4 -- YES --&gt; S3[Set address again. (SW2 on indoor unit control PCB)]     Q4 -- NO --&gt; Q5     Q5 -- YES --&gt; S4[Separate remote control wires from high voltage wires.]     Q5 -- NO --&gt; S5[Disconnect the connecting wire ③ between the indoor and outdoor unit.]     S5 --&gt; S6[Power source reset]     S6 --&gt; Q6     Q6 -- YES --&gt; S7[Defective indoor unit control PCB -&gt; Replace.]     Q6 -- NO --&gt; S8[Defective remote control -&gt; Change.]     </pre>	

Note: If any error is detected 30 minutes after displaying “WAIT” on the remote control, the display changes to “INSPECT I/U”.

Error code Remote control: INSPECT I/U	LED	Green	Red	Content <b>INSPECT I/U</b> (Connection of 3 units or more remote controls)
	Indoor	Keeps flashing	Stays OFF	
	Outdoor	Keeps flashing	2-time flash	

<b>1. Applicable model</b>
All models

<b>2. Error detection method</b>
Indoor unit cannot communicate for more than 30 minutes after the power on with remote control.

<b>3. Condition of error displayed</b>
Same as above

<b>4. Presumable cause</b>
<ul style="list-style-type: none"> <li>• Improper setting</li> <li>• Surrounding environment</li> <li>• Defective remote control communication circuit</li> <li>• Faulty indoor unit control PCB</li> <li>• Faulty outdoor unit control PCB</li> </ul>

<b>5. Troubleshooting</b>	
<b>Diagnosis</b>	<b>Countermeasure</b>

**Note:** If any error is detected 30 minutes after displaying “WAIT” on the remote control, the display changes to “INSPECT I/U”.



Error code Remote control:  WAIT	LED	Green	Red	Content <b>Communication error at initial operation (1/3)</b> (Models FDC71-140)
	Indoor	Keeps flashing	Stays OFF	
	Outdoor	Keeps flashing	2-time flash	

**1. Applicable model**  
Models FDC71-140

**2. Error detection method**

**3. Condition of error displayed**

- 4. Presumable cause**
- Faulty indoor unit control PCB
  - Defective remote control
  - Broken remote control wire
  - Faulty outdoor unit control PCB
  - Broken connection wires

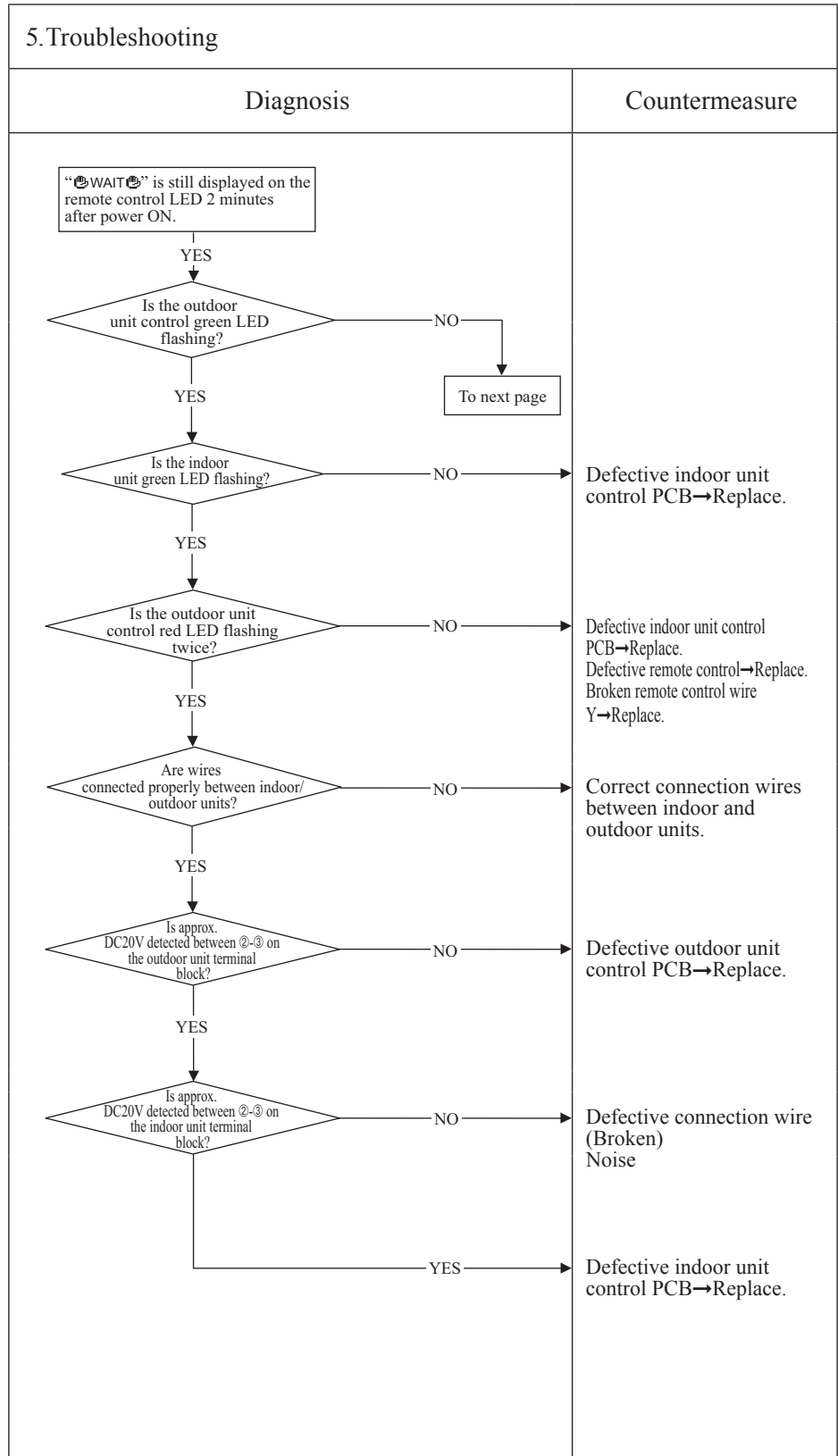

Note:

Error code Remote control: 🏠 WAIT 🏠	LED	Green	Red	Content <b>Communication error at initial operation (2/3)</b> (Models FDC71-140)
	Indoor	Keeps flashing	Stays OFF	
	Outdoor	Keeps flashing	2-time flash	

<b>1. Applicable model</b>
Models FDC71-140
<b>2. Error detection method</b>
<b>3. Condition of error displayed</b>
<b>4. Presumable cause</b>
<ul style="list-style-type: none"> <li>Faulty noise filter</li> <li>Faulty indoor unit control PCB</li> <li>Faulty outdoor unit control PCB</li> <li>Faulty inverter PCB</li> <li>Faulty fan motor</li> </ul>

5. Troubleshooting	Diagnosis	Countermeasure
	<p>Diagnosis for when the outdoor unit control PCB LED is turned off</p> <pre> graph TD     Start[From previous page] --&gt; Step1[Shut down the breaker and back on again the breaker 3 minutes later.]     Step1 --&gt; Dec1{Does it reset normally?}     Dec1 -- YES --&gt; C1[Normal (Malfunction by noise)]     Dec1 -- NO --&gt; Dec2{Is the outdoor unit control power source fuse (71:20A, 100-140:30A) blown?}     Dec2 -- YES --&gt; Note1[Note (1) 1-phase model only]     Note1 --&gt; Step2[To check method for inverter PCB before replacment of blown power source fuse.]     Step2 --&gt; Step3[To next page]     Dec2 -- NO --&gt; Dec3{Is AC220/240V or AC380/415V detected at the noise filter secondary side?}     Dec3 -- YES --&gt; Dec4{Is DC255-310V detected at CNA2?}     Dec4 -- YES --&gt; Dec5{Is fuse [250V, 2A] on the outdoor unit control PCB blown?}     Dec5 -- YES --&gt; C2[Defective outdoor unit control PCB -&gt; Replace.]     Dec5 -- NO --&gt; Dec6{Is DC5V detected on the outdoor unit control PCB (Between ①-④ of CNV)?}     Dec6 -- YES --&gt; Dec7{Is DC5V detected if the connector of outdoor fan motor is disconnected?}     Dec7 -- YES --&gt; C3[Defective outdoor unit control PCB -&gt; Replace.]     Dec7 -- NO --&gt; Dec8{Is DC5V detected if the inverter power source connector (CN12) is disconnected?}     Dec8 -- YES --&gt; C4[Defective outdoor unit control PCB -&gt; Replace.]     Dec8 -- NO --&gt; C5[Defective outdoor fan motor]     Dec3 -- NO --&gt; C6[Replace noise filter.]     Dec4 -- NO --&gt; C7[Check connection of diode stack and electrolytic capacitor by refering main electrical circuit diagram.]     </pre>	

Note:

Error code Remote control: 🗄️ WAIT 🗄️	LED	Green	Red	Content <b>Communication error at initial operation (3/3)</b> (Models FDC71-140)
	Indoor	Keeps flashing	Stays OFF	
	Outdoor	Keeps flashing	2-time flash	

**1. Applicable model**  
Models FDC71-140

**2. Error detection method**

**3. Condition of error displayed**

- 4. Presumable cause**
- Blown fuse
  - Faulty noise filter
  - Faulty inverter PCB
  - Faulty reactor
  - Faulty electrolytic capacitor

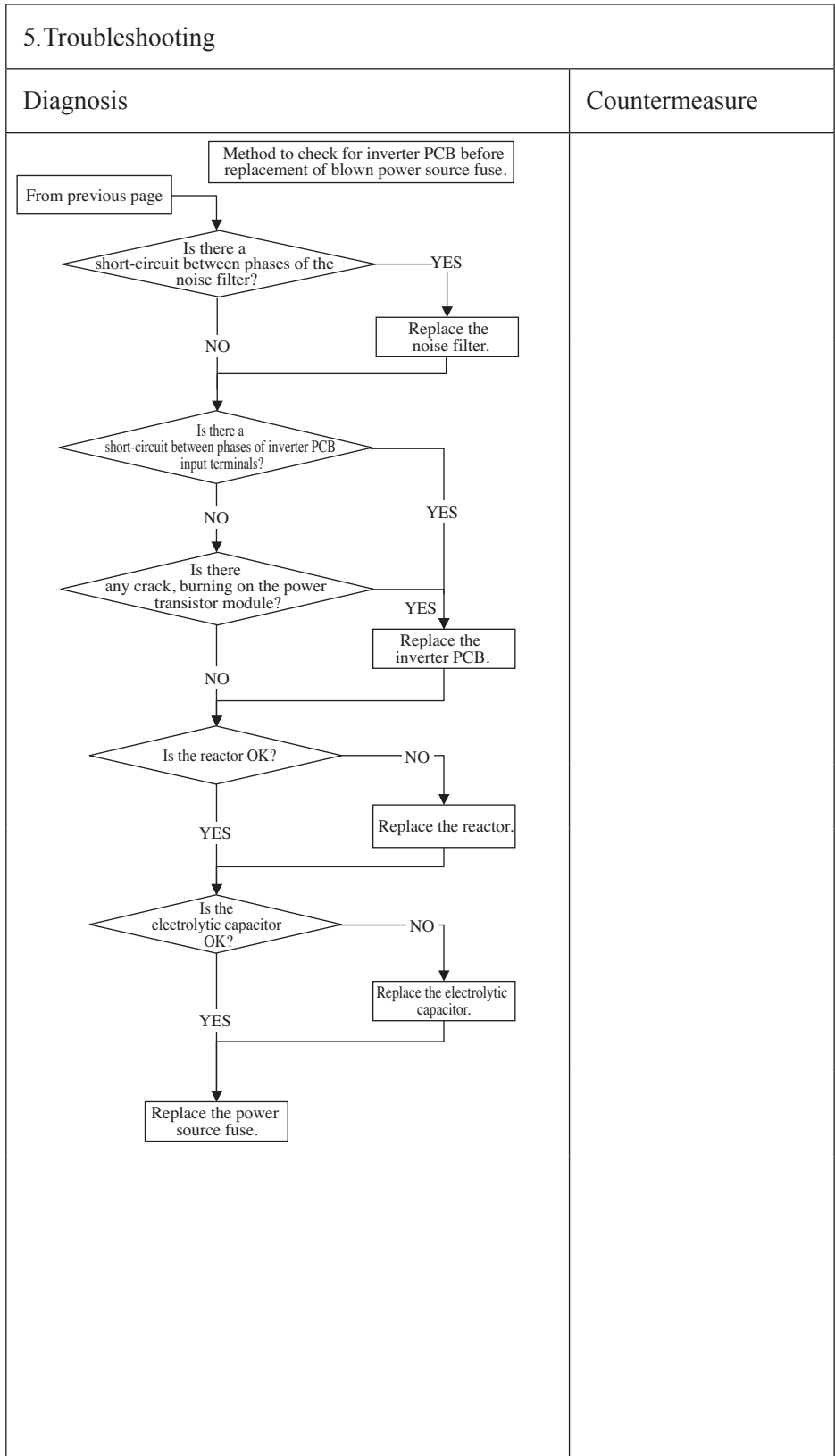

**Note:**

Error code Remote control: 🏠WAIT🏠	LED	Green	Red	Content <b>Communication error at initial operation (1/2)</b> (Models FDC200, 250VSA only)
	Indoor	Keeps flashing	Stays OFF	
	Outdoor	Keeps flashing	2-time flash	

**1. Applicable model**  
Models FDC200, 250VSA

**2. Error detection method**

**3. Condition of error displayed**

- 4. Presumable cause**
- Faulty indoor unit control PCB
  - Defective remote control
  - Broken remote control wire
  - Faulty outdoor unit control PCB
  - Broken connection wires

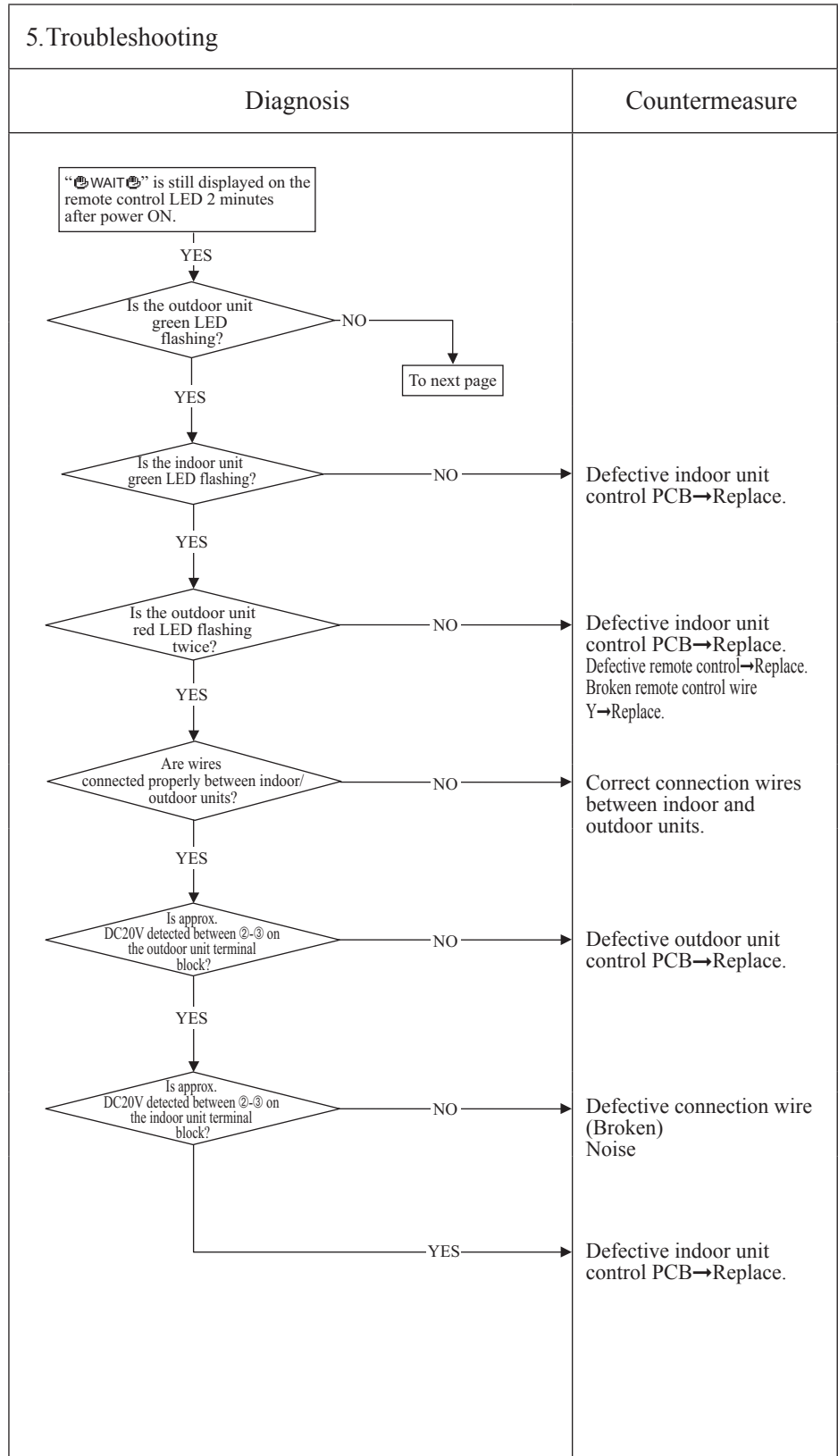

Note:

Error code Remote control: 🗄️ WAIT 🗄️	LED	Green	Red	Content <b>Communication error at initial operation (2/2)</b> (Models FDC200, 250VSA only)
	Indoor	Keeps flashing	Stays OFF	
	Outdoor	Keeps flashing	2-time flash	

**1. Applicable model**  
Models FDC200, 250VSA

**2. Error detection method**

**3. Condition of error displayed**

- 4. Presumable cause**
- Faulty noise filter
  - Faulty indoor unit control PCB
  - Faulty outdoor unit control PCB
  - Faulty inverter PCB
  - Faulty fan motor

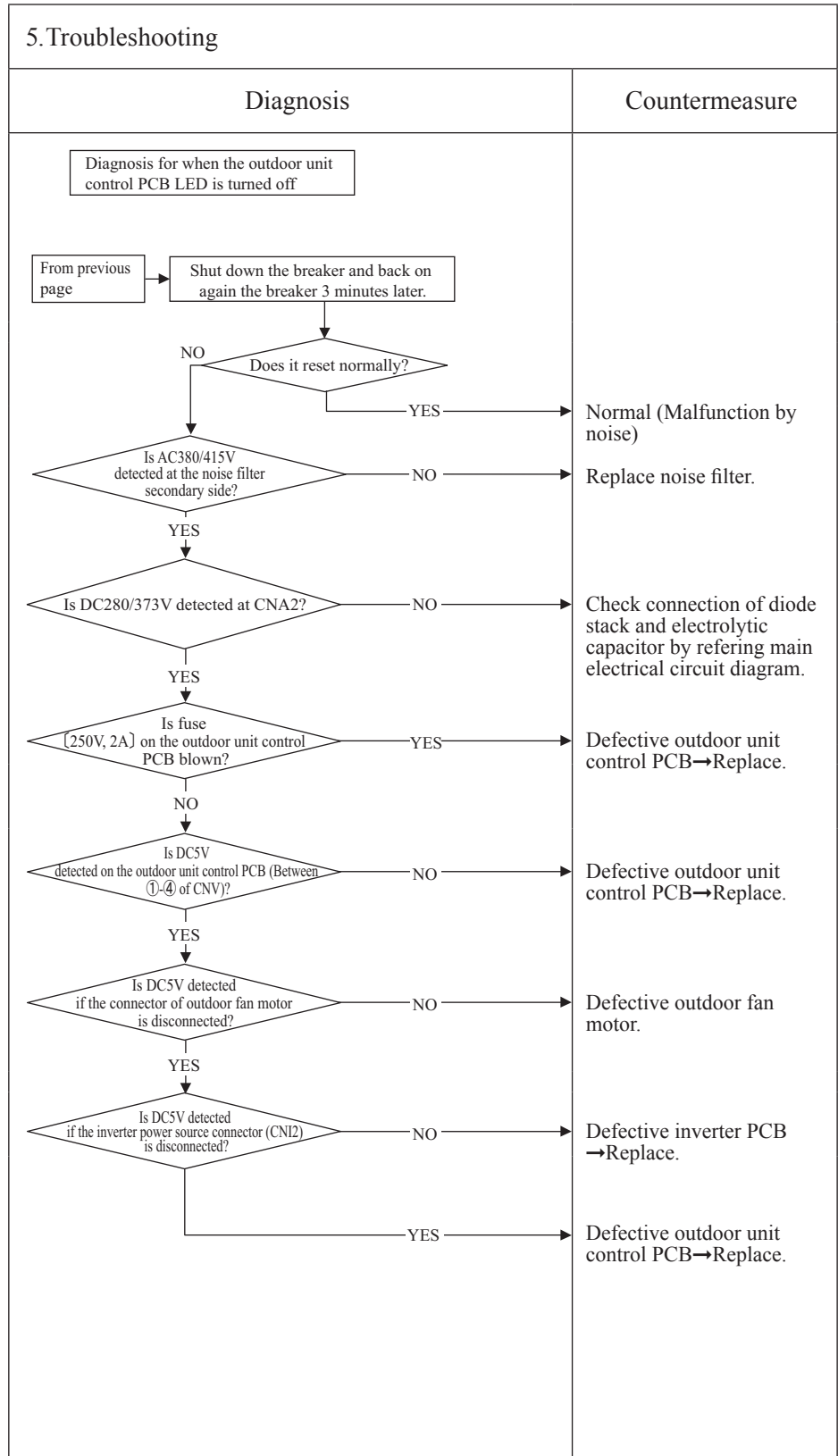

**Note:**

Error code Remote control: 🏠WAIT🏠	LED	Green	Red	Content <b>Communication error at initial operation (1/3)</b> (Models FDC71-100VNP only)
	Indoor	Keeps flashing	Stays OFF	

**1. Applicable model**  
Models FDC71-100VNP  
When the remote control LCD displays “🏠WAIT🏠” 2 minutes after the power on.

**2. Error detection method**

**3. Condition of error displayed**

- 4. Presumable cause**
- Blown fuse
  - Faulty outdoor unit PCB
  - Connection between PCB's
  - Faulty indoor unit control PCB
  - Defective remote control
  - Broken remote control wire

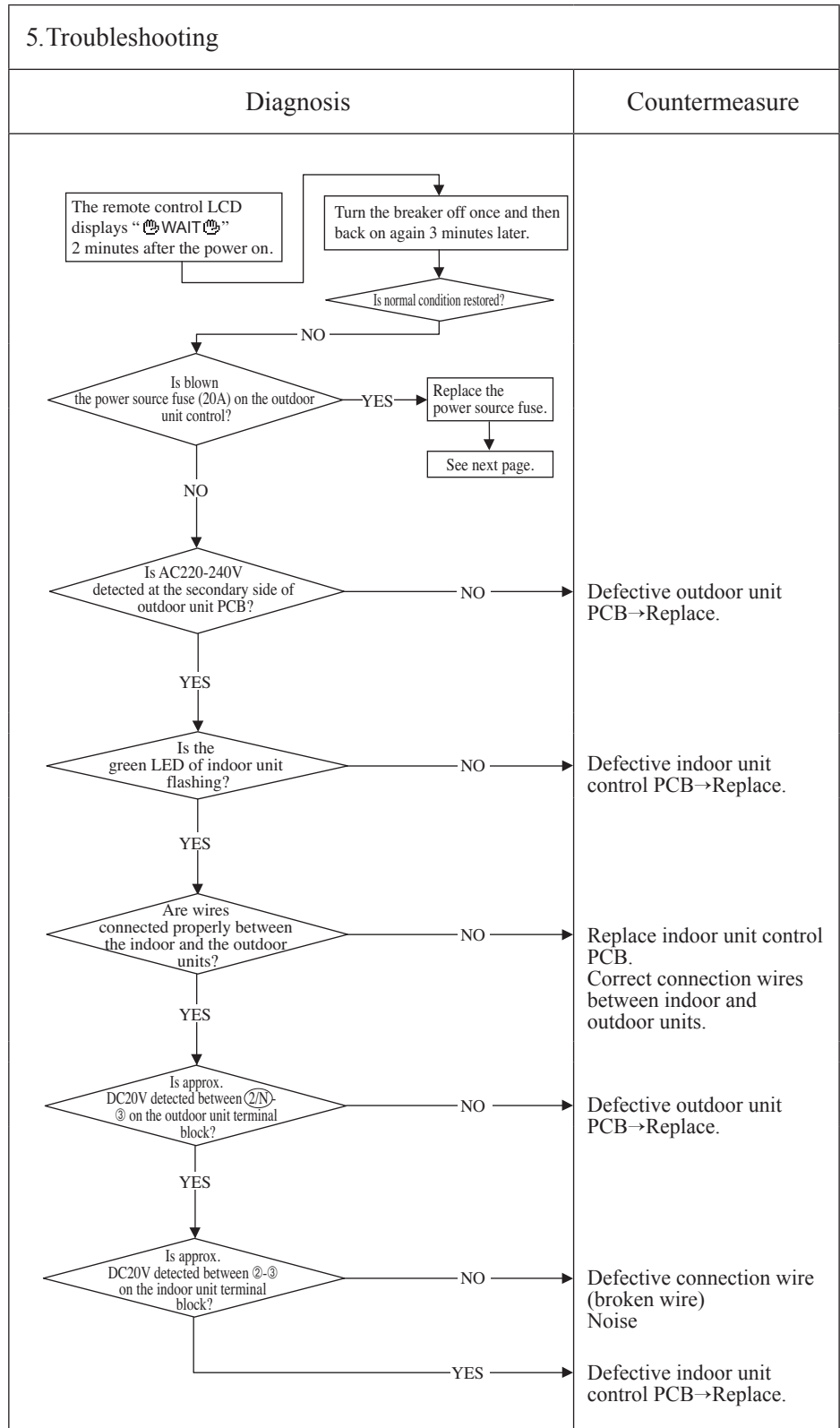

Note: If any anomaly is detected during communication, the error code E5 is displayed. Inspection procedure is same as above. (Excluding matters related to connection) When the power source is reset after the occurrence of E5, the LED will display “🏠WAIT🏠” if the anomaly continues. If the breaker ON/OFF is repeated in a short period of time (within 1 minute), “🏠WAIT🏠” may be displayed. In such occasion, turn the breaker off and wait for 3 minutes.

Error code Remote control: 🗄️ WAIT 🗄️	LED	Green	Red	Content <b>Communication error at initial operation (2/3)</b> (Models FDC71-100VNP only)
	Indoor	Keeps flashing	Stays OFF	

<p><b>1. Applicable model</b></p> <p>Models FDC71-100VNP</p> <p>When the fuse is blown, the method to inspect outdoor unit PCB before replacing the power source fuse</p>	<p><b>5. Troubleshooting</b></p>	
<p><b>2. Error detection method</b></p>	<p style="text-align: center;"><b>Diagnosis</b></p> <pre> graph TD     Start([From previous page]) --&gt; D1{Is there a short-circuit between phases of outdoor unit PCB?}     D1 -- YES --&gt; A1[Replace the outdoor unit PCB]     D1 -- NO --&gt; D2{Are there cracks or burning on the power transistor module or diode?}     D2 -- YES --&gt; A2[Replace the outdoor unit PCB]     D2 -- NO --&gt; D3{Is reactor the anomalous?}     D3 -- YES --&gt; A3[Replace the reactor.]     D3 -- NO --&gt; A4[Replace fuse.]     </pre>	<p style="text-align: center;"><b>Countermeasure</b></p> <p style="text-align: center;">Replace fuse.</p>
<p><b>3. Condition of error displayed</b></p>		
<p><b>4. Presumable cause</b></p> <ul style="list-style-type: none"> <li>• Blown fuse</li> <li>• Faulty outdoor unit PCB</li> <li>• Faulty reactor</li> </ul>		

Note:

Error code Remote control: 🏠WAIT🏠	LED	Green	Red	Content <b>Communication error at initial operation (3/3)</b> (FDC71-100VNP only)
	Indoor	Keeps flashing	Stays OFF	

**1. Applicable model**

Models FDC71-100VNP

When the remote control display is extinguished after the power on.

**2. Error detection method**

**3. Condition of error displayed**

- 4. Presumable cause**
- Blown fuse
  - Connection between PCB's
  - Blown fuse
  - Faulty indoor unit control PCB
  - Defective remote control
  - Wire breakage on remote control
  - Faulty outdoor unit PCB

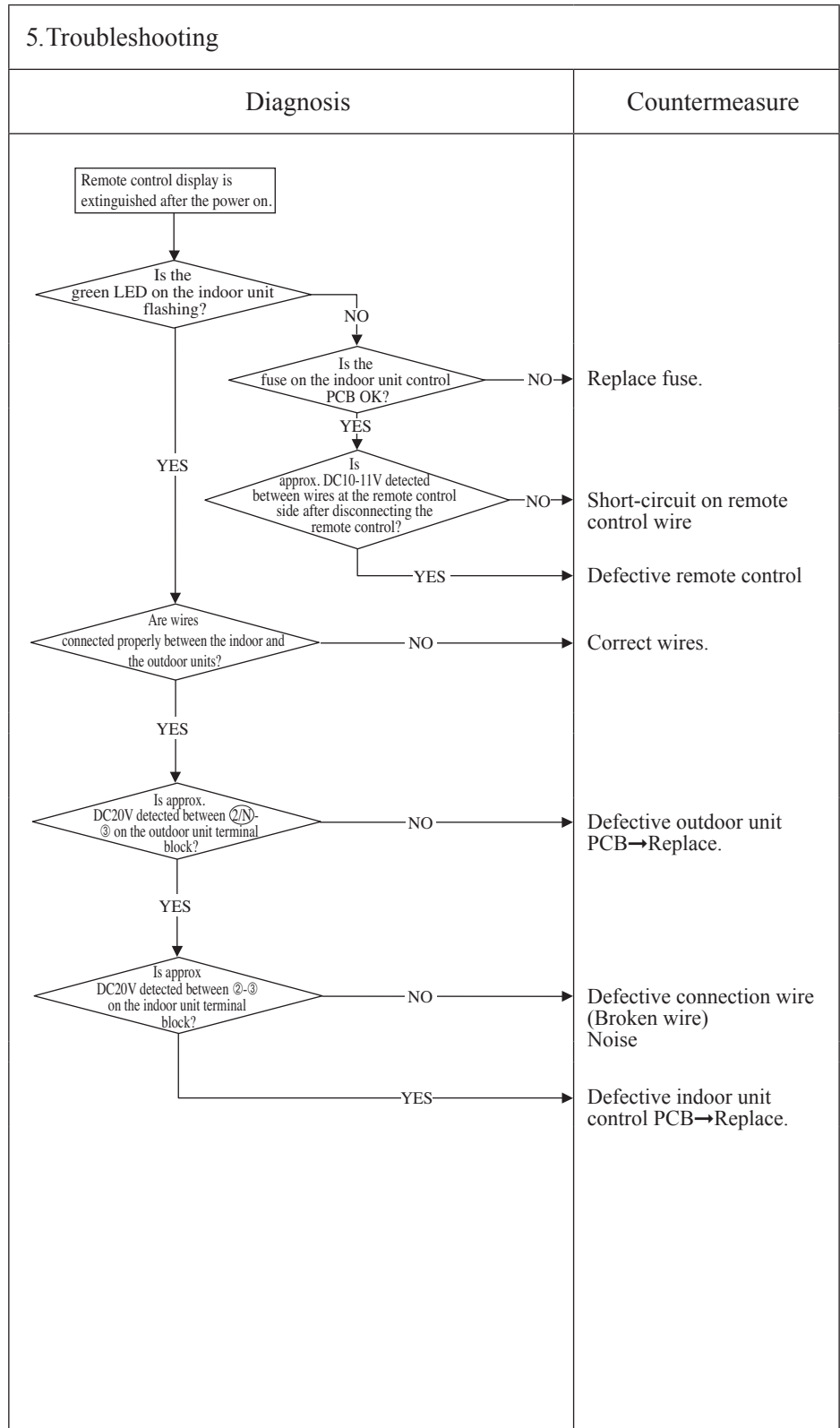

Note:



Error code Remote control: None	LED	Green	Red	Content  <b>No display</b>
	Indoor	Stays OFF	Stays OFF	
	Outdoor	Stays OFF	Stays OFF	

<b>1. Applicable model</b>
All models
<b>2. Error detection method</b>
<b>3. Condition of error displayed</b>
<b>4. Presumable cause</b>
<ul style="list-style-type: none"> <li>• Faulty indoor unit control PCB</li> <li>• Defective remote control</li> <li>• Broken remote control wire</li> </ul>

5. Troubleshooting	
Diagnosis	Countermeasure
<pre> graph TD     Start[Remote control does not display anything after the power on.] --&gt; D1{Is DC10V or higher detected at remote control connection terminals?}     D1 -- YES --&gt; C1[Defective remote control]     D1 -- NO --&gt; D2{Is DC10V or higher detected on remote control wires if the remote control is removed?}     D2 -- YES --&gt; C2[Defective remote control]     D2 -- NO --&gt; D3{Are wires connected properly between the indoor/outdoor units?}     D3 -- YES --&gt; C3[Defective connecting wire Defective remote control wire (Short-circuit, etc.)]     D3 -- NO --&gt; C4[Defective indoor unit control PCB -&gt; Replace.]         </pre>	

Note:

Error code Remote control: E1	LED	Green	Red	Content
	Indoor	Keeps flashing	Stays OFF	
	Outdoor	Keeps flashing	Stays OFF	

## Remote control communication circuit error

<b>1. Applicable model</b>	<b>5. Troubleshooting</b>		
All models	<b>Diagnosis</b>	<b>Countermeasure</b>	
<b>2. Error detection method</b>	<pre> graph TD     A{Is it possible to reset normally by the power reset?} -- YES --&gt; B[Malfunction by noise Check peripheral environment.]     A -- NO --&gt; C[Turn SW7-1 to OFF. → ON Remove the wire ③ connecting between indoor/outdoor units.]     C --&gt; D[Power source reset]     D --&gt; E{Does the drain pump restart automatically 1 minute later? (1)}     E -- YES --&gt; F[Defective indoor unit control PCB → Replace.]     E -- NO --&gt; G[Connect the wire ③ connecting between indoor/outdoor units.]     G --&gt; H[Move to E5. (Communication error during operation) Check.]     </pre>		
When normal communication between the remote control and the indoor unit is interrupted for more than 2 minutes. (Detectable only with the remote control)			
<b>3. Condition of error displayed</b>			
Same as above			
<b>4. Presumable cause</b>			
<ul style="list-style-type: none"> <li>• Defective communication circuit between remote control-indoor unit</li> <li>• Noise</li> <li>• Defective remote control</li> <li>• Faulty indoor unit control PCB</li> </ul>			

**Note:** If the indoor unit cannot communicate normally with the remote control for 180 seconds, the indoor unit PCB starts to reset automatically.

Error code Remote control: E5	LED	Green	Red	Content <b>Communication error during operation</b>
	Indoor	Keeps flashing	2-time flash	
	Outdoor	Keeps flashing	See below	

<b>1. Applicable model</b>
All models
<b>2. Error detection method</b>
When normal communication between indoor and outdoor unit is interrupted for more than 2 minutes.
<b>3. Condition of error displayed</b>
Same as above is detected during operation.
<b>4. Presumable cause</b>
<ul style="list-style-type: none"> <li>• Unit No. setting error</li> <li>• Broken remote control wire</li> <li>• Faulty remote control wire connection</li> <li>• Faulty outdoor unit control PCB</li> </ul>

<b>5. Troubleshooting</b>	
<b>Diagnosis</b>	<b>Countermeasure</b>
<p>● In case that the outdoor unit red LED flashes 2-time</p> <p>Note (1) Inspect faulty connections (disconnection, looseness) on the outdoor unit terminal block.</p> <p>Is the connection of signal wires at the outdoor unit side OK?</p> <p>NO → Repair signal wires.</p> <p>YES</p> <p>Note (2) Check for faulty connection or breakage of signal wires between indoor-outdoor units.</p> <p>Is the connection of signal wires between indoor-outdoor units OK?</p> <p>NO → Repair signal wires.</p> <p>YES</p> <p>Power source reset</p> <p>Has the remote control LCD returned to normal state?</p> <p>NO → To the diagnosis of “WAIT”.</p> <p>YES → Unit is normal. (Malfunction by temporary noise, etc.)</p> <p>● In case that the outdoor unit red LED stays OFF (Except for FDC90VNP1, 100VNP)</p> <p>Power source reset</p> <p>NO</p> <p>Has the remote control LCD returned to normal state?</p> <p>NO → Defective outdoor unit PCB (Defective network communication circuit) → Replace.</p> <p>YES → Unit is normal. (Malfunction by temporary noise, etc.)</p>	

Note: Pressing the pump-down switch cancels communications between indoor and outdoor unit so that “communication error-E5” is displayed on indoor unit and remote control, but it is normal. (Except for FDC90VNP1, 100VNP)

Error code Remote control: E6	LED	Green	Red	Content <b>Indoor heat exchanger temperature sensor anomaly</b>
	Indoor	Keeps flashing	1-time flash	
	Outdoor	Keeps flashing	Stays OFF	

**1. Applicable model**  
All models

**2. Error detection method**  
Anomalously low temperature or high temperature (resistance) is detected on the indoor heat exchanger temperature sensor (Thi-R1, R2 or R3).

**3. Condition of error displayed**

- When the temperature sensor detects -50°C or lower for 5 seconds continuously, the compressor stops. After 3-minute delay, the compressor starts again automatically, but if this error occurs again within 60 minutes after the initial detection.
- Or if 70°C or higher is detected for 5 seconds continuously.

**4. Presumable cause**

- Defective indoor heat exchanger temperature sensor connector
- Indoor heat exchanger temperature sensor anomaly
- Faulty indoor unit control PCB

**5. Troubleshooting**

Diagnosis	Countermeasure
<p>Is the connection of indoor heat exchanger temperature sensor connector OK?</p> <p>NO →</p> <p>YES →</p> <p>Are characteristics of indoor heat exchanger temperature sensor OK?</p> <p>NO →</p> <p>YES →</p>	<p>Correct. → Insert connector securely.</p> <p>Defective indoor heat exchanger temperature sensor → Replace.</p> <p>Defective indoor unit control PCB → Replace. (Defective indoor heat exchanger temperature sensor input circuit)</p>

(Broken wire) **Temperature-resistance characteristic**

Temperature (°C)	Temperature sensor resistance (kΩ)
0	~16
10	~11
20	~7
25	5
30	~4
40	~3
50	~2

(Short-circuit)

Note:

Error code Remote control: E7	LED	Green	Red	Content <b>Return air temperature sensor anomaly</b>
	Indoor	Keeps flashing	1-time flash	
	Outdoor	Keeps flashing	Stays OFF	

**1. Applicable model**  
All models

**2. Error detection method**  
Anomalously low temperature or high temperature (resistance) is detected by indoor return air temperature sensor (Thi-A)

**3. Condition of error displayed**

- When the temperature sensor detects  $-50^{\circ}\text{C}$  or lower for 5 seconds continuously, the compressor stops. After 3-minute delay, the compressor starts again automatically, but if this error occurs again within 60 minutes after the initial detection.

**4. Presumable cause**

- Defective return air temperature sensor connector
- Defective return air temperature sensor
- Faulty indoor unit control PCB

**5. Troubleshooting**

Diagnosis	Countermeasure
<p>Is the connection of return air temperature sensor connector OK?</p> <p>NO →</p> <p>YES →</p> <p>Are the characteristics of return air temperature sensor OK?</p> <p>NO →</p> <p>YES →</p>	<p>Correct. → Connect connector.</p> <p>Defective return air temperature sensor → Replace.</p> <p>Defective indoor unit control PCB → Replace. (Defective return air temperature sensor input circuit)</p>

Temperature-resistance characteristic

Temperature (°C)	Temperature sensor resistance (kΩ)
0	15
10	10
20	7
25	5
30	4
40	3
50	2

Note:

Error code Remote control: E8	LED	Green	Red	Content <b>Heating overload operation</b>
	Indoor	Keeps flashing	1-time flash	
	Outdoor	Keeps flashing	Stays OFF	

**1. Applicable model**  
All models

**2. Error detection method**  
Indoor heat exchanger temperature sensor (Thi-R1, R2, R3)

**3. Condition of error displayed**  
When it is detected 5 times within 60 minutes from initial detection or when the overload condition is detected for 6 minutes continuously.

- 4. Presumable cause**
- Clogged air filter
  - Defective indoor heat exchanger temperature sensor connector
  - Defective indoor heat exchanger temperature sensor
  - Anomalous refrigerant system

**5. Troubleshooting**

Diagnosis	Countermeasure
<pre> graph TD     Q1{Is the air filter clogged?} -- YES --&gt; C1[Wash.]     Q1 -- NO --&gt; Q2{Is the indoor heat exchanger temperature sensor connection OK?}     Q2 -- NO --&gt; C2[Defective indoor heat exchanger temperature sensor connector → Correct.]     Q2 -- YES --&gt; Q3{Are the characteristics of indoor heat exchanger temperature sensor OK? (2)}     Q3 -- NO --&gt; C3[Defective indoor heat exchanger temperature sensor]     Q3 -- YES --&gt; R1[Check the error data with the remote control.]     R1 --&gt; Q4{Is the unit operating in the state of heating overload?}     Q4 -- NO --&gt; C4[Check refrigerant system.]     Q4 -- YES --&gt; C5[Adjust.]                     </pre>	
<p>Note (1) Judge if it is in the state of overload or not as follows.</p> <ul style="list-style-type: none"> <li>• Is there any short-circuit of air?</li> <li>• Isn't there any fouling or clogging on the indoor heat exchanger?</li> <li>• Is the outdoor fan control normal?</li> <li>• Isn't the room and outdoor air temperature too high?</li> </ul> <p>Note (2) For characteristics of indoor heat exchanger temperature sensor, see the error display E6.</p> <p>The graph shows a horizontal line representing indoor heat exchanger temperature. A vertical line at 56°C is labeled 'Reset'. A vertical line at 63°C is labeled 'Error stop'. The x-axis is labeled 'Indoor heat exchanger temperature (°C)'.</p>	

Note: During heating operation; After starting compressor, compressor rotation speed is decreased by detecting indoor heat exchanger temperature (Thi-R) in order to control high pressure.

Error code Remote control: E9	LED	Green	Red	Content	<b>Drain trouble</b>
	Indoor	Keeps flashing	1-time flash		
	Outdoor	Keeps flashing	Stays OFF		

<b>1. Applicable model</b>
All models

<b>2. Error detection method</b>
Float switch is activated

<b>3. Condition of error displayed</b>
If the float switch OPEN is detected for 3 seconds continuously or if float switch connector or wire is disconnected.

<b>4. Presumable cause</b>
<ul style="list-style-type: none"> <li>• Defective indoor unit control PCB</li> <li>• Float switch setting error</li> <li>• Humidifier drain motor interlock setting error</li> <li>• Option equipment setting error</li> <li>• Drain piping error</li> <li>• Defective drain pump motor</li> <li>• Disconnection of drain pump motor wiring</li> </ul>

<b>5. Troubleshooting</b>	
<b>Diagnosis</b>	<b>Countermeasure</b>
<pre> graph TD     Start[Check the error data in the remote control.] --&gt; Q1{Is there any overflow?}     Q1 -- NO --&gt; Q2{Is DC12V at CNI connector.}     Q2 -- YES --&gt; C1[Check float switch.]     Q2 -- NO --&gt; Q3{Is the CNI connected firmly?}     Q3 -- NO --&gt; C2[Defective indoor unit control PCB -&gt; Replace.]     Q3 -- YES --&gt; Q4{Is there any anomaly on the option equipment?}     Q4 -- YES --&gt; C3[Check option equipment.]     Q4 -- NO --&gt; C4[Defective indoor unit control PCB -&gt; Replace.]     Q1 -- YES --&gt; Q5{Is the humidifier connected?}     Q5 -- YES --&gt; Q6{Is the humidifier drain pump motor interlocked by the indoor unit function setting of remote control?}     Q6 -- YES --&gt; Start2[Drain motor ON from the remote control.]     Q6 -- NO --&gt; C5[Correct setting to "Humidifier drain pump motor interlock".]     Start2 --&gt; Q7{Does drain pump motor operate?}     Q7 -- YES --&gt; Q8{Is the drain piping unclogged? Is the drain pipe slope OK?}     Q8 -- YES --&gt; C6[Check drain pump motor.]     Q8 -- NO --&gt; C7[Correct.]     Q7 -- NO --&gt; Q9{Is DC12V detected at CNR connector?}     Q9 -- YES --&gt; C8[Check wiring of drain motor.]     Q9 -- NO --&gt; C9[Defective indoor unit control PCB -&gt; Replace.]     </pre>	

Note: When this error occurred at power ON, disconnection of wire or connector of the float switch is suspected. Check and correct it (or replace it, if necessary).

Error code Remote control: E10	LED	Green	Red	Content Excessive number of connected indoor units (more than 17 units) by controlling with one remote control
	Indoor	Keeps flashing	Stays OFF	
	Outdoor	Keeps flashing	Stays OFF	

<p><b>1. Applicable model</b></p> <p>All models</p>	<b>5. Troubleshooting</b>	
<p><b>2. Error detection method</b></p> <p>When it detects more than 17 of indoor units connected to one remote control</p>	<p><b>Diagnosis</b></p> <pre> graph TD     A{Are more than 17 indoor units connected to one remote control?} -- NO --&gt; B[Defective remote control -&gt; Replace.]     A -- YES --&gt; C[Reduce to 16 or less units.]             </pre>	<p><b>Countermeasure</b></p>
<p><b>3. Condition of error displayed</b></p> <p>Same as above</p>		
<p><b>4. Presumable cause</b></p> <ul style="list-style-type: none"> <li>• Excessive number of indoor units connected</li> <li>• Defective remote control</li> </ul>		

Note:



Error code Remote control: E11	LED	Green	Red	Content <b>Address setting error of indoor units</b>
	Indoor	Keeps flashing	Keeps flashing	
	Outdoor	Keeps flashing	Stays OFF	

<b>1. Applicable model</b>
All models

<b>2. Error detection method</b>
IU address has been set using the “Master IU address set” function of remote control.

<b>3. Condition of error displayed</b>
Same as above

<b>4. Presumable cause</b>
Same as above

<b>5. Troubleshooting</b>	
<b>Diagnosis</b>	<b>Countermeasure</b>
<pre> graph TD     A[E11 occurs] --&gt; B{Is "Master IU address set" function of remote control used?}     B -- YES --&gt; C[Countermeasure]     </pre>	
<p>In case the wiring is below and “Mastar IU address set” is used, E11 is appeared.</p>	
	<ul style="list-style-type: none"> <li>• In cases of RC-EX3A Menu → Service setting → IU settings → Select IU</li> <li>• In cases of RC-E5 Return address No. to “IU ...” using [ ▲ ] or [ ▼ ] button.</li> </ul>

Note:

Error code Remote control: E14	LED	Green	Red	Content <b>Communication error between master and slave indoor units</b>
	Indoor	Keeps flashing	3-time flash	
	Outdoor	Keeps flashing	Stays Off	

**1. Applicable model**  
All models

**2. Error detection method**  
When communication error between master and slave indoor units occurs

**3. Condition of error displayed**  
Same as above

**4. Presumable cause**

- Unit address setting error
- Broken remote control wire
- Defective remote control wire connection
- Defective indoor unit control PCB

**5. Troubleshooting**

Diagnosis	Countermeasure
<pre> graph TD     D1{Is it OK the unit address setting for master and slave indoor units?}     D2{Is the remote control wiring between indoor units defective?}     D3{Is it restored by resetting the power source?}          D1 -- NO --&gt; C1[Correct unit address setting.]     D1 -- YES --&gt; D2     D2 -- YES --&gt; C2[Correct wiring.]     D2 -- NO --&gt; D3     D3 -- NO --&gt; C3[Defective indoor unit control PCB -&gt; Replace.]     D3 -- YES --&gt; C4["• Malfunction by noise. • Check surrounding environment."]                     </pre>	

Note (1) Set DIP switches SW5-1 and SW5-2 as shown in the following table.  
(Factory default setting – “Master”)

		Indoor unit		
		Master	Slave-a	Slave-b
DIP switch	SW5-1	OFF	OFF	ON
	SW5-2	OFF	ON	OFF

**Note:**

Error code Remote control: E16	LED	Green	Red	Content <b>Indoor fan motor anomaly</b>
	Indoor	Keeps flashing	1-time flash	
	Outdoor	Keeps flashing	Stays OFF	

<b>1. Applicable model</b>
All models

<b>2. Error detection method</b>
Detected by rotation speed of indoor fan motor

<b>3. Condition of error displayed</b>
<ul style="list-style-type: none"> <li>When actual rotation speed of indoor fan motor drops to lower than <math>200\text{min}^{-1}</math> for 30 seconds continuously, the compressor and the indoor fan motor stop.</li> <li>After 2-seconds, it starts again automatically, but if this error occurs 4 times within 60 minutes after the initial detection.</li> </ul>

<b>4. Presumable cause</b>
<ul style="list-style-type: none"> <li>Defective indoor unit control PCB</li> <li>Foreign material at rotational area of fan propeller</li> <li>Defective fan motor</li> <li>Dust on indoor unit control PCB</li> <li>Blown fuse</li> <li>External noise, surge</li> </ul>

<b>5. Troubleshooting</b>	
<b>Diagnosis</b>	<b>Countermeasure</b>
<pre> graph TD     D1{Does any foreign material intervene in rotational area of fan propeller?} -- YES --&gt; C1[Remove foreign material.]     D1 -- NO --&gt; D2{Does the fan rotate smoothly when turned by hand?}     D2 -- YES --&gt; D3{Is DC280V detected between ①-④ of fan motor connector CNM?}     D2 -- NO --&gt; C2[Replace the fan motor.]     D3 -- YES --&gt; PR[Power source reset]     D3 -- NO --&gt; D4{Is the fuse F1 or F2 blown?}     PR --&gt; D5{Is it normalized?}     D4 -- YES --&gt; C3[Replace faulty fan motor and indoor unit control PCB.]     D4 -- NO --&gt; C4[Check power voltage.]     D5 -- YES --&gt; C5[Malfunction by temporary noise]     D5 -- NO --&gt; C6[Replace fan motor. (If the error persists after replacing the fan motor, replace the indoor unit control PCB.)]     </pre>	

Note:

Error code Remote control: E18	LED	Green	Red	Content <b>Address setting error of master and slave indoor units</b>
	Indoor	Keeps flashing	1-time flash	
	Outdoor	Keeps flashing	Stays Off	

<b>1. Applicable model</b>
All models

<b>2. Error detection method</b>
IU address has been set using the “Master IU address set” function of remote control.

<b>3. Condition of error displayed</b>
Same as above

<b>4. Presumable cause</b>
Same as above

<b>5. Troubleshooting</b>	
<b>Diagnosis</b>	<b>Countermeasure</b>
<pre> graph TD     A[E18 occurs] --&gt; B{Is "Master IU address set" function of remote control used?}     B -- YES --&gt; C[Countermeasure]             </pre>	
	<ul style="list-style-type: none"> <li>• In cases of RC-EX3A Menu → Service setting → IU settings → Select IU</li> <li>• In cases of RC-E5 Return address No. to “IU ...” using [ ▲ ] or [ ▼ ] button.</li> </ul>

Note:

Error code Remote control: E19	LED	Green	Red	Content <b>Indoor unit operation check, drain pump motor check setting error</b>
	Indoor	Keeps flashing	1-time flash	
	Outdoor	Keeps flashing	Stays OFF	

<p><b>1. Applicable model</b></p> <p>All models</p>	<b>5. Troubleshooting</b>	
<p><b>2. Error detection method</b></p> <p>After indoor operation check, when the communication between indoor and outdoor unit is established and SW7-1 is still kept ON.</p>	<p><b>Diagnosis</b></p> <pre> graph TD     Start[E19 occurs when the power ON] --&gt; Decision{Is SW7-1 on the indoor unit control PCB ON?}     Decision -- NO --&gt; Countermeasure1[Defective indoor unit control PCB (Defective SW7) -&gt; Replace.]     Decision -- YES --&gt; Countermeasure2[Turn SW7-1 on the indoor unit control PCB OFF and reset the power.]         </pre>	<p><b>Countermeasure</b></p>
<p><b>3. Condition of error displayed</b></p> <p>Same as above</p>		
<p><b>4. Presumable cause</b></p> <p>Mistake in SW7-1 setting (Due to forgetting to turn OFF SW7-1 after indoor operation check)</p>		

Note:

Error code Remote control: E20	LED	Green	Red	Content <b>Indoor fan motor rotation speed anomaly</b>
	Indoor	Keeps flashing	1-time flash	
	Outdoor	Keeps flashing	Stays OFF	

<b>1. Applicable model</b>
All models

<b>2. Error detection method</b>
Detected by rotation speed of indoor fan motor

<b>3. Condition of error displayed</b>
When the actual fan rotation speed does not reach to the speed of [required speed -50 min <sup>-1</sup> ] after 2 minutes have been elapsed since the fan motor rotation speed command was output, the unit stops by detecting indoor fan motor anomaly.

<b>4. Presumable cause</b>
<ul style="list-style-type: none"> <li>• Defective indoor unit control PCB</li> <li>• Foreign material at rotational area of fan propeller</li> <li>• Defective fan motor</li> <li>• Dust on indoor unit control PCB</li> <li>• Blown fuse</li> <li>• External noise, surge</li> </ul>

<b>5. Troubleshooting</b>	
<b>Diagnosis</b>	<b>Countermeasure</b>
<pre> graph TD     Q1{Does any foreign material intervene in rotational area of fan propeller?} -- YES --&gt; C1[Remove foreign material.]     Q1 -- NO --&gt; Q2{Does the fan rotate smoothly when turned by hand?}     Q2 -- YES --&gt; Q3{Is DC280V detected between ①-④ of fan motor connector CNM?}     Q2 -- NO --&gt; C2[Replace the fan motor.]     Q3 -- YES --&gt; R1[Power source reset]     Q3 -- NO --&gt; Q4{Is the fuse F2 blown?}     R1 --&gt; Q5{Is it normalized?}     Q4 -- YES --&gt; C3[Replace faulty fan motor and indoor unit control PCB.]     Q4 -- NO --&gt; C4[Check power voltage.]     Q5 -- YES --&gt; C5[Malfunction by temporary noise.]     Q5 -- NO --&gt; C6[Replace fan motor. (If the error persists after replacing the fan motor, replace the indoor unit control PCB.)]     </pre>	

Note:

Error code Remote control: E21	LED	Green	Red	Content <b>Defective panel switch operation</b>
	Indoor	Keeps flashing	1-time flash	

<b>1. Applicable model</b>
All models

<b>2. Error detection method</b>
Panel switch (PS) has detected Open for more than 1 second.

<b>3. Condition of Error displayed</b>
Same as above

<b>4. Presumable cause</b>
<ul style="list-style-type: none"> <li>• Defective panel switch</li> <li>• Disconnection of wiring</li> <li>• Defective indoor unit control PCB</li> </ul>

<b>5. Troubleshooting</b>				
<table border="1"> <thead> <tr> <th>Diagnosis</th> <th>Countermeasure</th> </tr> </thead> <tbody> <tr> <td> <pre> graph TD     Q1{Is grill opened?} -- YES --&gt; C1[Reset the error and close the grill.]     Q1 -- NO --&gt; Q2{Does matter improve if panel switch is turned ON forcibly after resetting error?}     Q2 -- YES --&gt; C2["Insufficient push on the panel switch at the internal face of grill -&gt; Attach 3 mm thick rubber sheet at the section where the panel switch touches the inside of grill. Close then the grill."]     Q2 -- NO --&gt; Q3{Are connectors at right inserted properly?}     Q3 -- NO --&gt; C3["Disconnected, poorly connected connectors -&gt; Reinsert properly."]     Q3 -- YES --&gt; Q4{Is there continuity between #1 - #4 of CNV on indoor unit control PCB when panel switch operation is checked?}     Q4 -- NO --&gt; C4["• Defective panel switch or incorrect panel switch wiring -&gt; Replace panel switch. • Broken wire between panel switch PCB (CNV) -&gt; Correct or replace wire."]     Q4 -- YES --&gt; C5[Defective indoor unit control PCB -&gt; Replace indoor unit control PCB.]                     </pre> </td> <td> <p>Reset the error and close the grill.</p> <p>Insufficient push on the panel switch at the internal face of grill → Attach 3 mm thick rubber sheet at the section where the panel switch touches the inside of grill. Close then the grill.</p> <p>Disconnected, poorly connected connectors → Reinsert properly.</p> <p>• Defective panel switch or incorrect panel switch wiring → Replace panel switch. • Broken wire between panel switch PCB (CNV) → Correct or replace wire.</p> <p>Defective indoor unit control PCB → Replace indoor unit control PCB.</p> </td> </tr> </tbody> </table>	Diagnosis	Countermeasure	<pre> graph TD     Q1{Is grill opened?} -- YES --&gt; C1[Reset the error and close the grill.]     Q1 -- NO --&gt; Q2{Does matter improve if panel switch is turned ON forcibly after resetting error?}     Q2 -- YES --&gt; C2["Insufficient push on the panel switch at the internal face of grill -&gt; Attach 3 mm thick rubber sheet at the section where the panel switch touches the inside of grill. Close then the grill."]     Q2 -- NO --&gt; Q3{Are connectors at right inserted properly?}     Q3 -- NO --&gt; C3["Disconnected, poorly connected connectors -&gt; Reinsert properly."]     Q3 -- YES --&gt; Q4{Is there continuity between #1 - #4 of CNV on indoor unit control PCB when panel switch operation is checked?}     Q4 -- NO --&gt; C4["• Defective panel switch or incorrect panel switch wiring -&gt; Replace panel switch. • Broken wire between panel switch PCB (CNV) -&gt; Correct or replace wire."]     Q4 -- YES --&gt; C5[Defective indoor unit control PCB -&gt; Replace indoor unit control PCB.]                     </pre>	<p>Reset the error and close the grill.</p> <p>Insufficient push on the panel switch at the internal face of grill → Attach 3 mm thick rubber sheet at the section where the panel switch touches the inside of grill. Close then the grill.</p> <p>Disconnected, poorly connected connectors → Reinsert properly.</p> <p>• Defective panel switch or incorrect panel switch wiring → Replace panel switch. • Broken wire between panel switch PCB (CNV) → Correct or replace wire.</p> <p>Defective indoor unit control PCB → Replace indoor unit control PCB.</p>
Diagnosis	Countermeasure			
<pre> graph TD     Q1{Is grill opened?} -- YES --&gt; C1[Reset the error and close the grill.]     Q1 -- NO --&gt; Q2{Does matter improve if panel switch is turned ON forcibly after resetting error?}     Q2 -- YES --&gt; C2["Insufficient push on the panel switch at the internal face of grill -&gt; Attach 3 mm thick rubber sheet at the section where the panel switch touches the inside of grill. Close then the grill."]     Q2 -- NO --&gt; Q3{Are connectors at right inserted properly?}     Q3 -- NO --&gt; C3["Disconnected, poorly connected connectors -&gt; Reinsert properly."]     Q3 -- YES --&gt; Q4{Is there continuity between #1 - #4 of CNV on indoor unit control PCB when panel switch operation is checked?}     Q4 -- NO --&gt; C4["• Defective panel switch or incorrect panel switch wiring -&gt; Replace panel switch. • Broken wire between panel switch PCB (CNV) -&gt; Correct or replace wire."]     Q4 -- YES --&gt; C5[Defective indoor unit control PCB -&gt; Replace indoor unit control PCB.]                     </pre>	<p>Reset the error and close the grill.</p> <p>Insufficient push on the panel switch at the internal face of grill → Attach 3 mm thick rubber sheet at the section where the panel switch touches the inside of grill. Close then the grill.</p> <p>Disconnected, poorly connected connectors → Reinsert properly.</p> <p>• Defective panel switch or incorrect panel switch wiring → Replace panel switch. • Broken wire between panel switch PCB (CNV) → Correct or replace wire.</p> <p>Defective indoor unit control PCB → Replace indoor unit control PCB.</p>			

Note:

Error code Remote control: E28	LED	Green	Red	Content <b>Remote control temperature sensor anomaly</b>
	Indoor	Keeps flashing	Stays OFF	
	Outdoor	Keeps flashing	Stays OFF	

**1. Applicable model**  
All models

**2. Error detection method**  
Detection of anomalously low temperature (resistance) of remote control temperature sensor (The)

**3. Condition of error displayed**  
When the temperature sensor detects -50°C or lower for 5 seconds continuously, the compressor stops. After 3-minute delay, the compressor starts again automatically, but if this error occurs again within 60 minutes after the initial detection.

**4. Presumable cause**

- Faulty connection of remote control temperature sensor
- Defective remote control temperature sensor
- Defective remote control PCB

**5. Troubleshooting**

Diagnosis	Countermeasure
<pre> graph TD     Q1{Is the remote control temperature sensor connected properly?} -- NO --&gt; C1[Correct.]     Q1 -- YES --&gt; Q2{Are the characteristics of remote control temperature sensor OK?&lt;br/&gt;Is the temperature sensor wire OK?}     Q2 -- NO --&gt; C2[Defective remote control temperature sensor -&gt; Replace.]     Q2 -- YES --&gt; C3[Defective remote control PCB -&gt; Replace. (Defective remote control temperature sensor input circuit)]                     </pre>	

Resistance-temperature characteristics of remote control temperature sensor (The)

Temperature (°C)	Resistance value (kΩ)	Temperature (°C)	Resistance value (kΩ)
0	65	30	16
1	62	32	15
2	59	34	14
4	53	36	13
6	48	38	12
8	44	40	11
10	40	42	9.9
12	36	44	9.2
14	33	46	8.5
16	30	48	7.8
18	27	50	7.3
20	25	52	6.7
22	23	54	6.3
24	21	56	5.8
26	19	58	5.4
28	18	60	5.0

**Note:** After 10 seconds has passed since remote control temperature sensor was switched from valid to invalid, E28 will not be displayed even if the sensor harness is disconnected. At same time the sensor, which is effective, is switched from remote control temperature sensor to indoor return air temperature sensor. Even though the remote control temperature sensor is set to be Effective, the return air temperature displayed on remote control for checking still shows the value detected by indoor return air temperature sensor, not by remote control temperature sensor.



Error code Remote control: E35	LED	Green	Red	Content <b>Cooling overload operation</b> (Models FDC71-250 only)
	Indoor control PCB	Keeps flashing	Stays OFF	
	Outdoor control PCB	Keeps flashing	1-time flash	
	Outdoor inverter PCB	Yellow LED Keeps flashing		

<b>1. Applicable model</b>
Models FDC71-250

<b>2. Error detection method</b>
For the error detection method, refer to the protective control by controlling compressor rotation speed and cooling high pressure protective control of micro-computer control function for corresponding models.

<b>3. Condition of error displayed</b>
When outdoor heat exchanger temperature anomaly is detected 5 times within 60 minutes or this anomalous state is detected 60 minutes continuously including compressor stop.

<b>4. Presumable cause</b>
<ul style="list-style-type: none"> <li>• Defective outdoor heat exchanger temperature sensor</li> <li>• Defective outdoor unit control (or main) PCB</li> <li>• Indoor, outdoor unit installation spaces</li> <li>• Short-circuit of air on indoor, outdoor units</li> <li>• Fouling, clogging of heat exchanger</li> <li>• Excessive refrigerant amount</li> </ul>

<b>5. Troubleshooting</b>	
<b>Diagnosis</b>	<b>Countermeasure</b>
<p style="text-align: right;">* For the characteristics of outdoor heat exchanger temperature sensor, refer to E37.</p> <pre> graph TD     Q1{Are the characteristics of outdoor heat exchanger temperature sensor normal?}     Q2{Is the unit operating in the state of cooling overload?}     Q3{Is the high pressure control normal?}     Q4{Is the temperature (measured actually) at detection of error correct?}          Q1 -- NO --&gt; C1[Replace outdoor heat exchanger temperature sensor.]     Q1 -- YES --&gt; Q2     Q2 -- YES --&gt; C2[Check unit side. • Isn't the air circulation of outdoor unit short-circuited? • Are installation spaces adequate? • Isn't there any fouling or clogging on heat exchanger?]     Q2 -- NO --&gt; Q3     Q3 -- NO --&gt; C3[Control operation check *.]     Q3 -- YES --&gt; Q4     Q4 -- NO --&gt; C4[Defective outdoor unit control (or main) PCB -&gt; Replace.]     Q4 -- YES --&gt; C5[Excessive refrigerant amount : Recharge refrigerant by weighing proper amount on a scale.]     </pre>	
<p>* For the contents of control, refer to the protective control by controlling compressor rotation speed and cooling high pressure protective control of microcomputer control function for corresponding models.</p>	

Note:

Error code Remote control: E35	LED	Green	Red	Content <b>Cooling overload operation</b> (Models FDC71-100VNP only)
	Indoor	Keeps flashing	Stays OFF	

**1. Applicable model**  
Models SRC40-60

**2. Error detection method**

Outdoor heat exchanger temperature (°C)  
Note(1) Values in ( ) are applicable when outdoor temperature (TH2) is lower than 32°C

**3. Condition of error displayed**  
When anomalous outdoor heat exchanger temperature occurs 5 times within 60 minutes or 63(56)°C or higher continues for 10 minutes, including the compressor stop.

**4. Presumable cause**

- Defective outdoor heat exchanger temperature sensor
- Defective outdoor unit PCB
- Indoor, outdoor unit installation spaces
- Short-circuit of air on indoor, outdoor units
- Fouling, clogging of heat exchanger
- Excessive refrigerant quantity

**5. Troubleshooting**

Diagnosis	Countermeasure
<p>* For the characteristics of outdoor heat exchanger temperature sensor, refer to E37.</p> <p>Are normal the characteristics of outdoor heat exchanger temperature sensor normal?</p> <p>NO →</p> <p>YES →</p> <p>Is the unit operating in the state of cooling overload?</p> <p>YES →</p> <p>NO →</p> <p>Is the high pressure control normal?</p> <p>NO →</p> <p>YES →</p> <p>Is the temperature (measured actually) at direction of error correct?</p> <p>NO →</p> <p>YES →</p>	<p>Replace outdoor heat exchanger temperature sensor.</p> <p>Check unit side.</p> <ul style="list-style-type: none"> <li>• Isn't the air circulation of outdoor unit short-circuited?</li> <li>• Are installation spaces adequate?</li> <li>• Isn't there any fouling or clogging on heat exchanger?</li> </ul> <p>Control operation check*</p> <p>Defective outdoor unit PCB → Replace.</p> <p>Excessive refrigerant amount: Recharge refrigerant by weighing proper amount on a scale.</p>

\* For the contents of control, refer to the protective control by controlling compressor rotation speed and cooling high pressure protective control of microcomputer control function for corresponding models.

Note:

Error code Remote control: E36	LED	Green	Red	Content  <b>Discharge pipe temperature error</b>
	Indoor control PCB	Keeps flashing	Stays OFF	
	Outdoor control PCB	Keeps flashing	1[5]-time flash	
	Outdoor inverter PCB	Yellow LED Keeps flashing		

Note (1) Value in [ ] is for the model FDC71VNP.

<b>1.Applicable model</b>
All models

<b>2.Error detection method</b>
For the error detection method, refer to the protective control by controlling compressor rotation speed and cooling high pressure protective control of micro-computer control function for corresponding models.

<b>3.Condition of error displayed</b>
When discharge pipe temperature anomaly is detected 2 times within 60 minutes or this anomalous state is detected 60 minutes continuously including compressor stop.

<b>4.Presumable cause</b>
<ul style="list-style-type: none"> <li>• Defective outdoor unit control (or main) PCB</li> <li>• Defective discharge pipe temperature sensor</li> <li>• Clogged filter</li> <li>• Indoor, outdoor unit installation spaces</li> <li>• Short-circuit of air on indoor, outdoor units</li> <li>• Fouling, clogging of heat exchanger</li> </ul>

<b>5.Troubleshooting</b>	
<b>Diagnosis</b>	<b>Countermeasure</b>
<pre> graph TD     D1{Are the characteristics of discharge pipe temperature sensor normal?}     D2{Is the discharge pipe temperature error persisted during cooling operation?}     D3{Is the discharge pipe temperature control normal?}     D4{Is the temperature (measured actually) at detection of error correct?}          D1 -- NO --&gt; C1[Replace discharge pipe temperature sensor.]     D1 -- YES --&gt; D2     D2 -- YES --&gt; C2[Insufficient refrigerant amount : Recharge refrigerant by weighing proper amount on a scale.]     D2 -- NO --&gt; D3     D3 -- NO --&gt; C3[Control operation check *.]     D3 -- YES --&gt; D4     D4 -- NO --&gt; C4[Defective outdoor unit control (or main) PCB -&gt; Replace.]     D4 -- YES --&gt; C5[Check unit side: • Isn't filter clogged? • Are adequate indoor, outdoor unit installation spaces? • Isn't there any short-circuit of air? • Isn't there any fouling, clogging on indoor heat exchanger?]     </pre>	
<p>* For the characteristics of discharge pipe temperature, refer to E39.</p> <p>* For the contents of control, refer to the protective control by controlling compressor rotation speed and cooling high pressure protective control of microcomputer control function for corresponding models.</p>	

Note:

Error code Remote control: E37	LED	Green	Red	Content <b>Outdoor heat exchanger temperature sensor anomaly</b>
	Indoor control PCB	Keeps flashing	Stays OFF	
	Outdoor control PCB	Keeps flashing	1-time flash	
	Outdoor inverter PCB	Yellow LED Keeps flashing		

<b>1. Applicable model</b>
All models

<b>2. Error detection method</b>
Detection of anomalously low temperature (resistance) on the outdoor heat exchanger temperature sensor

<b>3. Condition of error displayed</b>
<ul style="list-style-type: none"> <li>When the temperature sensor detects <math>-50(-55)^{\circ}\text{C}</math> or lower for 20 seconds continuously within 2 minutes to 2 minutes 20 seconds after the compressor ON, the compressor stops. After 3-minutes delay, the compressor starts again automatically, but if this anomalous temperature is detected 3 times within 40 minutes.</li> <li>When <math>-50(-55)^{\circ}\text{C}</math> or lower is detected for 5 seconds continuously within 20 seconds after compressor ON.</li> </ul> <p>Note (1) Value in ( ) are for the models FDC71-100VNP.</p>

<b>4. Presumable cause</b>
<ul style="list-style-type: none"> <li>Defective outdoor unit control (or main) PCB</li> <li>Broken sensor harness or temperature sensing section</li> <li>Disconnected wire connection (connector)</li> </ul>

<b>5. Troubleshooting</b>																	
<b>Diagnosis</b>	<b>Countermeasure</b>																
<p style="text-align: center;">Temperature-resistance characteristics</p> <p>(Broken wire) <span style="float: right;">(Short-circuit)</span></p> <table border="1"> <caption>Temperature-resistance characteristics data</caption> <thead> <tr> <th>Temperature (°C)</th> <th>Temperature sensor resistance (kΩ)</th> </tr> </thead> <tbody> <tr> <td>0</td> <td>15</td> </tr> <tr> <td>10</td> <td>10</td> </tr> <tr> <td>20</td> <td>7</td> </tr> <tr> <td>25</td> <td>5</td> </tr> <tr> <td>30</td> <td>4</td> </tr> <tr> <td>40</td> <td>3</td> </tr> <tr> <td>50</td> <td>2</td> </tr> </tbody> </table>		Temperature (°C)	Temperature sensor resistance (kΩ)	0	15	10	10	20	7	25	5	30	4	40	3	50	2
Temperature (°C)	Temperature sensor resistance (kΩ)																
0	15																
10	10																
20	7																
25	5																
30	4																
40	3																
50	2																

Note:

Error code Remote control: E38	LED	Green	Red	Content <b>Outdoor air temperature sensor anomaly</b>
	Indoor control PCB	Keeps flashing	Stays OFF	
	Outdoor control PCB	Keeps flashing	1[8]-time flash	
	Outdoor inverter PCB	Yellow LED Keeps flashing		

Note (1) Value in [ ] is for the model FDC71VNP.

<b>1.Applicable model</b>
All models

<b>2.Error detection method</b>
Detection of anomalously low temperature (resistance) on outdoor air temperature sensor

<b>3.Condition of error displayed</b>
<ul style="list-style-type: none"> <li>When the temperature sensor detects -45(-55)°C or lower for 5 seconds continuously within 2 minutes to 2 minutes 20 seconds after the compressor ON, the compressor stops. After 3-minutes delay, the compressor starts again automatically, but if this anomalous temperature is detected 3 times within 40 minutes.</li> <li>When -45(-55)°C or lower is detected for 5 seconds continuously within 20 seconds after compressor ON.</li> </ul> <p>Note (1) Value in ( ) are for the models FDC71-100VNP.</p>

<b>4.Presumable cause</b>
<ul style="list-style-type: none"> <li>Defective outdoor unit control (or main) PCB</li> <li>Broken sensor harness or temperature sensing section (Check molding.)</li> <li>Disconnected wire connection (connector)</li> </ul>

<b>5.Troubleshooting</b>	
<b>Diagnosis</b>	<b>Countermeasure</b>
<pre> graph TD     Q1{Is the outdoor air temperature sensor connector connected properly?} -- NO --&gt; C1[Correct connector.]     Q1 -- YES --&gt; Q2{Is the characteristics of the outdoor air temperature sensor OK?}     Q2 -- NO --&gt; C2[Defective outdoor air temperature sensor → Replace.]     Q2 -- YES --&gt; C3[Defective outdoor unit control (or main) PCB → Replace. (Defective outdoor air temperature sensor input circuit)]             </pre>	
<p>• <b>Models FDC71-100VNP</b></p> <p>Temperature-resistance characteristics (Broken wire)</p> <p>(Short-circuit)</p>	
<p>• <b>Models FDC71-250</b></p> <p>Temperature-resistance characteristics (Broken wire)</p> <p>(Short-circuit)</p>	

Note:

Error code Remote control: E39	LED	Green	Red	Content <b>Discharge pipe temperature sensor anomaly</b>
	Indoor control PCB	Keeps flashing	Stays OFF	
	Outdoor control PCB	Keeps flashing	1-time flash	
	Outdoor inverter PCB	Yellow LED Keeps flashing		

<b>1. Applicable model</b>
All models

<b>2. Error detection method</b>
Detection of anomalously low temperature (resistance) on the discharge pipe temperature sensor

<b>3. Condition of error displayed</b>
When the temperature sensor detects -10(-25)°C or lower for 5 seconds continuously within 10 minutes to 10 minutes 20 seconds after the compressor ON, the compressor stops. After 3-minute delay, the compressor starts again automatically, but if this anomalous temperature is detected 3 times within 40 minutes. Note (1) Value in ( ) is for the models FDC71-100VNP.

<b>4. Presumable cause</b>
<ul style="list-style-type: none"> <li>Defective outdoor unit control (or main) PCB</li> <li>Broken sensor harness or temperature sensing section (Check molding.)</li> <li>Disconnected wire connection (connector)</li> </ul>

<b>5. Troubleshooting</b>	
<b>Diagnosis</b>	<b>Countermeasure</b>
<p>• <b>Models FDC71-100VNP</b></p> <p>(Broken wire) Temperature-resistance characteristics</p>	
<p>• <b>Models FDC71-250</b></p> <p>(Broken wire) Temperature-resistance characteristics</p>	

Note:

Error code Remote control: E40	LED	Green	Red	Content <b>High pressure error (63H1 activated) (Models FDC71-250 only)</b>
	Indoor control PCB	Keeps flashing	Stays OFF	
	Outdoor control PCB	Keeps flashing	1-time flash	
	Outdoor inverter PCB	Yellow LED Keeps flashing		

<b>1. Applicable model</b>
Models FDC71-250

<b>2. Error detection method</b>
When the high pressure switch 63H1 is activated.
<p>Compressor ON</p> <p>Compressor OFF</p> <p>3.15 4.15 High pressure (MPa)</p>

<b>3. Condition of error displayed</b>
If 63H1 turns OFF (opened), the compressor stops. After 3-minute delay, the compressor restarts. If this anomaly occurs 5 times within 60 minutes or continues for 60 minutes continuously.

<b>4. Presumable cause</b>
<ul style="list-style-type: none"> <li>• Short-circuit of air flow, disturbance of air flow and clogging filter at outdoor heat exchanger/Breakdown of fan motor</li> <li>• Defective outdoor unit control (or main) PCB</li> <li>• Defective 63H1 connector</li> <li>• Defective electronic expansion valve connector</li> <li>• Closed service valve</li> <li>• Mixing of non-condensing gas (nitrogen, etc.)</li> </ul>

<b>5. Troubleshooting</b>				
<table border="1"> <thead> <tr> <th>Diagnosis</th> <th>Countermeasure</th> </tr> </thead> <tbody> <tr> <td> <p>If the power source breaker is turned OFF and ON too quickly, E40 may be displayed. (This is normal.)</p> <p>Is the service valve fully opened?</p> <p>NO → Open the service valve.</p> <p>YES</p> <p>Has 63H1 activated?</p> <p>NO → Is 63H1 connector connected properly?</p> <p>NO → Correct 63H1 connector.</p> <p>YES</p> <p>Is the electronic expansion valve connector connection OK?</p> <p>NO → Correct electronic expansion valve connector.</p> <p>YES</p> <p>If any anomaly exists on the electronic expansion valve connector connection, the power source must be reset.</p> <p>YES → Defective outdoor unit control (or main) PCB → Replace. (Defective 63H1 input circuit)</p> <p>On operation of 63H1</p> <p>1. During cooling</p> <ul style="list-style-type: none"> <li>• Is the outdoor fan motor running?</li> <li>• Isn't any short-circuit of air on the outdoor unit?</li> <li>• Are sufficient return air/supply air space secured?</li> </ul> <p>2. During heating</p> <ul style="list-style-type: none"> <li>• Isn't the indoor heat exchanger temperature sensor disconnected from the sensor casing?</li> <li>• Isn't the filter clogged?</li> </ul> <p>* Under the condition of overcharging refrigerant, 63H1 may activate due to delay of starting the preventive control by compressor speed control, because detected heat exchanger temperature, which conducts compressor speed control, becomes lower than normal condition due to excess sub-cooling degree.</p> </td> <td></td> </tr> </tbody> </table>	Diagnosis	Countermeasure	<p>If the power source breaker is turned OFF and ON too quickly, E40 may be displayed. (This is normal.)</p> <p>Is the service valve fully opened?</p> <p>NO → Open the service valve.</p> <p>YES</p> <p>Has 63H1 activated?</p> <p>NO → Is 63H1 connector connected properly?</p> <p>NO → Correct 63H1 connector.</p> <p>YES</p> <p>Is the electronic expansion valve connector connection OK?</p> <p>NO → Correct electronic expansion valve connector.</p> <p>YES</p> <p>If any anomaly exists on the electronic expansion valve connector connection, the power source must be reset.</p> <p>YES → Defective outdoor unit control (or main) PCB → Replace. (Defective 63H1 input circuit)</p> <p>On operation of 63H1</p> <p>1. During cooling</p> <ul style="list-style-type: none"> <li>• Is the outdoor fan motor running?</li> <li>• Isn't any short-circuit of air on the outdoor unit?</li> <li>• Are sufficient return air/supply air space secured?</li> </ul> <p>2. During heating</p> <ul style="list-style-type: none"> <li>• Isn't the indoor heat exchanger temperature sensor disconnected from the sensor casing?</li> <li>• Isn't the filter clogged?</li> </ul> <p>* Under the condition of overcharging refrigerant, 63H1 may activate due to delay of starting the preventive control by compressor speed control, because detected heat exchanger temperature, which conducts compressor speed control, becomes lower than normal condition due to excess sub-cooling degree.</p>	
Diagnosis	Countermeasure			
<p>If the power source breaker is turned OFF and ON too quickly, E40 may be displayed. (This is normal.)</p> <p>Is the service valve fully opened?</p> <p>NO → Open the service valve.</p> <p>YES</p> <p>Has 63H1 activated?</p> <p>NO → Is 63H1 connector connected properly?</p> <p>NO → Correct 63H1 connector.</p> <p>YES</p> <p>Is the electronic expansion valve connector connection OK?</p> <p>NO → Correct electronic expansion valve connector.</p> <p>YES</p> <p>If any anomaly exists on the electronic expansion valve connector connection, the power source must be reset.</p> <p>YES → Defective outdoor unit control (or main) PCB → Replace. (Defective 63H1 input circuit)</p> <p>On operation of 63H1</p> <p>1. During cooling</p> <ul style="list-style-type: none"> <li>• Is the outdoor fan motor running?</li> <li>• Isn't any short-circuit of air on the outdoor unit?</li> <li>• Are sufficient return air/supply air space secured?</li> </ul> <p>2. During heating</p> <ul style="list-style-type: none"> <li>• Isn't the indoor heat exchanger temperature sensor disconnected from the sensor casing?</li> <li>• Isn't the filter clogged?</li> </ul> <p>* Under the condition of overcharging refrigerant, 63H1 may activate due to delay of starting the preventive control by compressor speed control, because detected heat exchanger temperature, which conducts compressor speed control, becomes lower than normal condition due to excess sub-cooling degree.</p>				

Note: In the protective control range for compressor startup (initial startup after power ON), even if 63H1 is activated only once (63H1 turns OFF), immediately the error is displayed.

Error code Remote control: E40	LED	Green	Red	Content <b>Service valve (gas side) closing operation</b> (Models FDC71, 90VNP1 only)
	Indoor	Keeps flashing	Stays OFF	
	Outdoor	—	4-time flash <sup>(1)</sup>	

Note (1) This LED is installed on model FDC71VNP only.

<p><b>1. Applicable model</b></p> <p>Models FDV71, 90VNP1</p>	<b>5. Troubleshooting</b>		
<p><b>2. Error detection method</b></p> <p>If the inverter output current value exceeds the setting value within 80 seconds after the compressor ON in the heating mode, the compressor stops.</p>	<b>Diagnosis</b>		<b>Countermeasure</b>
<p><b>3. Condition of error displayed</b></p> <ul style="list-style-type: none"> <li>• If the output current of inverter exceeds the specifications, it makes the compressor stopping. (In heating mode)</li> <li>• After 3-minute delay, the compressor restarts, but if this anomaly occurs 2 times within 20 minutes after the initial detection.</li> </ul>			<p>Open the service valve.</p> <p>Defective outdoor unit PCB → Replace.</p> <p>Defective outdoor unit PCB → Replace.</p>
<p><b>4. Presumable cause</b></p> <ul style="list-style-type: none"> <li>• Service valve (gas side) closing</li> <li>• Defective outdoor unit PCB</li> </ul>			

Note:



Error code Remote control: E41	LED	Green	Red	Content <b>Power transistor overheat</b> (Models FDC71-140VNX, 100-140VSX only)
	Indoor control PCB	Keeps flashing	Stays OFF	
	Outdoor control PCB	Keeps flashing	1-time flash	
	Outdoor inverter PCB	Yellow LED 6-time flash		

<b>1. Applicable model</b>
Models FDC71-140VNX, 100-140VSX

<b>2. Error detection method</b>
When less than DC14V of the output voltage is detected between ② and ③ on CNI3, E41 is displayed. (See "Note" mentioned below)

<b>3. Condition of error displayed</b>
Seme as above.

<b>4. Presumable cause</b>
<ul style="list-style-type: none"> <li>• Inverter PCB anomaly</li> <li>• Outdoor fan motor anomaly</li> <li>• Outdoor unit control PCB anomaly</li> <li>• Noise filter PCB anomaly</li> </ul>

<b>5. Troubleshooting</b>	
<b>Diagnosis</b>	<b>Countermeasure</b>
<p>• <b>Single phase models (FDC71-140VNX)</b></p> <pre> graph TD     Q1{Is DC15V detected between ② and ③ on CNI3? (1)(2)}     Q2{Is DC15V detected after disconnecting outdoor fan motor? (1)}          Q1 -- YES --&gt; C1[Replace inverter PCB . If not solved, replace noise filter PCB as well.]     Q1 -- NO --&gt; N1[Note(1) Under anomalous conditions, the voltage becomes less than DC14V.]     N1 --&gt; Q2     Q2 -- YES --&gt; C2[Replace outdoor fan motor.]     Q2 -- NO --&gt; C3[Replace outdoor unit control PCB . If not solved, replace inverter PCB as well.]     </pre> <p>Note(2) How to check the voltage between ② and ③ of CNI3? ⇒See E51</p> <p>• <b>3-phase models (FDC100-140VSX)</b> E41⇒Replace inverter PCB.</p>	

Note: The "Single phase models" of inverter PAC have no function to output the signal for the power transistor overheat. However since the power source for the power transistor and the outdoor fan motor is in the same line, when the anomaly of the outdoor fan motor occurs, E41 is displayed.

Error code Remote control: E41	LED	Green	Red	Content  <b>Power transistor overheating (Models FDC200, 250VSA only)</b>
	Indoor control PCB	Keeps flashing	Stays OFF	
	Outdoor control PCB	Keeps flashing	1-time flash	
	Outdoor inverter PCB	Yellow LED 2-time flash or 8-time flash <sup>(1)</sup>		

Note (1) 8-time flash FDC250 model only.

<b>1. Applicable model</b>
Models FDC200, 250VSA

<b>2. Error detection method</b>
When anomalously high temperature is detected by power transistor.

<b>3. Condition of error displayed</b>
Anomalously high temperature of power transistor is detected 5 times within 60 minutes.

<b>4. Presumable cause</b>
<ul style="list-style-type: none"> <li>• Inverter PCB anomaly</li> <li>• Outdoor fan motor anomaly</li> <li>• Improperly fixing of power transistor to radiator fin</li> <li>• Inadequate installation space of outdoor unit</li> </ul>

<b>5. Troubleshooting</b>	
<b>Diagnosis</b>	<b>Countermeasure</b>
<pre> graph TD     Q1{Is it possible to reset the error for 10 minutes after compressor stopped?}     A1[Replace inverter PCB.]     Q2{Can error be reset?}     Q3{Is the installation space of outdoor unit enough?}     A2[Correct it.]     Q4{Is the outdoor fan running?}     A3[Replace the outdoor fan motor or the outdoor unit control PCB.]     Q5{Is the fixing of power transistor to radiator fin OK? • Fixed screw • Application of radiating silicone}     A4[Fix properly.]     Q6{Does the error recur?}     A5[Defective inverter PCB -&gt; Replace.]     A6[OK]      Q1 -- NO --&gt; A1     A1 --&gt; Q2     Q2 -- YES --&gt; A6     Q2 -- NO --&gt; A5     Q1 -- YES --&gt; Q3     Q3 -- NO --&gt; A2     A2 --&gt; Q4     Q3 -- YES --&gt; Q4     Q4 -- NO --&gt; A3     Q4 -- YES --&gt; Q5     Q5 -- NO --&gt; A4     Q5 -- YES --&gt; Q6     Q6 -- YES --&gt; A5     Q6 -- NO --&gt; A6     </pre>	

Note:

Error code Remote control: E42	LED	Green	Red	Content  <b>Current cut (1/2)</b>
	Indoor control PCB	Keeps flashing	Stays OFF	
	Outdoor control PCB	Keeps flashing	1-time flash	
	Outdoor inverter PCB	Yellow LED		
		1-time flash or 9-time flash <sup>(1)</sup>		

Note (1) 9-time flash is for the FDC250 model only. (2) The LED on outdoor unit PCB isn't installed on models FDC71-100VNP.

<b>1. Applicable model</b>
All models

<b>2. Error detection method</b>
In order to prevent from overcurrent of inverter, if the current exceeds the specifications, it makes the compressor stopping.

<b>3. Condition of error displayed</b>
<ul style="list-style-type: none"> <li>• If the output current of inverter exceeds the specifications, it makes the compressor stopping.</li> <li>• After 3-minute delay, the compressor restarts, but if this anomaly occurs 4 times within 30 minutes after the initial detection. (FDC71-250 only)</li> </ul>

<b>4. Presumable cause</b>
<ul style="list-style-type: none"> <li>• The service valves closed</li> <li>• Faulty power source</li> <li>• Insufficient refrigerant amount</li> <li>• Faulty compressor</li> <li>• Faulty power transistor module</li> </ul>

<b>5. Troubleshooting</b>	
<b>Diagnosis</b>	<b>Countermeasure</b>
<pre> graph TD     Q1{Is the power source voltage OK?} -- NO --&gt; C1[Check power source.]     Q1 -- YES --&gt; Q2{Are the service valves opened?}     Q2 -- NO --&gt; C2[Open the service valves.]     Q2 -- YES --&gt; Q3{Is the high pressure during operation OK?}     Q3 -- NO --&gt; C3[Check refrigerant amount and refrigerant circuit. *In case of transitional increase of high pressure and/or test run, several times restarting may recover it, because liquid refrigerant (migrated) in the compressor is discharged from the compressor.]     Q3 -- YES --&gt; Q4{Is the checked result of insulation resistance and resistance between terminals (1) of compressor motor OK?}     Q4 -- NO --&gt; C4[Replace compressor.]     Q4 -- YES --&gt; E[To next page.]     </pre> <p>(1) 1.154Ω or more at 20°C (Model FDC71VNX)          0.293Ω or more at 20°C (Models FDC100-140VNX)          1.172Ω or more at 20°C (Models FDC100-140VSX)          0.448Ω or more at 20°C (Models FDC100-140VNA)          1.044Ω or more at 20°C (Models FDC100-140VSA)          1.172Ω or more at 20°C (Model FDC200VSA)          0.309Ω or more at 20°C (Model FDC250VSA)          1.619Ω or more at 20°C (Model FDC71VNP)          1.154Ω or more at 20°C (Model FDC90VNP1)          0.512Ω or more at 20°C (Model FDC100VNP)</p>	

Note:

Error code Remote control: E42	LED	Green	Red	Content  <b>Current cut (2/2)</b>
	Indoor	Keeps flashing	Stays OFF	
	Outdoor control PCB	Keeps flashing	1-time flash	
	Outdoor inverter PCB	Yellow LED		
		1-time flash or 9-time flash <sup>(1)</sup>		

Note (1) 9-time flash is for the FDC250 model only. (2) The LED on outdoor unit PCB isn't installed on models FDC71-100VNP.

<p><b>1. Applicable model</b></p> <p>All models</p>	<p><b>5. Troubleshooting</b></p>	
<p><b>2. Error detection method</b></p> <p>In order to prevent from overcurrent of inverter, if the current exceeds the specifications, it makes the compressor stopping.</p>	<p style="text-align: center;"><b>Diagnosis</b></p>	<p style="text-align: center;"><b>Countermeasure</b></p>
<p><b>3. Condition of error displayed</b></p> <ul style="list-style-type: none"> <li>• If the output current of inverter exceeds the specifications, it makes the compressor stopping.</li> <li>• After 3-minute delay, the compressor restarts, but if this anomaly occurs 4 times within 30 minutes after the initial detection. (FDC71-250only)</li> </ul>		
<p><b>4. Presumable cause</b></p> <ul style="list-style-type: none"> <li>• Defective inverter (or outdoor unit main) PCB</li> <li>• Faulty power source</li> <li>• Insufficient refrigerant amount</li> <li>• Faulty compressor</li> <li>• Faulty power transistor module</li> </ul>		

Note:

Error code Remote control: E45	LED	Green	Red	Content Communication error between inverter PCB and outdoor unit control PCB (Models FDC71-140VNX, 100-140VSX, 200, 250VSA only)
	Indoor control PCB	Keeps flashing	Stays OFF	
	Outdoor control PCB	Keeps flashing	1-time flash	
	Outdoor inverter PCB	Yellow LED Keeps flashing		

**1.Applicable model**  
Models FDC71-140VNX, 100-140VSX, 200, 250VSA

**2.Error detection method**  
When the communication between inverter PCB and outdoor unit control PCB is not established.

**3. Condition of error displayed**  
Same as above.

**4.Presumable cause**

- Inverter PCB anomaly
- Anomalous connection of connector between the outdoor unit control PCB and inverter PCB
- Outdoor unit control PCB anomaly
- Outdoor fan motor anomaly

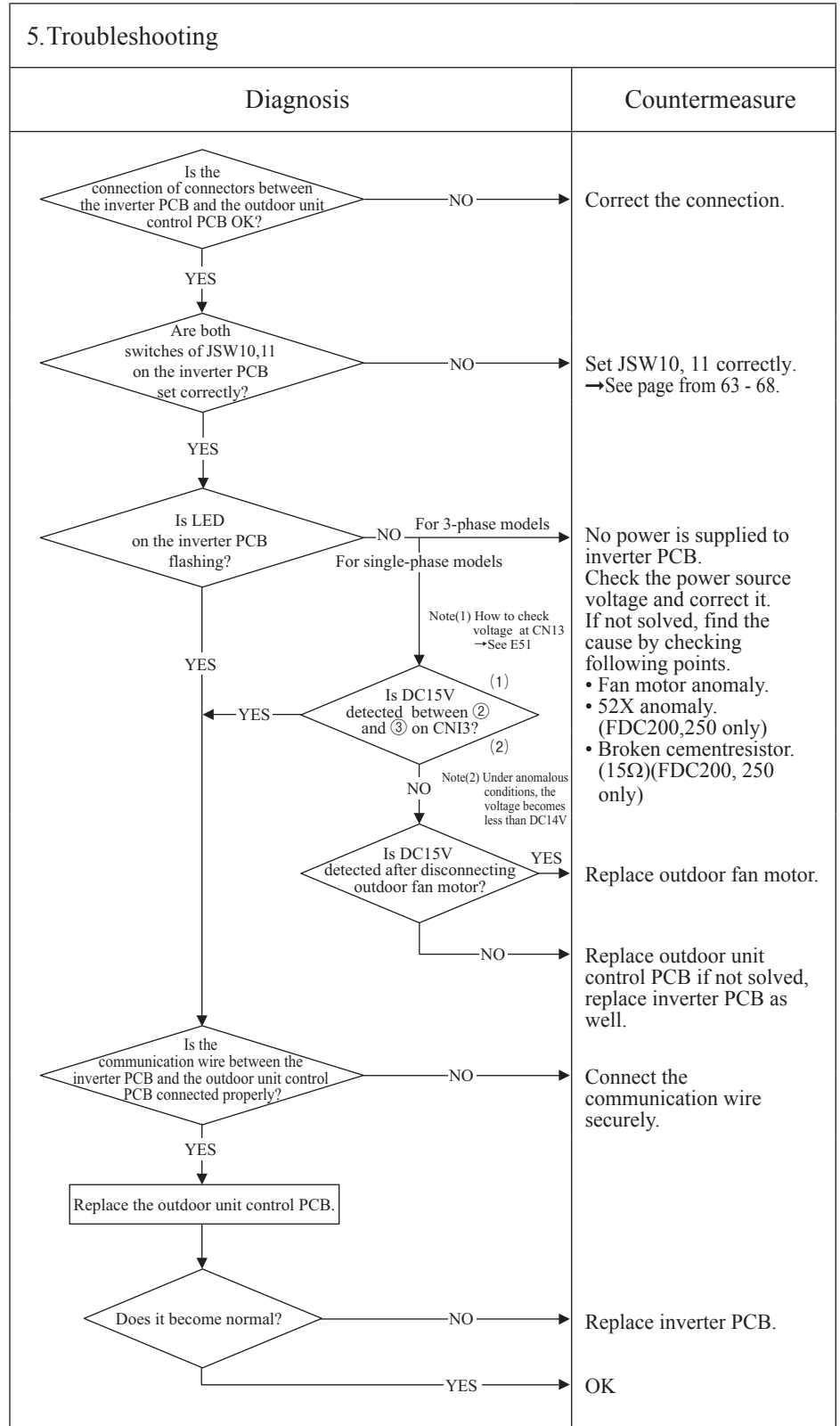

Note:

Error code Remote control: E47	LED	Green	Red	Content <b>Inverter PCB A/F module anomaly</b> (Model FDC71VNX only)
	Indoor	Keeps flashing	Stays off	
	Outdoor control PCB	Keeps flashing	1-time flash	
	Outdoor inverter PCB	Yellow LED 7-time flashing		

<b>1.Applicable model</b>
Model FDC71VNX only

<b>2.Error detection method</b>
In order to prevent from overcurrent of A/F, if the current exceeds the specifications, it makes the compressor stopping.

<b>3.Condition of error displayed</b>
• If the output current of A/F exceeds the specifications, it makes the compressor stopping.

<b>4.Presumable cause</b>
• Defective inverter PCB

<b>5.Troubleshooting</b>	
<b>Diagnosis</b>	<b>Countermeasure</b>
<pre> graph TD     Q1{Is the power source voltage OK?} -- NO --&gt; C1[Check power source.]     Q1 -- YES --&gt; Q2{Is the checked results of insulation resistance and resistance between terminals (1) of compressor motor OK? (1) 1.154Ω or more at 20°C}     Q2 -- NO --&gt; C2[Replace compressor.]     Q2 -- YES --&gt; C3[Defective outdoor inverter PCB → Replace.]             </pre>	

Note:

Error code Remote control: E47	LED	Green	Red	Content <b>Control PCB A/F module anomaly</b> (Models FDC100-140VNA only)
	Indoor	Keeps flashing	Stays OFF	
	Outdoor control PCB	Keeps flashing	1-time flash	

<b>1.Applicable model</b>
Models FDC100-140VNA

<b>2. Error detection method</b>
In order to avoid an unexpected trouble, if the protective circuit defect unexpected voltage, current and movement of the power element, it makes the compressor stopping.

<b>3. Condition of error displayed</b>
<ul style="list-style-type: none"> <li>• If the A/F anomaly occurs, it makes the compressor stopping.</li> <li>• After 3-minute delay, the compressor restarts if this anomaly occurs 4 times within 30 minutes or continues for 15 minutes continuously.</li> </ul>

<b>4. Presumable cause</b>
<ul style="list-style-type: none"> <li>• Defective control PCB</li> <li>• Defective reactor PCB</li> </ul>

<b>5. Troubleshooting</b>	
<b>Diagnosis</b>	<b>Countermeasure</b>
<pre> graph TD     D1{Is the power source voltage OK?} -- NO --&gt; C1[Check power source.]     D1 -- YES --&gt; D2{Are wires connected properly between the reactor PCB (PCB4) and the control PCB (PCB1)?}     D2 -- NO --&gt; C2[Correct wires.]     D2 -- YES --&gt; P1[Change the control PCB (PCB1)]     P1 --&gt; D3{Does it become normal?}     D3 -- NO --&gt; C3[Change the reactor PCB (PCB4) and the connection wire between the reactor PCB (PCB4) and the control PCB (PCB1).]     D3 -- YES --&gt; End(( ))             </pre>	

Note:

Error code Remote control: E47	LED	Green	Red	Content <b>Active filter voltage error</b> (Models FDC71-100VNP only)
	Indoor	Keeps flashing	Stays OFF	
	Outdoor	—	2 time flash <sup>(1)</sup>	

Note (1) This LED is installed on model FDC71VNP only.

<p><b>1. Applicable model</b></p> <p>Models FDC71-100VNP</p>	<p><b>5. Troubleshooting</b></p>	
<p><b>2. Error detection method</b></p> <p>Error is displayed if the converter voltage exceeds target voltage (3 times within 20 minutes). Remote control may be set after 3-minute delay. Error is displayed if the converter voltage is lower than DC210V (1-time within 5 seconds after power ON)</p>	<p style="text-align: center;"><b>Diagnosis</b></p> <pre> graph TD     A{Is the power source normal?} -- NO --&gt; B[Restore normal condition.]     A -- YES --&gt; C{Is voltage within the specified range?}     C -- NO --&gt; D[Restore normal condition.]     C -- YES --&gt; E{Check soldered surfaces on the outdoor unit PCB for foreign matter like dust, fouling, etc.}     E -- NO --&gt; F[Remove foreign matter like dust, fouling, etc.]     E -- YES --&gt; G[Defective outdoor unit PCB -&gt; Replace.]     </pre> <p>• If the overvoltage (DC voltage is higher than 400V) occurs, Red LED flashes 1-time.(Only model FDC71VNP)</p>	<p style="text-align: center;"><b>Countermeasure</b></p>
<p><b>3. Condition of error displayed</b></p> <p>Same as above</p>		
<p><b>4. Presumable cause</b></p> <ul style="list-style-type: none"> <li>• Defective outdoor unit PCB</li> <li>• Dust on outdoor unit PCB</li> <li>• Anomalous power source</li> </ul>		

Note:



Error code Remote control: E48	LED	Green	Red	Content <b>Outdoor fan motor anomaly</b> (Models FDC71-140VNX, 100-140VSX, 200, 250VSA only)
	Indoor control PCB	Keeps flashing	Stays OFF	
	Outdoor control PCB	Keeps flashing	1-time flash	
	Outdoor inverter PCB	Yellow LED Keeps flashing		

**1. Applicable model**  
Models FDC71-140VNX, 100-140VSX, 200, 250VSA

**2. Error detection method**  
Detected by rotation speed of outdoor fan motor

**3. Condition of error displayed**  
When actual rotation speed of outdoor fan motor (FMo1) drops to 100min<sup>-1</sup> or lower for 30 minutes continuously, the compressor and the outdoor fan motor stop. After 3-minute delay, it starts again automatically, but if this anomaly occurs 5 times within 60 minutes after the initial detection.

**4. Presumable cause**

- Defective outdoor unit control PCB
- Foreign material at rotational area of fan propeller
- Defective fan motor
- Dust on outdoor unit control PCB
- Blow fuse
- External noise, surge

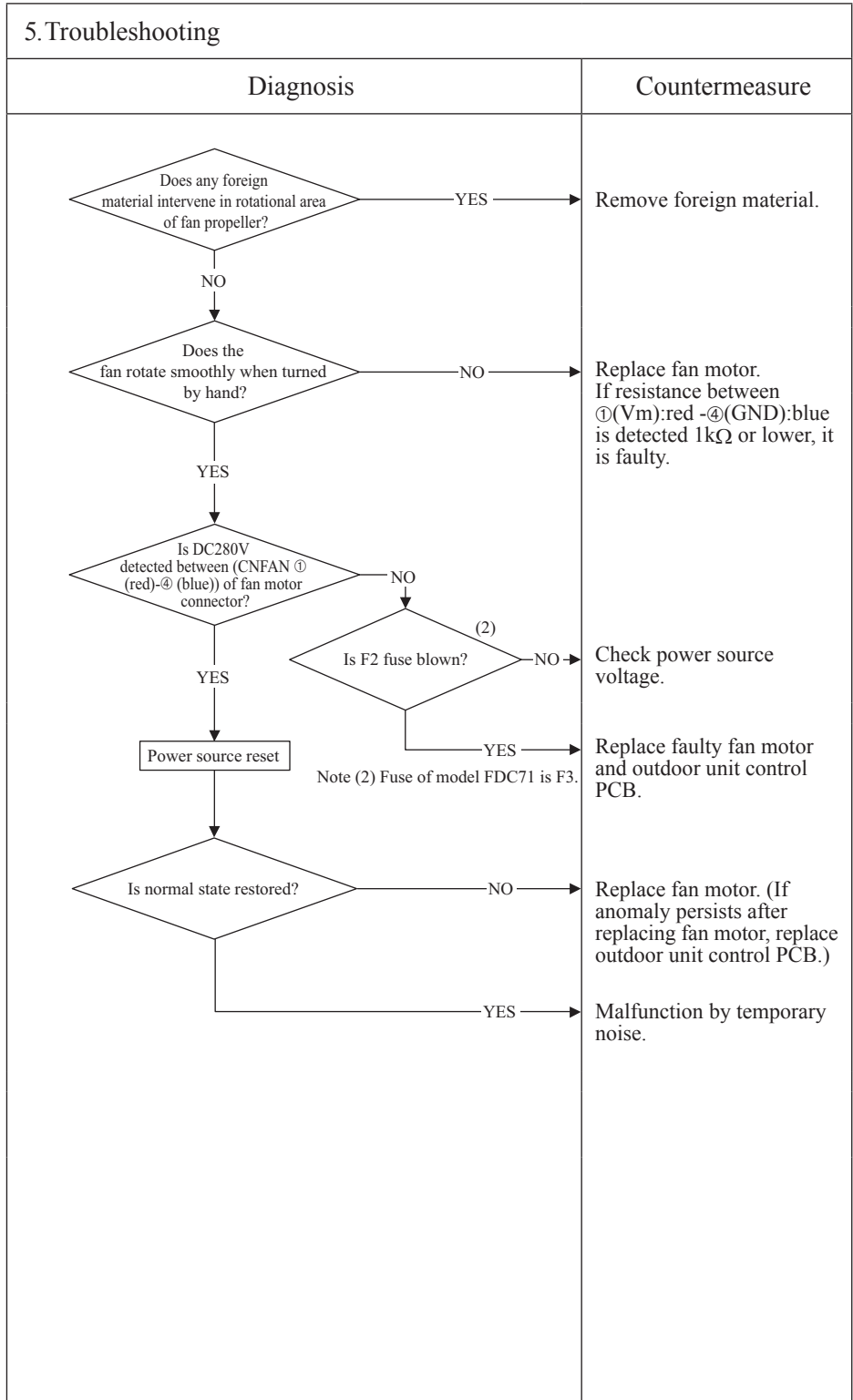

Note: When E48 error occurs, in almost cases F2 fuse (4A) [Model FDC71:F3 fuse (2A)] on the outdoor unit control PCB is blown. There are a lot of cases that fuse is blown and E48 occurs due to defective fan motor. And even though only the outdoor unit control PCB ( or fuse) is replaced, another trouble (\*1) could occur. Therefore when fuse is blown, check whether the fan motor is OK or not. After confirming the fan motor normal, check by power ON. (Don't power ON without confirming the fan motor normal.)  
\*1 The error which does not seem to relate E48 may occur like as "WAIT", Stay OFF of LED on outdoor unit control PCB, inverter communication error (E45) and etc.

Error code Remote control: E48	Indoor display	RUN light ON	TIMER light 7-time flash	Content <b>Outdoor fan motor anomaly</b> (Models FDC100-140VNA / VSA only)
	Outdoor unit control PCB	Green LED Keeps flashing	Red LED 1-time flash	
		Yellow LED Keeps flashing		
	Outdoor unit inverter PCB			

**1. Applicable model**  
Models FDC100-140VNA / VSA

**2. Error detection method**  
Detected by rotation speed of outdoor fan motor

**3. Condition of error displayed**  
When actual rotation speed of outdoor fan motor (FMo1) drops to 100min<sup>-1</sup> or lower for 30 minutes continuously, the compressor and the outdoor fan motor stop. After 3-minute delay, it starts again automatically, but if this anomaly occurs 5 times within 60 minutes after the initial detection.

- 4. Presumable cause**
- Defective outdoor unit main PCB
  - Foreign material at rotational area of fan propeller
  - Defective fan motor
  - Dust on outdoor unit main PCB
  - Blow fuse
  - External noise, surge

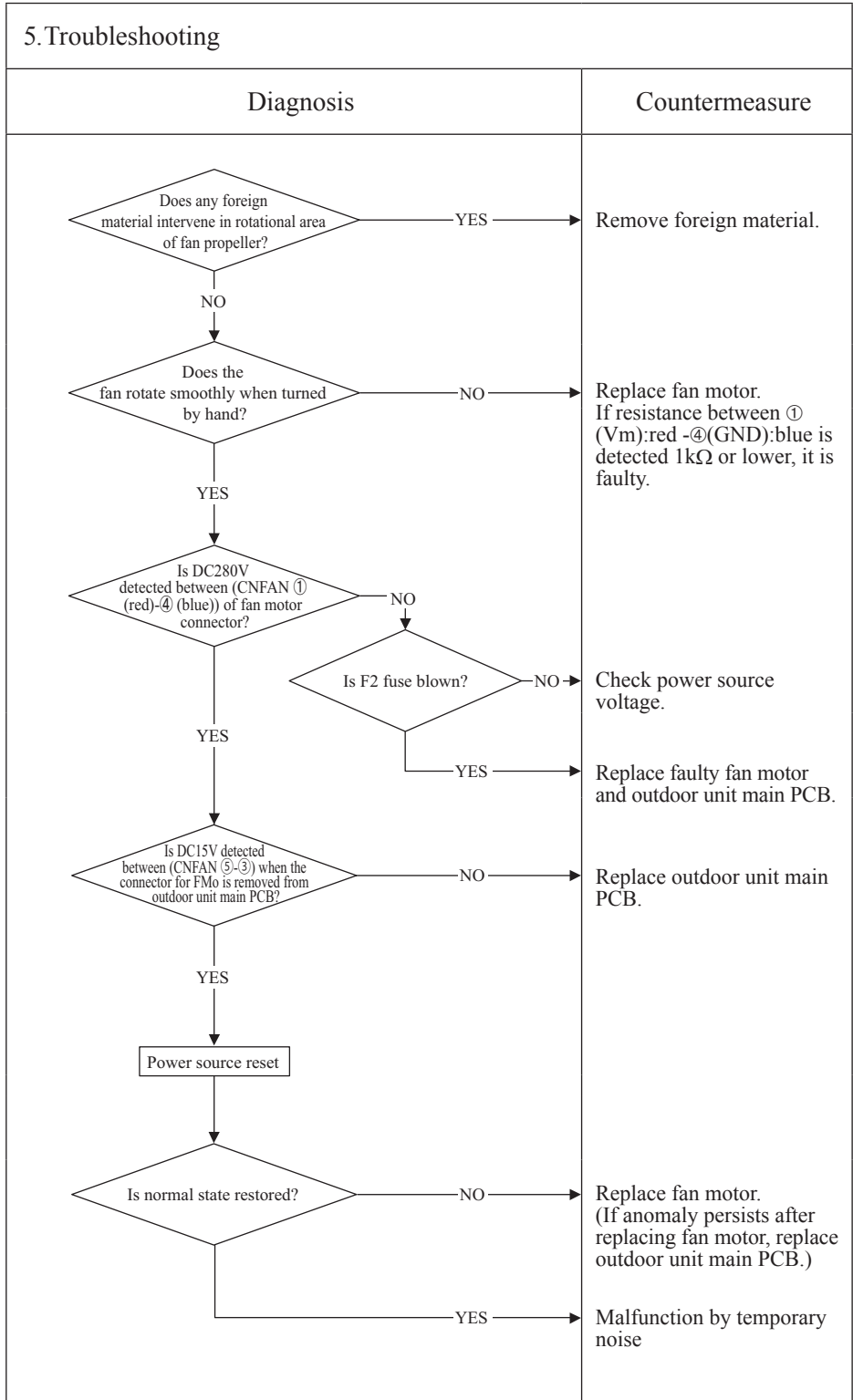

Note: When E48 error occurs, in almost cases F2 fuse (4A) on the outdoor unit main PCB is blown. There are a lot of cases that fuse is blown and E48 occurs due to defective fan motor. And even though only the outdoor unit main PCB ( or fuse) is replaced,, another trouble (\*1) could occur. Therefore when fuse is blown, check whether the fan motor is OK or not.  
After confirming the fan motor normal, check by power ON. (Don't power ON without confirming the fan motor normal.)  
\*1 The error which does not seem to relate E48 may occur like as "WAIT", Stay OFF of LED on outdoor unit control PCB, inverter communication error (E45) and etc.

Error code Remote control: E48	LED	Green	Red	Content <b>Outdoor fan motor anomaly</b> (Models FDC71-100VNP only)
	Indoor	Keeps flashing	Stays OFF	
	Outdoor	—	ON <sup>(1)</sup>	

Note (1) This LED is installed on model FDC71VNP.

<b>1. Applicable model</b>	<b>5. Troubleshooting</b>		
Models FDC71-100VNP	<b>Diagnosis</b>	<b>Countermeasure</b>	
<b>2. Error detection method</b>			
Detected by rotation speed of outdoor fan motor			
<b>3. Condition of error displayed</b>			
When actual rotation speed of outdoor fan motor drops to 75min <sup>-1</sup> or lower for 30 minutes continuously, the compressor and the outdoor fan motor stop. After 3-minute delay, it starts again automatically, but if this anomaly occurs 3 times within 60 minutes after the initial detection.			
<b>4. Presumable cause</b>	<ul style="list-style-type: none"> <li>• Defective outdoor unit PCB</li> <li>• Foreign material at rotational area of fan propeller</li> <li>• Defective fan motor</li> <li>• Dust on outdoor unit PCB</li> <li>• Blown F3 fuse</li> </ul>		

Note: When E48 error occurs, in almost cases F3 fuse (1A) on the outdoor unit PCB is blown. There are a lot of cases that fuse is blown and E48 occurs due to defective fan motor. And even though only the outdoor unit PCB ( or fuse) is replaced,, another trouble could occur. Therefore when fuse is blown, check whether the fan motor is OK or not. After confirming the fan motor normal, check by power ON. (Don't power ON without confirming the fan motor normal.)

Error code Remote control: E49	LED	Green	Red	Content <b>Low pressure error or low pressure sensor anomaly (1/2)</b> (Models FDC71-140VNX, 100-140VSX, 200, 250VSA only)
	Indoor control PCB	Keeps flashing	Stays OFF	
	Outdoor control PCB	Keeps flashing	1-time flash	
	Outdoor inverter PCB	Yellow LED Keeps flashing		

**1. Applicable model**  
Models FDC71-140VNX, 100-140VSX, 200, 250VSA

**2. Error detection method**  
Detected by low pressure drop and suction superheat

**3. Condition of error displayed**

- ① When the low pressure sensor detects 0.079MPa or lower for 15 seconds continuously, compressor stops and it restarts automatically after 3-minute delay. And if this anomaly occurs 3 times within 60 minutes.
- ② 10 minutes after the compressor starts, if the low pressure sensor detects 0.15MPa or lower for 60 minutes continuously and compressor suction superheat is detected 30degC or higher for 60 minutes continuously. And if this anomaly occurs 3 times within 60 minutes.
- ③ If low pressure sensor detects 0.079MPa or lower for 5 minutes continuously (including the compressor stop status).

**4. Presumable cause**

- Defective outdoor unit control PCB
- Defective low pressure sensor connector
- Defective low pressure sensor
- Defective suction pipe temperature sensor connector
- Defective suction pipe temperature sensor

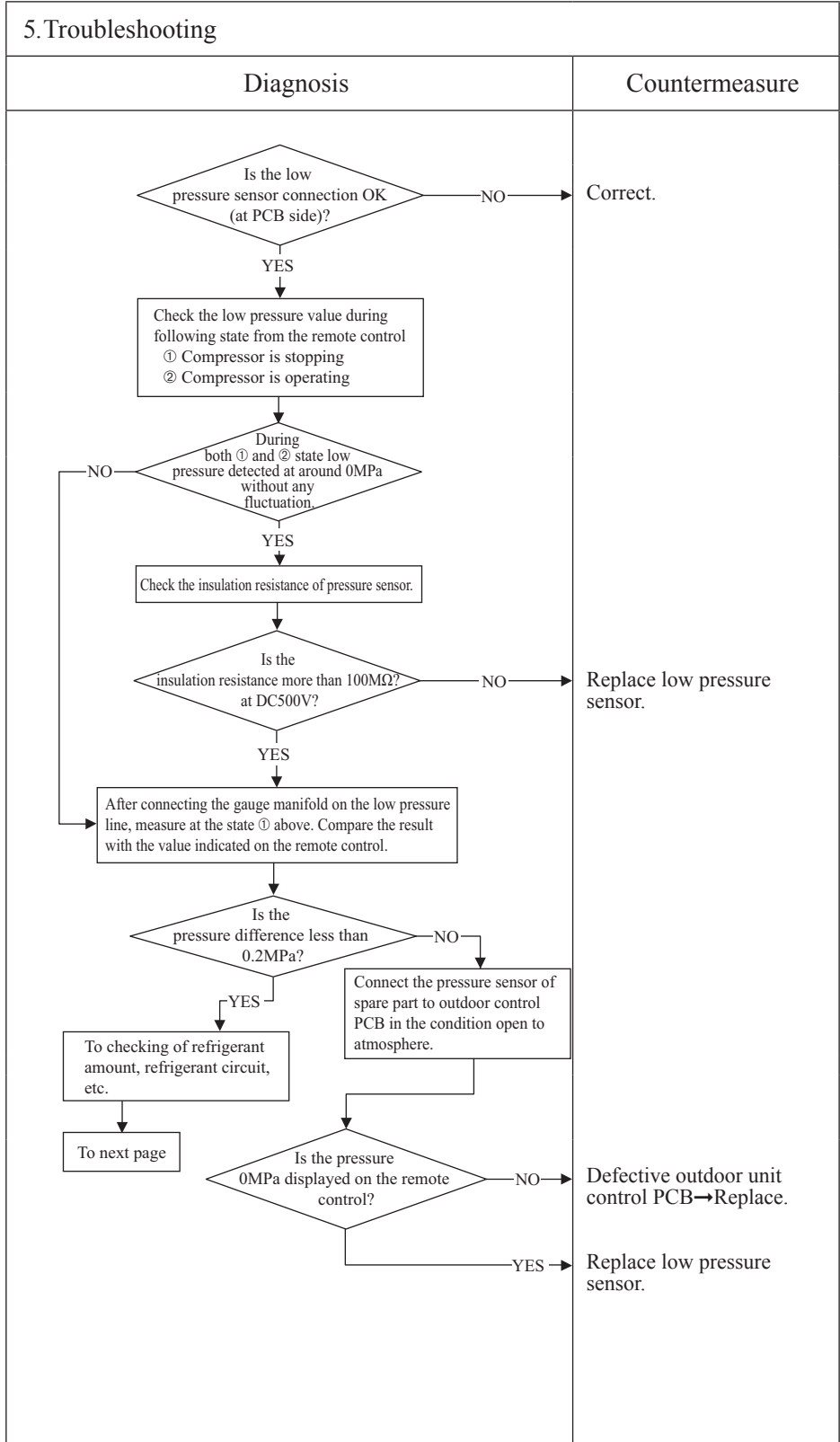

Note: \* Connect the gauge manifold to the service valve check joint during cooling, or connect it to the check joint at internal piping of outdoor unit during heating.

Error code Remote control: E49	LED	Green	Red	Content <b>Low pressure error or low pressure sensor anomaly (2/2)</b> (Models FDC71-140VNX, 100-140VSX, 200, 250VSA only)
	Indoor control PCB	Keeps flashing	Stays OFF	
	Outdoor control PCB	Keeps flashing	1-time flash	
	Outdoor inverter PCB	Yellow LED Keeps flashing		

**1.Applicable model**  
Models FDC71-140VNX, 100-140VSX, 200, 250VSA

**2.Error detection method**

**3.Condition of error displayed**

**4.Presumable cause**

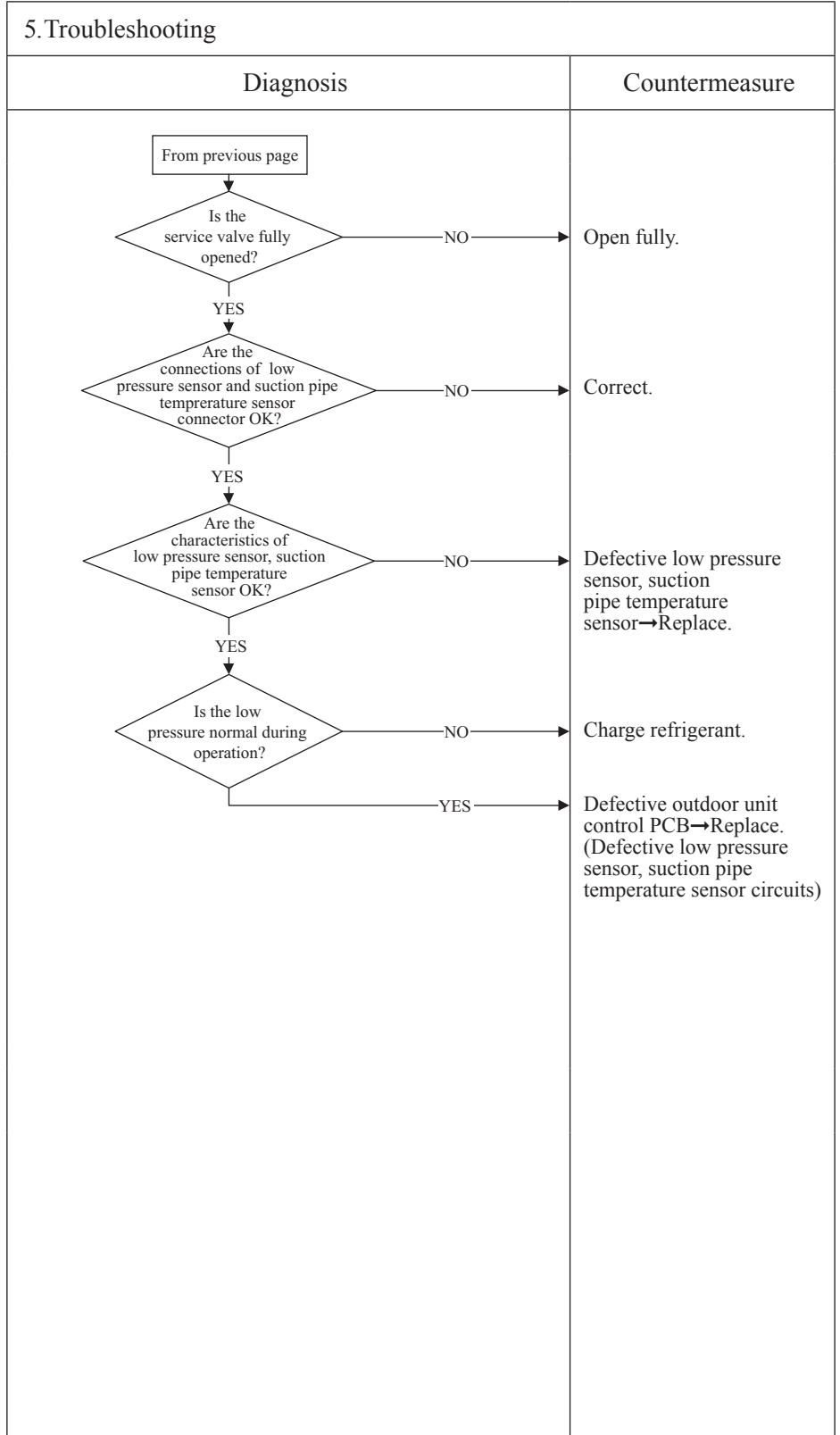

Note:

Error code Remote control: E51	LED	Green	Red	Content <b>Inverter and fan motor anomaly</b> (Models FDC71-140 only)
	Indoor control PCB	Keeps flashing	Stays OFF	
	Outdoor control PCB	Keeps flashing	1-time flash	
	Outdoor inverter PCB	Yellow LED 6-time flash		

<b>1. Applicable model</b>
Models FDC71-140

<b>2. Error detection method</b>
When power transistor anomaly is detected for 15 minutes continuously

<b>3. Condition of error displayed</b>
Same as above

<b>4. Presumable cause</b>
<ul style="list-style-type: none"> <li>• Outdoor fan motor anomaly</li> <li>• Inverter PCB anomaly</li> <li>• Outdoor unit control (or main) PCB anomaly</li> </ul>

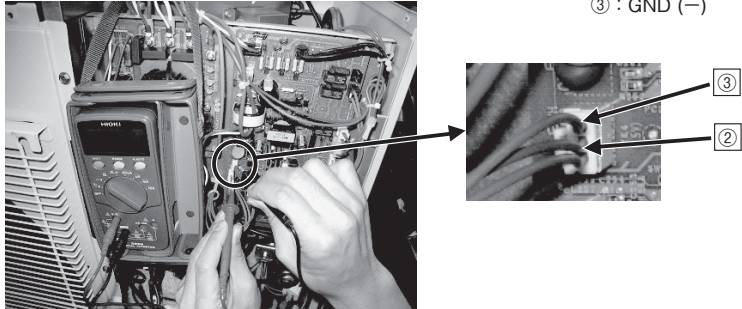
<b>5. Troubleshooting</b>	
<b>Diagnosis</b>	<b>Countermeasure</b>
<p>• <b>Models FDC71-140VNX</b></p> <p>Is DC15V (1) (2) detected between ② and ③ on CNI3?</p> <p>YES → Replace inverter PCB. If not solved, replace noise filter PCB as well.</p> <p>NO → Note(1) Under anomalous conditions, the voltage becomes less than DC14V.</p> <p>Is DC15V (1) detected after disconnecting outdoor fan motor?</p> <p>YES → Replace outdoor fan motor.</p> <p>NO → Replace outdoor unit control PCB. If not solved, replace inverter PCB as well.</p> <p>• <b>Models FDC100-140VSX</b> Replace immediately the inverter PCB and the power transistor.</p> <p>Note(2) How to check the voltage between ② and ③ of CNI3?</p>	
 <p>② : DC15V (+) ③ : GND (-)</p>	
<p>• <b>Models FDC100-140VNA/VSA</b> Replace immediately the main PCB.</p>	

Note:

Error code Remote control:E51	LED	Green	Red	Content <b>Inverter or power transistor anomaly</b> (Models FDC200, 250VSA only)
	Indoor control PCB	Keeps flashing	Stays OFF	
	Outdoor control PCB	Keeps flashing	1-time flash	
	Outdoor inverter PCB	Yellow LED 2-time flash or 8-time flash <sup>(1)</sup>		

Note (1) 8-time flash FDC250 model only.

<p><b>1.Applicable model</b></p> <p>Models FDC200, 250VSA</p>	<b>5.Troubleshooting</b>	
<p><b>2.Error detection method</b></p> <p>When power transistor anomaly is detected for 15 minutes continuously</p>	<b>Diagnosis</b>	<b>Countermeasure</b>
<p><b>3.Condition of error displayed</b></p> <p>Same as above</p>	<pre> graph TD     A[Replace inverter PCB.] --&gt; B{Did it return?}     B -- YES --&gt; C[OK]     B -- NO --&gt; D[Replace power transistor. (FDC250 model)]             </pre>	
<p><b>4.Presumable cause</b></p> <ul style="list-style-type: none"> <li>• Inverter PCB anomaly</li> <li>• Power transistor anomaly</li> </ul>		

Note:

Error code Remote control: E51	LED	Green	Red	Content <b>Power transistor anomaly</b> (Models FDC71-100VNP only)
	Indoor	Keeps flashing	Stays OFF	

<p><b>1.Applicable model</b></p> <p>Models FDC71-100VNP</p>	<b>5.Troubleshooting</b>		
<p><b>2.Error detection method</b></p> <p>Power transistor primary current</p>	<b>Diagnosis</b>		<b>Countermeasure</b>
<p><b>3.Condition of error displayed</b></p> <p>If the power transistor primary current exceeds the setting value for 3 seconds, the compressor stops.</p>	<pre> graph TD     A{Check soldered surfaces on the outdoor unit PCB for foreign matter like dust, fouling, etc.} -- NO --&gt; B[Remove foreign matter like dust, fouling, etc.]     A -- YES --&gt; C{Is F2 fuse (250V, 20A) blown?}     C -- YES --&gt; D[Replace fuse.]     C -- NO --&gt; E[Defective outdoor unit PCB -&gt; Replace.]             </pre>		<p>Remove foreign matter like dust, fouling, etc.</p> <p>Replace fuse.</p> <p>Defective outdoor unit PCB→Replace.</p>
<p><b>4.Presumable cause</b></p> <ul style="list-style-type: none"> <li>• Outdoor unit PCB anomaly</li> <li>• Dust on outdoor unit PCB</li> <li>• Blown F2 fuse</li> </ul>			

Note:



Error code Remote control: E53	LED	Green	Red	Content <b>Suction pipe temperature sensor anomaly</b> (Models FDC71-250 only)
	Indoor control PCB	Keeps flashing	Stays OFF	
	Outdoor control PCB	Keeps flashing	1-time flash	
	Outdoor inverter PCB	Yellow LED Keeps flashing		

**1.Applicable model**  
Models FDC71-250

**2.Error detection method**  
When the suction pipe temperature sensor detects anomalously low temperature

**3.Condition of error displayed**  
If the temperature sensor detects -50°C or lower for 5 seconds continuously within 10 minutes to 10 minutes 20 seconds after compressor ON, the compressor stops. When the compressor is restarted automatically after 3-minute delay, if this anomaly occurs 3 times within 40 minutes.

**4.Presumable cause**

- Defective suction pipe temperature sensor connection
- Defective suction pipe temperature sensor
- Defective outdoor unit control (or main) PCB

**5.Troubleshooting**

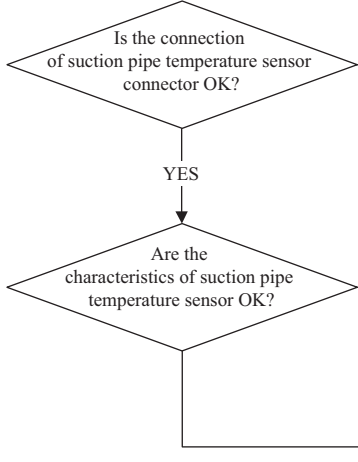
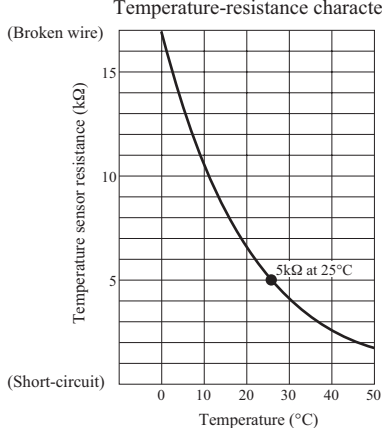
Diagnosis	Countermeasure
	<p>Correct connection of suction pipe temperature sensor connector.</p> <p>Defective suction pipe temperature sensor → Replace.</p> <p>Defective outdoor unit control (or main) PCB → Replace. (Defective suction pipe temperature sensor input circuit)</p>
<p>Temperature-resistance characteristics</p> 	

Note:

Error code Remote control: E54	LED	Green	Red	Content <b>Low pressure sensor anomaly</b> (Models FDC71-140VNX, 100-140VSX, 200, 250VSA only)
	Indoor control PCB	Keeps flashing	Stays OFF	
	Outdoor control PCB	Keeps flashing	1-time flash	
	Outdoor inverter PCB	Yellow LED Keeps flashing		

**1. Applicable model**  
Models FDC71-140VNX, 100-140VSX, 200, 250VSA

**2. Error detection method**  
When anomalous voltage (pressure) is detected

**3. Condition of error displayed**  
If the pressure sensor detects DC0V or lower and DC4.0V or higher for 5 seconds continuously within 2 minutes to 2 minutes 20 seconds after compressor ON, the compressor stops. When the compressor is restarted automatically after 3-minute delay, if this anomaly occurs 3 times within 40 minutes.

- 4. Presumable cause**
- Defective low pressure sensor connection
  - Defective low pressure sensor
  - Defective outdoor unit control PCB
  - Improper amount of refrigerant
  - Anomalous refrigeration circuit

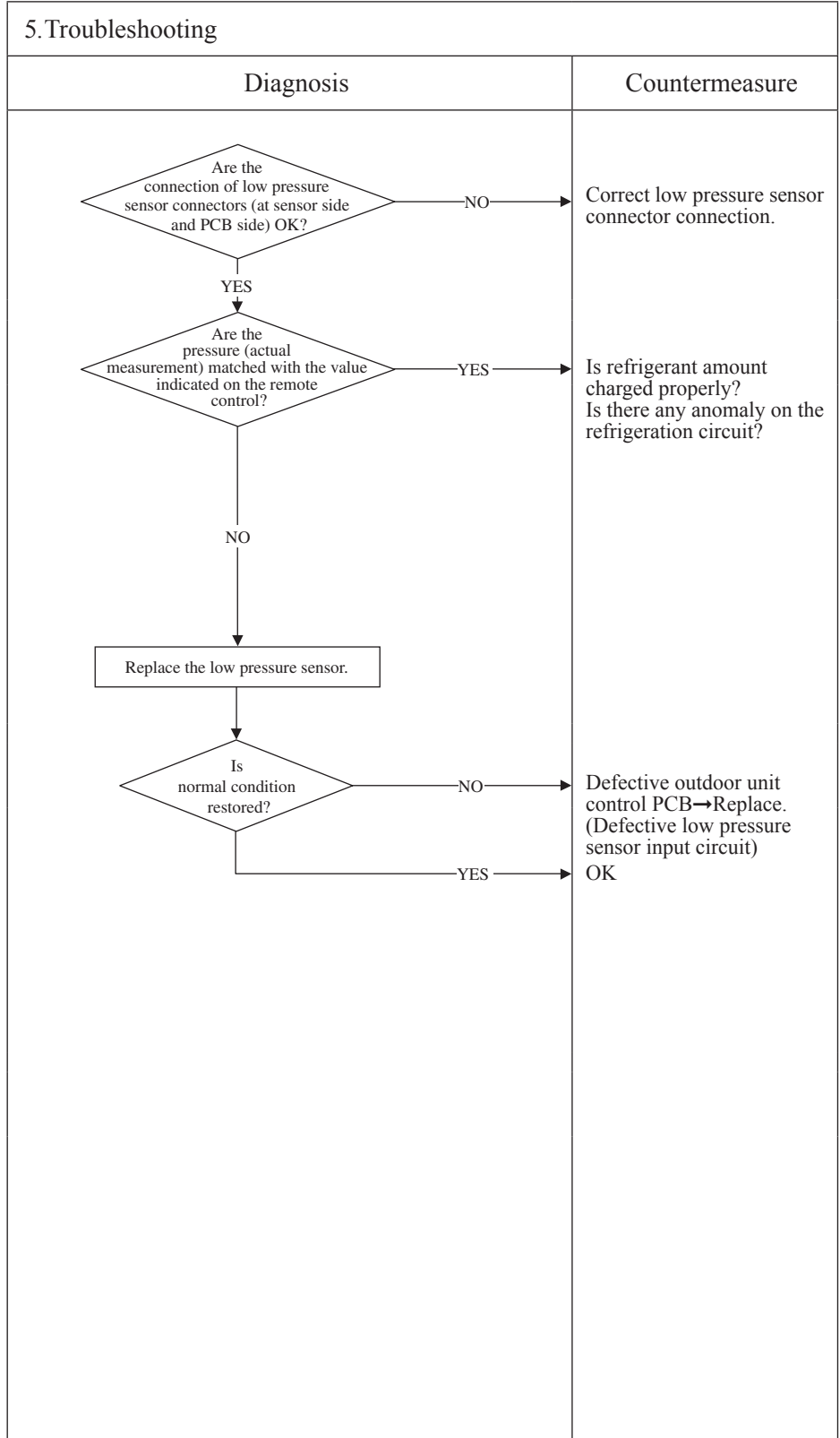

Note:

Error code Remote control:E55	LED	Green	Red	Content Compressor under dome temperature sensor anomaly (Model FDC250VSA only)
	Indoor control PCB	Keeps flashing	Stays OFF	
	Outdoor control PCB	Keeps flashing	1-time flash	
	Outdoor inverter PCB	Yellow LED Keep flashing		

1.Applicable model
Model FDC250VSA

2. Error detection method
When anomalous low temperature (resistance) is detected by the compressor under dome temperature sensor

3. Condition of error displayed
If the temperature sensor detects -50°C or lower for 5 seconds continuously within 10 minutes to 10 minutes 20 seconds after compressor ON, the compressor stops. When the compressor is restarted automatically after 3-minute delay, if this anomaly occurs 3 times within 40 minutes.

4. Presumable cause
<ul style="list-style-type: none"> <li>Defective under dome temperature sensor connection</li> <li>Defective under dome temperature sensor</li> <li>Defective outdoor unit control PCB</li> </ul>

5.Troubleshooting	
Diagnosis	Countermeasure
<pre> graph TD     A{Is the connection of under dome temperature sensor connector OK?} -- NO --&gt; B[Correct connection of under dome temperature sensor connector.]     A -- YES --&gt; C{Are the characteristics of under dome temperature sensor OK?}     C -- NO --&gt; D[Defective under dome temperature sensor -&gt; Replace.]     C -- YES --&gt; E[Replace outdoor unit control PCB. (Defective under dome temperature sensor input circuit)]             </pre>	
<p>(Broken wire)</p> <p>(Short-circuit)</p>	

Note:

Error code Remote control: E57	LED	Green	Red	Content <b>Insufficient refrigerant amount or detection of service valve closure (Models FDC71-250 only)</b>
	Indoor control PCB	Keeps flashing	Stays OFF	
	Outdoor control PCB	Keeps flashing	1-time flash	
	Outdoor inverter PCB	Yellow LED Keeps flashing		

**1.Applicable model**  
Models FDC71-250

**2.Error detection method**

- Judge insufficient refrigerant amount by detecting the temperature difference between indoor heat exchanger (Thi-R) and indoor return air (Thi-A).
- It detects at initial startup in cooling or dehumidifying mode after power ON. (In case of model FDC71 it cannot detect)

**3.Condition of error displayed**  
Anomalous stop at initial detection

**4.Presumable cause**

- Defective indoor heat exchanger temperature sensor
- Defective indoor return air temperature sensor
- Defective indoor unit control (or main) PCB
- Insufficient refrigerant amount

**5.Troubleshooting**

Diagnosis	Countermeasure
<p>Is the service valve fully opened?</p> <p>NO →</p> <p>YES ↓</p> <p>Are the connections of indoor heat exchanger and/or return air temperature sensor connectors OK?</p> <p>NO →</p> <p>YES ↓</p> <p>Are the characteristics of indoor heat exchanger and/or return air temperature sensor OK?</p> <p>NO →</p> <p>YES ↓</p> <p>Is the low pressure during operation normal?</p> <p>NO →</p> <p>YES →</p>	<p>Open fully.</p> <p>Correct indoor heat exchanger, return air temperature sensor connector connections.</p> <p>Defective indoor heat exchanger, return air temperature sensor →Replace.</p> <p>Charge refrigerant.</p> <p>Defective indoor unit control (or main) PCB→Replace. (Defective indoor heat exchanger, return air temperature sensor input circuits)</p>

Indoor heat exchanger, return air temperature sensor  
Temperature-resistance characteristics

(Broken wire)

(Short-circuit)

Note: Insufficient refrigerant amount preventive control makes compressor stopped, if it judges insufficient refrigerant amount by detecting the temperature difference between indoor heat exchanger (Thi-R) and return air temperature (Thi-A) for 1 minute after compressor ON in cooling or dehumidifying mode and for 9 minutes after compressor ON in heating mode. [ in cooling mode: (Thi-A)-(Thi-R)≤4degC, in heating mode: (Thi-R)-(Thi-A)≤4degC ]

Error code Remote control: E57	LED	Green	Red	Content <b>Insufficient refrigerant amount or detection of service valve closure (Models FDC71-100VNP only)</b>
	Indoor	Keeps flashing	Stays OFF	

<b>1. Applicable model</b>
Models FDC71-100VNP
<b>2. Error detection method</b>
<ul style="list-style-type: none"> <li>Judge insufficient refrigerant amount by detecting the temperature difference between indoor heat exchanger (Thi-R) and indoor return air (Thi-A).</li> </ul>
<b>3. Condition of error displayed</b>
When the insufficient refrigerant amount is detected 3 times within 60 minutes.
<b>4. Presumable cause</b>
<ul style="list-style-type: none"> <li>Defective indoor heat exchanger temperature sensor</li> <li>Defective indoor return air temperature sensor</li> <li>Defective indoor unit control PCB</li> <li>Insufficient refrigerant amount</li> </ul>

<b>5. Troubleshooting</b>	
<b>Diagnosis</b>	<b>Countermeasure</b>
<p style="text-align: center;">Indoor heat exchanger, return air temperature sensor Temperature-resistance characteristics</p> <p style="text-align: center;">(Broken wire)</p> <p style="text-align: center;">(Short-circuit)</p>	

Note: When the compressor speed is 50 rps or under at 5 minutes after the start of compressor or the completion of defrost operation, the low refrigerant protection control judges, by detecting the difference between the indoor heat exchanger temperature (Thi-R) and the indoor return air temperature (Thi-A), that it is in the state of gas leakage, and stops the compressor.  
 Cooling: Indoor return air temperature (Thi-A) – Indoor heat exchanger temperature (Thi-R) ≤ 4 degC  
 Heating: Indoor heat exchanger temperature (Thi-R) – Indoor return air temperature (Thi-A) ≤ 4 degC (FDC100VNP:6degC)

Error code Remote control: E58	LED	Green	Red	Content <b>Current safe stop</b> (Models FDC71-100VNP only)
	Indoor	Keeps flashing	Stays OFF	

<p><b>1.Applicable model</b></p> <p>Models FDC71-100VNP</p>	<b>5.Troubleshooting</b>		
<p><b>2.Error detection method</b></p> <p>When the current safe control has operated at the compressor speed of 30 rps or under:</p>	<b>Diagnosis</b>		<b>Countermeasure</b>
<p><b>3.Condition of error displayed</b></p> <p>Same as above</p>	<pre> graph TD     D1{Is the refrigerant amount normal?} -- NO --&gt; C1[Adjust the refrigerant amount properly.]     D1 -- YES --&gt; D2{Is outdoor ventilation condition good?}     D2 -- NO --&gt; C2[Secure space for inlet and outlet.]     D2 -- YES --&gt; D3{Inspect compressor.}     D3 -- NO --&gt; C3[Replace compressor.]     D3 -- YES --&gt; D4{Inspect outdoor air temperature sensor.}     D4 -- NO --&gt; C4[Replace sensor.]     D4 -- YES --&gt; C5[Defective outdoor unit PCB -&gt; Replace. (Defective outdoor air temperature sensor input circuit)]                     </pre>		<p>Defective outdoor unit PCB → Replace. (Defective outdoor air temperature sensor input circuit)</p>
<p><b>4.Presumable cause</b></p> <ul style="list-style-type: none"> <li>• Excessive refrigerant amount</li> <li>• Indoor, outdoor unit installation spaces</li> <li>• Faulty compressor</li> <li>• Defective outdoor air temperature sensor</li> <li>• Defective outdoor unit PCB</li> </ul>			

Note:

Error code Remote control: E58	LED	Green	Red	Content <b>Anomalous compressor by loss of synchronism</b>
	Indoor	Keeps flashing	Stays OFF	
	Outdoor	Keeps flashing	1-time flash	

<b>1.Applicable model</b>
FDC100-140VNA FDC100-140VSA FDC100-140VNA-W FDC100-140VSA-W
<b>2.Error detection method</b>
E58
<b>3.Condition of error displayed</b>
This anomaly is established 4 times within 15 minutes.
<b>4.Presumable cause</b>
<ul style="list-style-type: none"> <li>• Insufficient time elapsed after the power supplied before compressor startup. (Startup the compressor without crankcase heater ON)</li> <li>• Compressor anomaly</li> <li>• PCB anomaly</li> </ul>

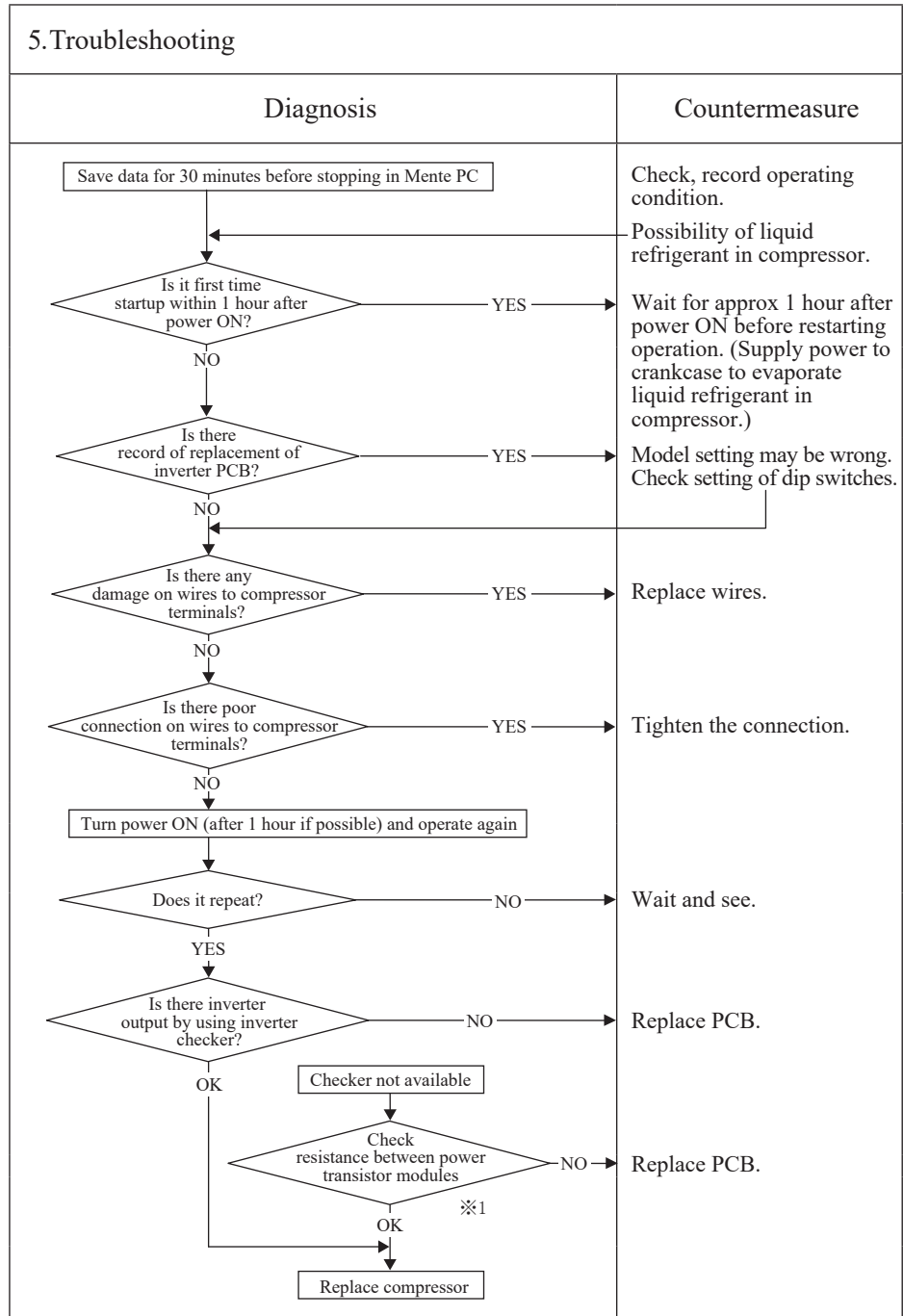

Note: 1. ※1 Measurement position: Check resistance between P-U, P-V, P-W, N-U, N-V, N-W, P-N (Disconnect wires from compressor beforehand.)

2. Measurement position to check power transistor (Refer to page 76)

Model name	P	N	U	V	W	Note
FDC100-140VNA	IC2 24 or 25 pin	IC2 18, 19 or 20 pin	U(RD) TB7	V(WH) TB8	W(BL) TB9	IC2:Power transistor
FDC100-140VNA-W						
FDC100-140VSA	T12	IC2 34, 35 or 36 pin	U(RD) TB7	V(WH) TB8	W(BL) TB9	IC2:Power transistor
FDC100-140VSA-W						

3. If it fails to repeat, connect the Mente PC, and continue to collect data.

Error code Remote control: E59	LED	Green	Red	Content <b>Compressor startup failure (1/2)</b> (Models FDC71-140VNX, 100-140VSX only)
	Indoor control PCB	Keeps flashing	Stays OFF	
	Outdoor control PCB	Keeps flashing	5-time flash	
	Outdoor inverter PCB	Yellow LED Stays OFF		

**1. Applicable model**  
Models FDC71-140VNX, 100-140VSX

**2. Error detection method**  
When it fails to change over to the operation for rotor position detection of compressor motor

**3. Condition of error displayed**  
If the compressor fails to startup for 20 times (10 patterns x2 times) continuously.

- 4. Presumable cause**
- Outdoor fan motor anomaly
  - Outdoor unit control PCB anomaly
  - Inverter PCB anomaly
  - Anomalous power source voltage
  - Insufficient or excessive refrigerant amount
  - Faulty component for refrigerant circuit
  - Compressor anomaly (Motor or bearing)

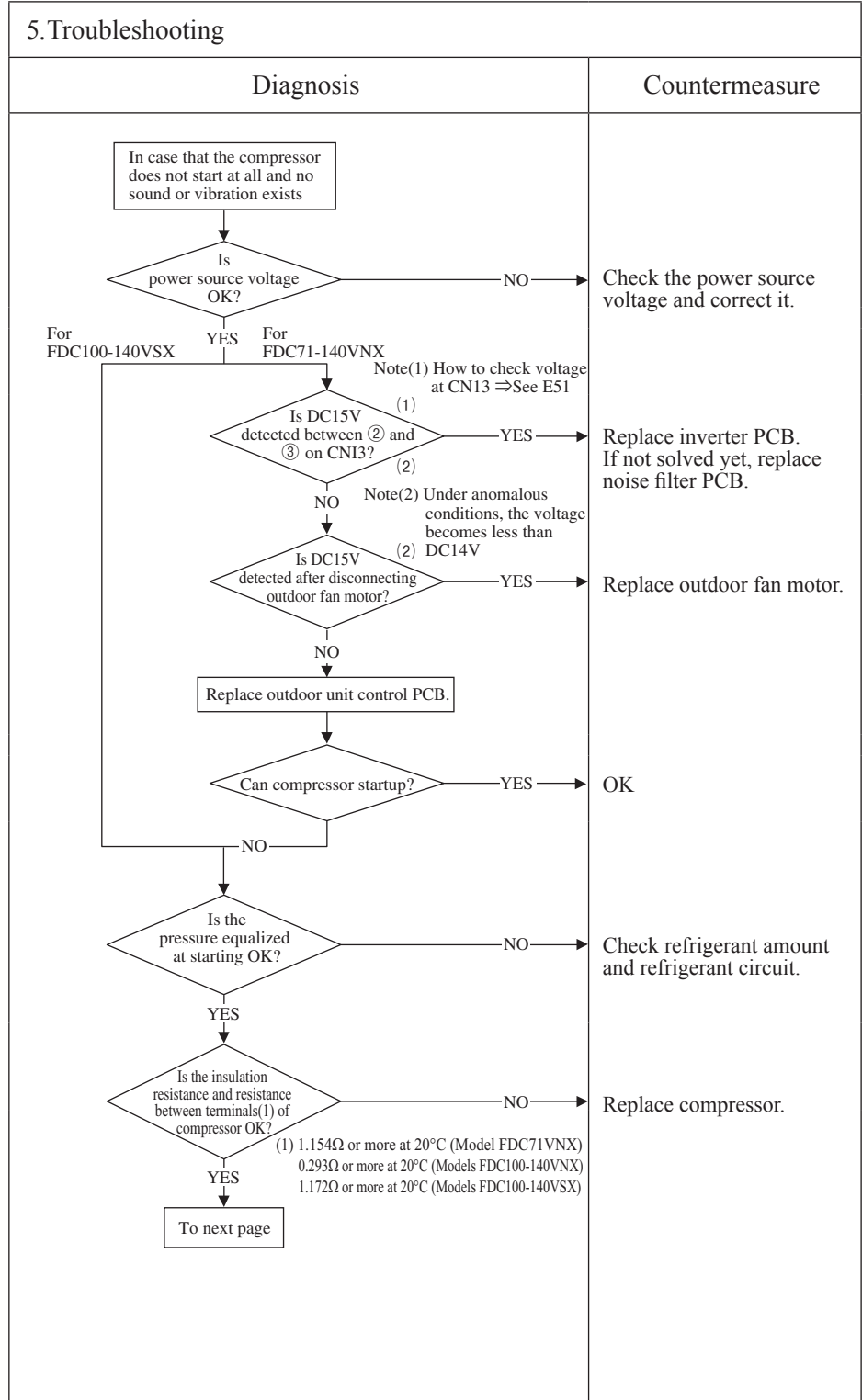

Note: Insulation resistance

- The unit is left for long period without power source or soon after installation, insulation resistance may decrease to several MΩ or lower due to the liquid refrigerant migrated in the refrigerant oil in compressor. If the electric leakage breaker is activated due to low insulation resistance, check followings.
- ① Check whether the insulation resistance can recover or not, after 6 hours has passed since power ON.  
(By energize the crankcase heater, liquid refrigerant migrated in the refrigerant oil in compressor can be evaporated)
- ② Check whether the electric leakage breaker conforms to high-harmonic specifications.  
(As inverter PAC units has inverter, in order to prevent from improper operation, be sure to use the breaker of high-harmonic type)



Error code Remote control: E59	LED	Green	Red	Content <b>Compressor startup failure (2/2)</b> (Models FDC71-140VNX, 100-140VSX only)
	Indoor control PCB	Keeps flashing	Stays OFF	
	Outdoor control PCB	Keeps flashing	5-time flash	
	Outdoor inverter PCB	Yellow LED Stays OFF		

**1. Applicable model**  
Models FDC71-140VNX, 100-140VSX

**2. Error detection method**

**3. Condition of error displayed**

**4. Presumable cause**

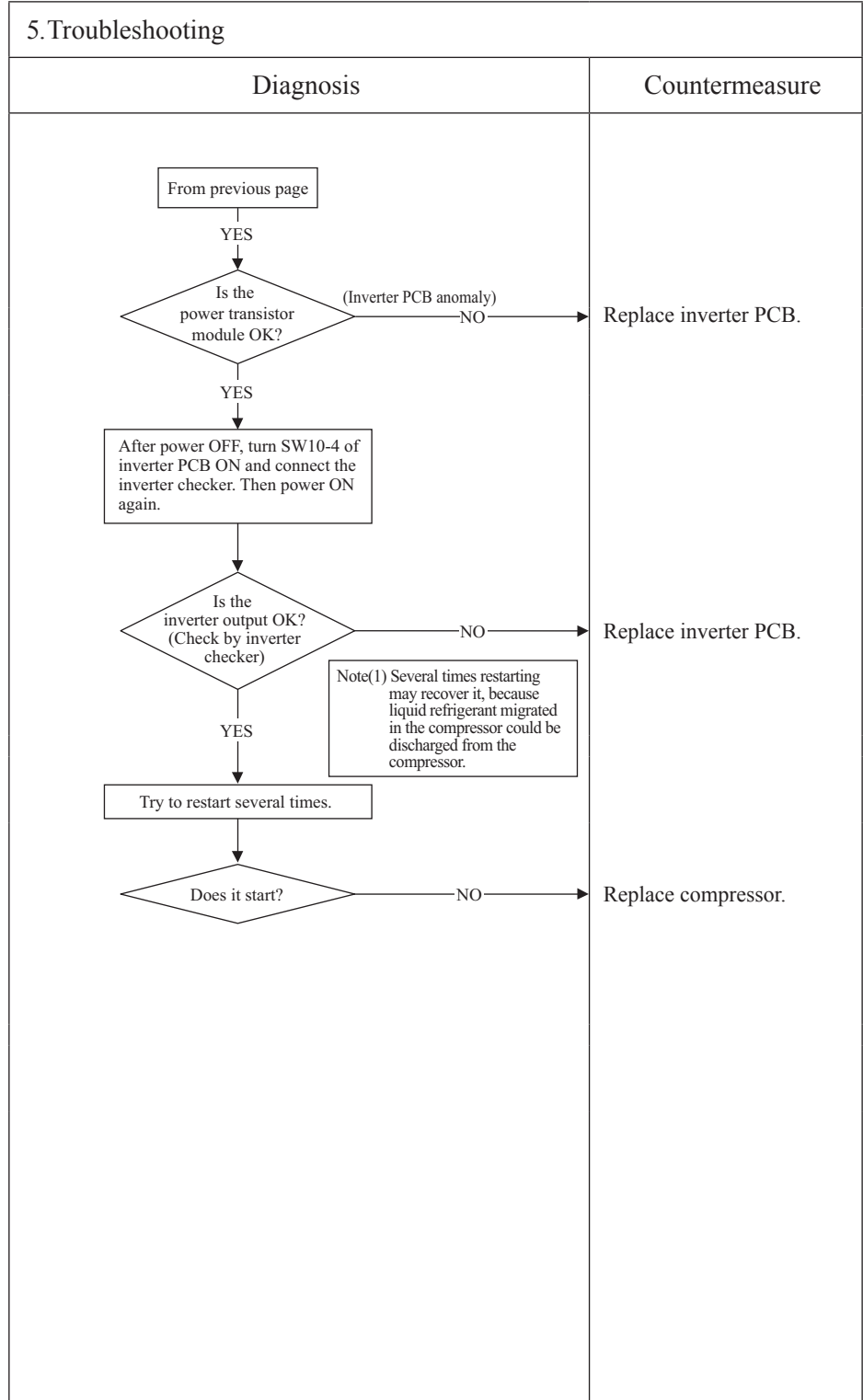

**Note:**

Error code Remote control: E59	Indoor display	RUN light	TIMER light	Content <b>Compressor startup failure (1/2)</b> (Models FDC100-140VNA/VSA only)
	Outdoor unit control PCB	Green LED	Red LED	
		Keeps flashing	5-time flash	
	Outdoor unit inverter PCB	Yellow LED		
		Stays OFF		

**1. Applicable model**  
Models FDC100-140VNA/VSA

**2. Error detection method**  
When it fails to change over to the operation for rotor position detection of compressor motor

**3. Condition of error displayed**  
If the compressor fails to startup for 20 times (10 patterns × 2 times) continuously.

- 4. Presumable cause**
- Faulty outdoor fan motor
  - Faulty outdoor unit main PCB
  - Anomalous power source voltage
  - Insufficient or excessive refrigerant amount
  - Faulty component for refrigerant circuit
  - Compressor anomaly (Motor or bearing)

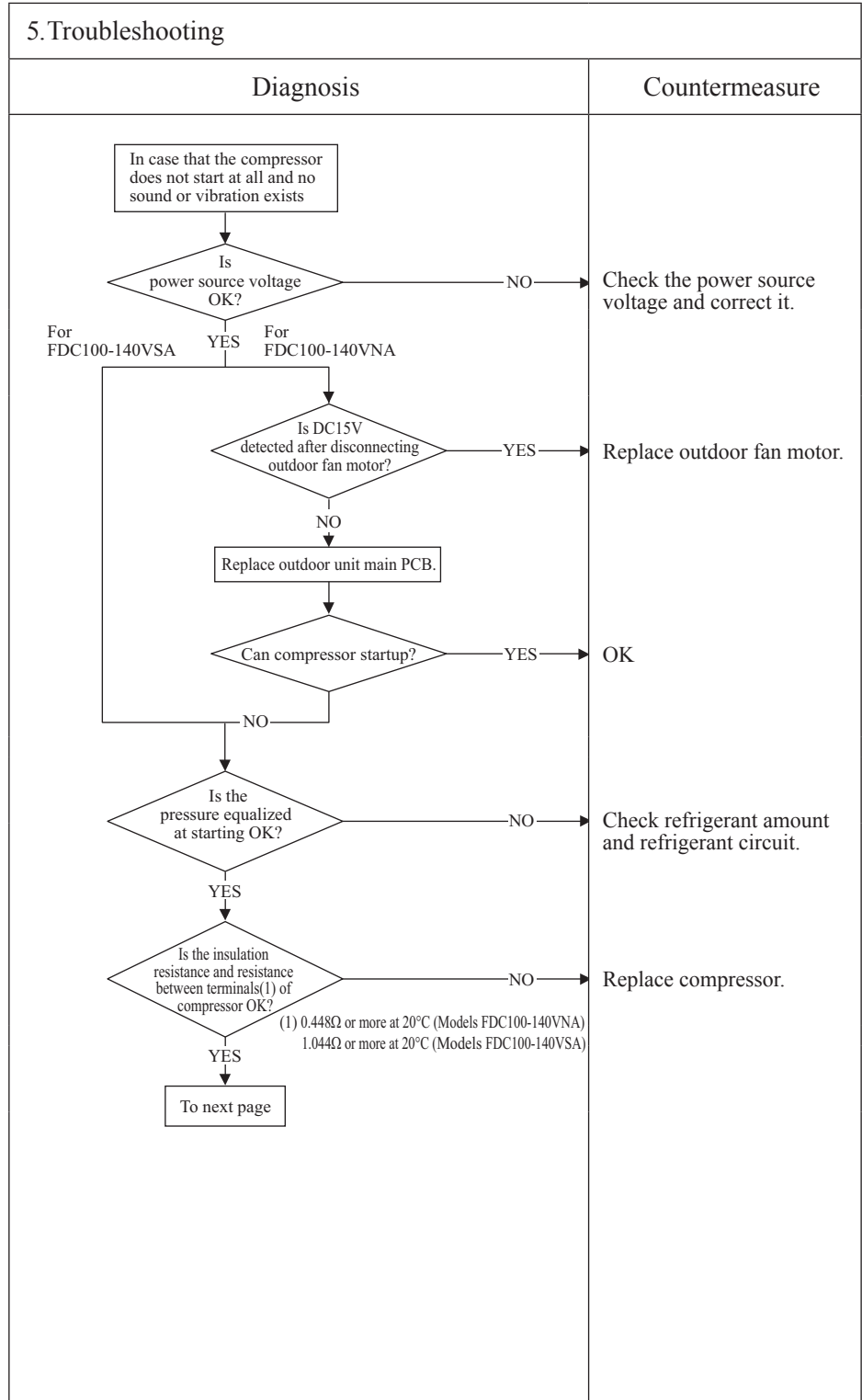

Note: Insulation resistance

- The unit is left for long period without power source or soon after installation, insulation resistance may decrease to several MΩ or lower due to the liquid refrigerant migrated in the refrigerant oil in compressor. If the electric leakage breaker is activated due to low insulation resistance, check followings.
  - ① Check whether the insulation resistance can recover or not, after 6 hours has passed since power ON.  
(By energize the crankcase heater, liquid refrigerant migrated in the refrigerant oil in compressor can be evaporated.)
  - ② Check whether the electric leakage breaker conforms to high-harmonic specifications.  
(As INVERTER PAC units has inverter, in order to prevent from improper operation, be sure to use the breaker of high-harmonic type.)

Error code Remote control: E59	Indoor display	RUN light	TIMER light	Content <b>Compressor startup failure (2/2)</b> (Models FDC100-140VNA/VSA only)
	Outdoor unit control PCB	Green LED	Red LED	
		Keeps flashing	5-time flash	
	Outdoor unit inverter PCB	Yellow LED		
Stays OFF				

**1. Applicable model**  
Models FDC100-140VNA/VSA

**2. Error detection method**

**3. Condition of error displayed**

- 4. Presumable cause**
- Faulty outdoor fan motor
  - Faulty outdoor unit main PCB
  - Anomalous power source voltage
  - Insufficient or excessive refrigerant amount
  - Faulty component for refrigerant circuit
  - Compressor anomaly (Motor or bearing)

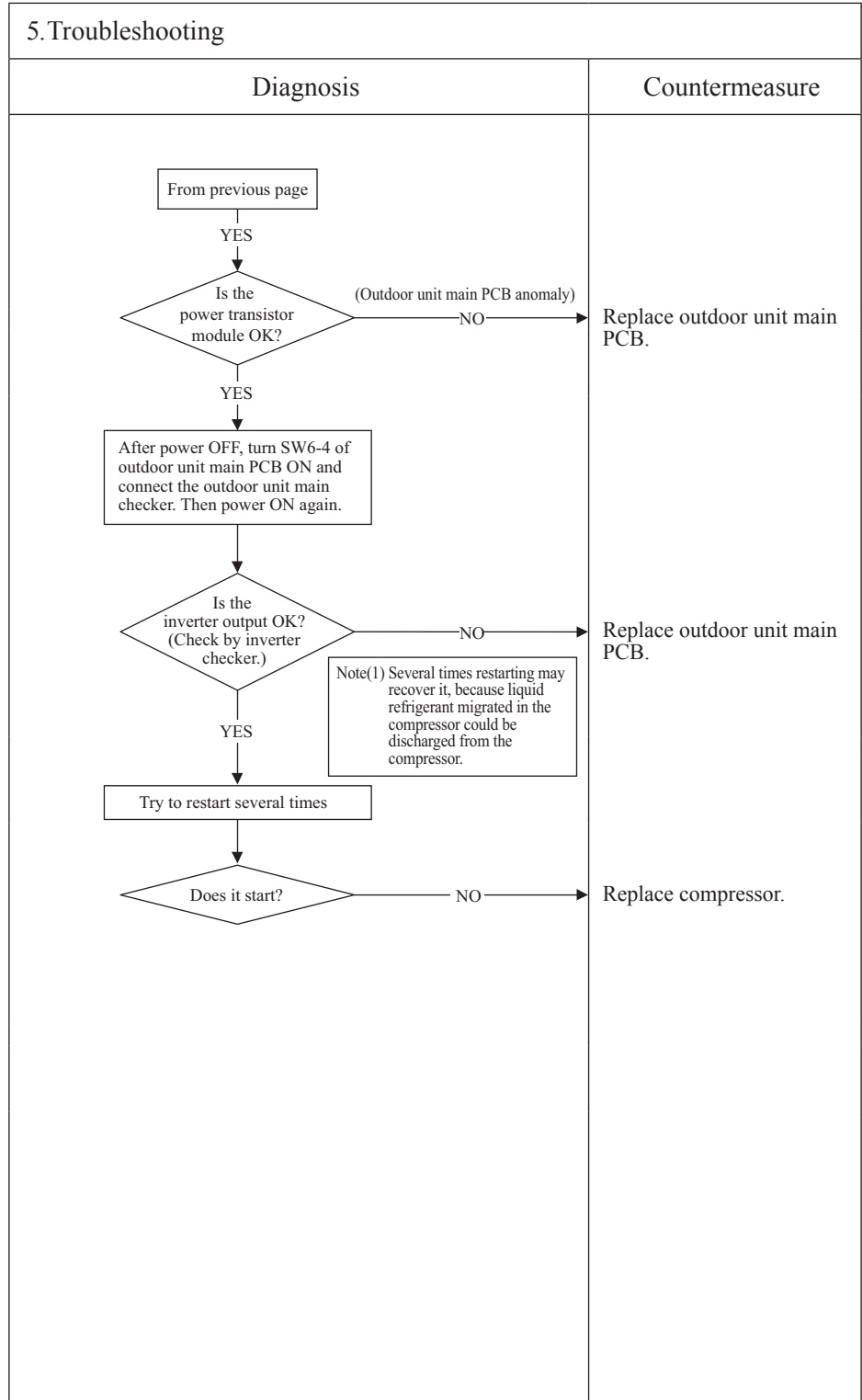

**Note:**

Error code Remote control: E59	LED	Green	Red	Content <b>Compressor startup failure (1/2)</b> (Models FDC200, 250VSA only)
	Indoor control PCB	Keeps flashing	Stays OFF	
	Outdoor control PCB	Keeps flashing	1-time flash	
	Outdoor inverter PCB	Yellow LED 4-time flash		

**1. Applicable model**  
Models FDC200, 250VSA

**2. Error detection method**  
When it fails to change over to the operation for rotor position detection of compressor motor

**3. Condition of error displayed**  
If the compressor fails to startup for 20 times (10 patterns × 2 times) continuously.

- 4. Presumable cause**
- Outdoor fan motor anomaly
  - Outdoor unit control PCB anomaly
  - Inverter PCB anomaly
  - Anomalous power source voltage
  - Insufficient or excessive refrigerant amount
  - Faulty component for refrigerant circuit
  - Compressor anomaly (Motor or bearing)

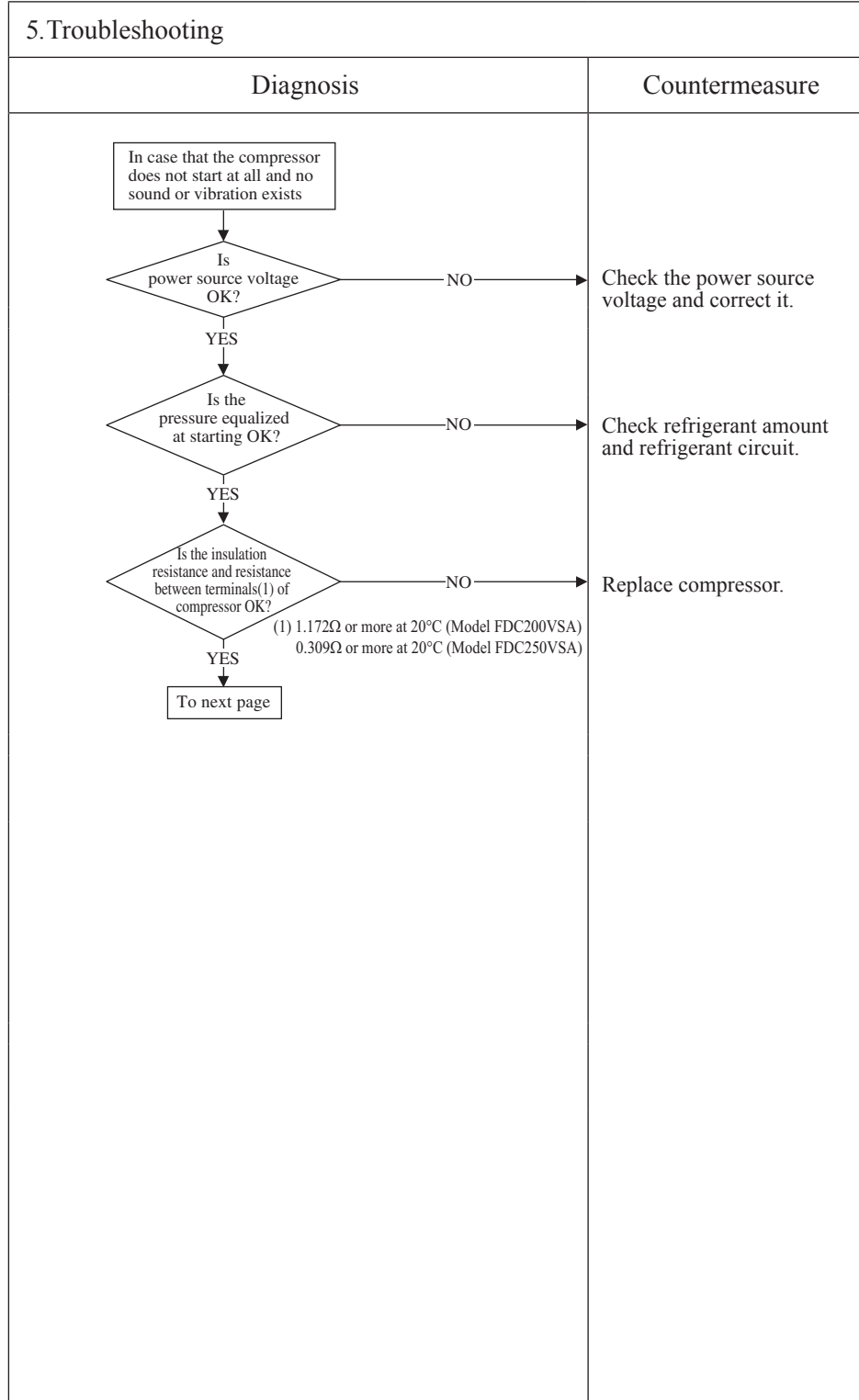

Note: Insulation resistance

- The unit is left for long period without power source or soon after installation, insulation resistance may decrease to several MΩ or lower due to the liquid refrigerant migrated in the refrigerant oil in compressor. If the electric leakage breaker is activated due to low insulation resistance, check followings.
- ① Check whether the insulation resistance can recover or not, after 6 hours has passed since power ON.  
(By energize the crankcase heater, liquid refrigerant migrated in the refrigerant oil in compressor can be evaporated.)
- ② Check whether the electric leakage breaker conforms to high-harmonic specifications.  
(As INV PAC units has inverter, in order to prevent from improper operation, be sure to use the breaker of high-harmonic type.)

Error code Remote control: E59	LED	Green	Red	Content <b>Compressor startup failure (2/2)</b> (Models FDC200, 250VSA only)
	Indoor control PCB	Keeps flashing	Stays OFF	
	Outdoor control PCB	Keeps flashing	5-time flash	
	Outdoor inverter PCB	Yellow LED 4-time flash		

**1. Applicable model**  
Models FDC200, 250VSA

**2. Error detection method**

**3. Condition of error displayed**

**4. Presumable cause**

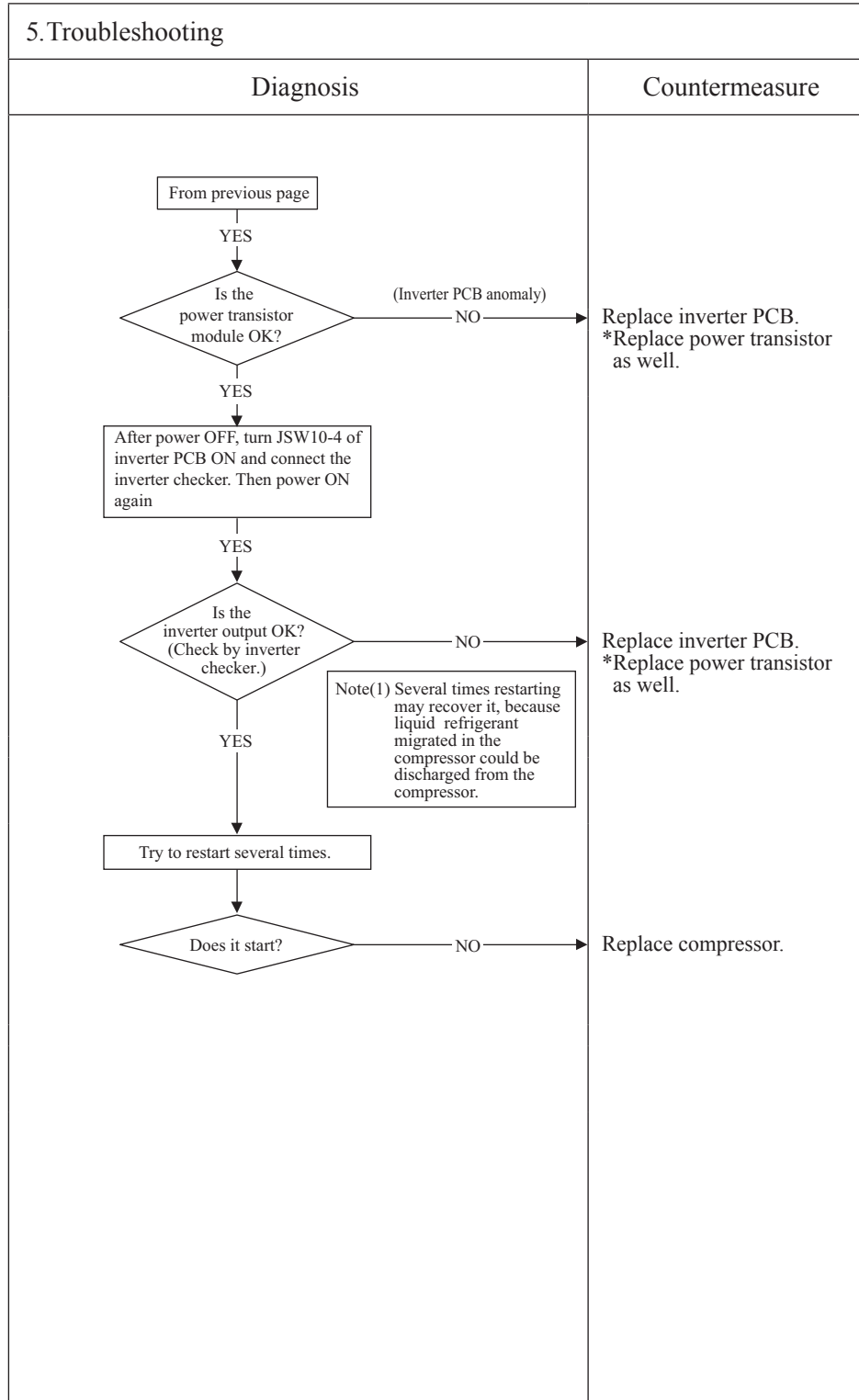

**Note:**

Error code Remote control: E59	LED	Green	Red	Content <b>Compressor startup failure</b> (Models FDC71-100VNP only)
	Indoor	Keeps flashing	Stays OFF	

Note (1) This LED is installed on models SRC40-60 only.

<p><b>1. Applicable model</b></p> <p>Models FDC71-100VNP</p>	<p><b>5. Troubleshooting</b></p> <table border="1"> <thead> <tr> <th>Diagnosis</th> <th>Countermeasure</th> </tr> </thead> <tbody> <tr> <td> <p>Compressor does not start at all. Neither noise nor vibration cannot be heard.</p> <p>Disconnect the outdoor fan motor connector and try to startup.</p> <p>Does compressor startup?</p> <p>NO</p> <p>Is power source voltage OK?</p> <p>NO</p> <p>Is the pressure balance at starting OK?</p> <p>NO</p> <p>Is the insulation resistance between terminals(1) of compressor OK ?</p> <p>(1) 1.619Ω or more at 20°C(Model FDC71VNP) 1.154Ω or more at 20°C(Model FDC90VNP1) 0.512Ω or more at 20°C(Model FDC100VNP)</p> <p>NO</p> <p>Is power transistor module OK?</p> <p>NO</p> <p>Is the output of inverter checker OK ?</p> <p>NO</p> <p>Try to startup several times</p> <p>Does it start?</p> <p>NO</p> </td> <td> <p>Replace outdoor fan motor.</p> <p>Check power source voltage.</p> <p>Check refrigerant amount and refrigerant circuit.</p> <p>Repalce compressor.</p> <p>Defective outdoor unit PCB→Replace.</p> <p>Defective outdoor unit PCB→Replace.</p> <p>Repalce compressor.</p> </td> </tr> </tbody> </table>	Diagnosis	Countermeasure	<p>Compressor does not start at all. Neither noise nor vibration cannot be heard.</p> <p>Disconnect the outdoor fan motor connector and try to startup.</p> <p>Does compressor startup?</p> <p>NO</p> <p>Is power source voltage OK?</p> <p>NO</p> <p>Is the pressure balance at starting OK?</p> <p>NO</p> <p>Is the insulation resistance between terminals(1) of compressor OK ?</p> <p>(1) 1.619Ω or more at 20°C(Model FDC71VNP) 1.154Ω or more at 20°C(Model FDC90VNP1) 0.512Ω or more at 20°C(Model FDC100VNP)</p> <p>NO</p> <p>Is power transistor module OK?</p> <p>NO</p> <p>Is the output of inverter checker OK ?</p> <p>NO</p> <p>Try to startup several times</p> <p>Does it start?</p> <p>NO</p>	<p>Replace outdoor fan motor.</p> <p>Check power source voltage.</p> <p>Check refrigerant amount and refrigerant circuit.</p> <p>Repalce compressor.</p> <p>Defective outdoor unit PCB→Replace.</p> <p>Defective outdoor unit PCB→Replace.</p> <p>Repalce compressor.</p>
Diagnosis	Countermeasure				
<p>Compressor does not start at all. Neither noise nor vibration cannot be heard.</p> <p>Disconnect the outdoor fan motor connector and try to startup.</p> <p>Does compressor startup?</p> <p>NO</p> <p>Is power source voltage OK?</p> <p>NO</p> <p>Is the pressure balance at starting OK?</p> <p>NO</p> <p>Is the insulation resistance between terminals(1) of compressor OK ?</p> <p>(1) 1.619Ω or more at 20°C(Model FDC71VNP) 1.154Ω or more at 20°C(Model FDC90VNP1) 0.512Ω or more at 20°C(Model FDC100VNP)</p> <p>NO</p> <p>Is power transistor module OK?</p> <p>NO</p> <p>Is the output of inverter checker OK ?</p> <p>NO</p> <p>Try to startup several times</p> <p>Does it start?</p> <p>NO</p>	<p>Replace outdoor fan motor.</p> <p>Check power source voltage.</p> <p>Check refrigerant amount and refrigerant circuit.</p> <p>Repalce compressor.</p> <p>Defective outdoor unit PCB→Replace.</p> <p>Defective outdoor unit PCB→Replace.</p> <p>Repalce compressor.</p>				
<p><b>2. Error detection method</b></p> <p>If it fails to change over to the rotor detection operation of compressor motor</p>					
<p><b>3. Condition of error displayed</b></p> <p>If compressor fails to startup for 42 times</p>					
<p><b>4. Presumable cause</b></p> <ul style="list-style-type: none"> <li>• Outdoor fan motor anomaly</li> <li>• Outdoor unit PCB anomaly</li> <li>• Anomalous power source voltage</li> <li>• Improper refrigerant amount and refrigerant circuit</li> <li>• Faulty compressor (Motor bearing)</li> </ul>					

**Note: Insulation resistance**

- The unit is left for long period without power source or soon after installation, migrated liquid refrigerant may dissolve in the refrigerant oil in the compressor. In such case insulation resistance decreases upto several MΩ or lower. If the electric leakage breaker is activated due to low insulation resistance, check followings.
  - ① Check whenther the insulation resistance can recover or not, after 6 hours has passed since power ON.  
(By energize the crankcase heater, migrated liquid refrigerant in the refrigerant oil in compressor can be evaporated)
  - ② Check whether the electric leakage breaker conforms to high-harmonic specifications  
(As units has inverter, in order to prevent from improper operation, be sure to use high-harmonic one.)

Error code Remote control: E60	LED	Green	Red	Content <b>Compressor rotor lock error</b> (Models FDC71-100VNP only)
	Indoor	Keeps flashing	Stays OFF	

<b>1. Applicable model</b>
Models FDC71-100VNP
<b>2. Error detection method</b>
Compressor rotor position
<b>3. Condition of error displayed</b>
If it fails again to detect the rotor position after shifting to the compressor rotor position detection operation, the compressor stops.
<b>4. Presumable cause</b>
<ul style="list-style-type: none"> <li>• Defective outdoor fan motor</li> <li>• Defective outdoor unit PCB</li> <li>• Anomalous power source voltage</li> <li>• Improper refrigerant amount and refrigerant circuit</li> <li>• Defective compressor (motor, bearing)</li> </ul>

<b>5. Troubleshooting</b>	
<b>Diagnosis</b>	<b>Countermeasure</b>
<pre> graph TD     Q1{Is the power source voltage OK?} -- NO --&gt; C1[Check and correct the power source voltage.]     Q1 -- YES --&gt; R1[Reset the power source and restart operation.]     R1 --&gt; Q2{Does the compressor start?}     Q2 -- NO --&gt; Q3{Does E59 occur?}     Q3 -- YES --&gt; C2[Correct it based on the troubleshooting of E59.]     Q3 -- NO --&gt; Q4{Does the compressor run without occurrence of E42?}     Q4 -- NO --&gt; C3[Correct it based on the troubleshooting of E42.]     Q4 -- YES --&gt; Q5{Is the output from inverter checker OK?}     Q5 -- NO --&gt; C4[Defective outdoor unit PCB → Replace.]     Q5 -- YES --&gt; Q6{Is the noise or vibration of compressor normal?}     Q6 -- NO --&gt; C5[Replace compressor.]     Q6 -- YES --&gt; Q7{Does it start up normally without recurrence of E60?}     Q7 -- NO --&gt; C6[Check compressor for insulation, resistance. Replace compressor if necessary.]     Q7 -- YES --&gt; C7[Defective outdoor unit PCB → Replace.]                     </pre>	

Note: Insulation resistance

- The unit is left for long period without power source or soon after installation, migrated liquid refrigerant may dissolve in the refrigerant oil in the compressor. In such case insulation resistance decreases upto several MΩ or lower. If the electric leakage breaker is activated due to low insulation resistance, check followings.
  - ① Check whether the insulation resistance can recover or not, after 6 hours has passed since power ON.  
(By energize the crankcase heater, migrated liquid refrigerant in the refrigerant oil in compressor can be evaporated.)
  - ② Check whether the electric leakage breaker conforms to high-harmonic specifications.  
(As units has inverter, in order to prevent from improper operation, be sure to use high-harmonic one.)

# 1.3 ELECTRICAL WIRING

## (1) Indoor units

Models FDT71VH, 100VH, 125VH, 140VH

Meaning of marks

Item	Description
AM1-4	Draft prevention function motor
CNB-Z	Connector
DM	Drain pump motor
F1,2	Fuse
FMi	Fan motor
FS	Float switch
HS	Humidity sensor
L	Reactor
LED-2	Indication lamp (Green-Normal operation)
LED-3	Indication lamp (Red-Inspection)
LM1-4	Lower motor
PIS	Motion sensor
SW2	Remote control communication address
SW5	Plural units Master / Slave setting
SW6	Model capacity setting
SW7-1	Operation check, drain pump motor test run
TB1	Terminal block ( Power source ) ( □ mark )
TB2	Terminal block ( Signal line ) ( □ mark )
ThC	Temperature sensor ( Remote control )
Th-A	Temperature sensor ( Return air )
Th-R1,2,3	Temperature sensor ( Heat exchanger )

Color marks

Mark	Color	Mark	Color
BK	Black	WH	White
BL	Blue	YE	Yellow
BR	Brown	GY	Gray
OR	Orange	YE / GN	Yellow / Green
RD	Red		

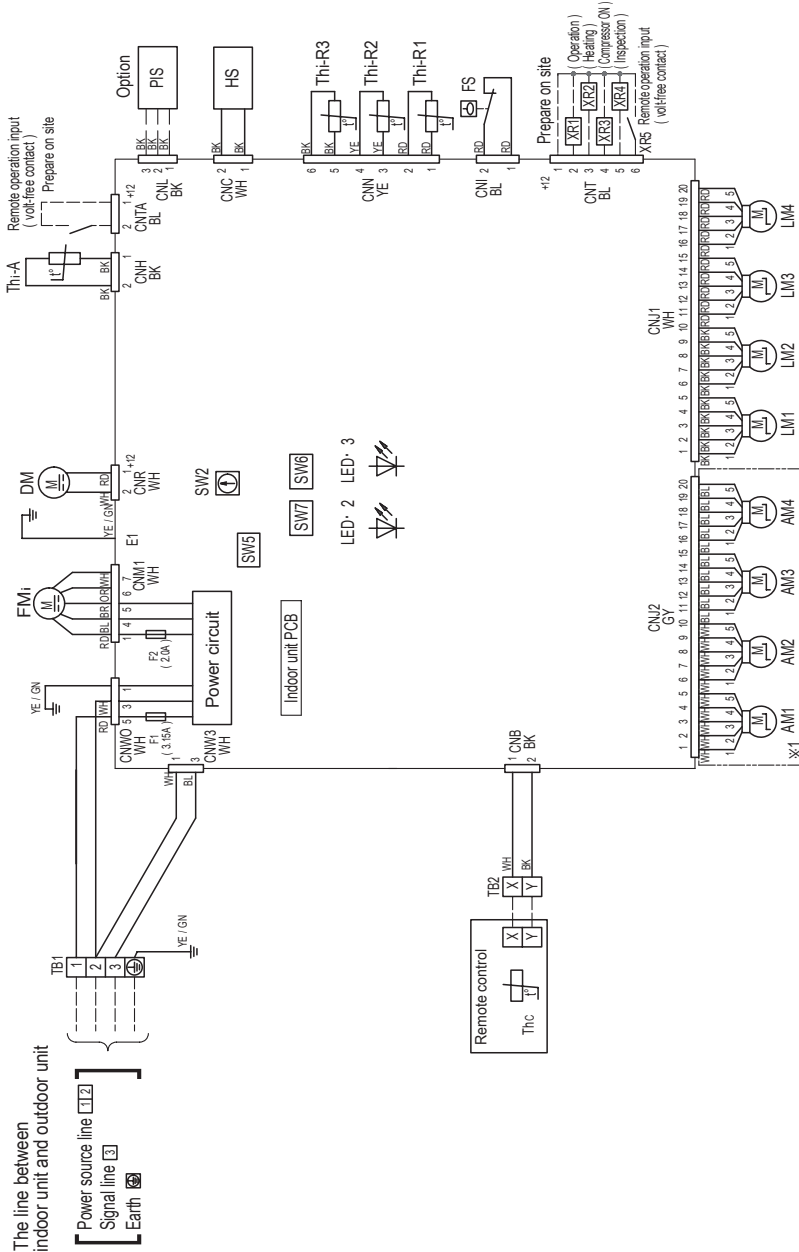

- Notes
1. — indicates wiring on site.
  2. See the wiring diagram of outside unit about the line between indoor unit and outdoor unit.
  3. Use twin core cord ( 0.3mm<sup>2</sup> ) at remote control line.  
See spec sheet of remote control in case that the total length is more than 100m.
  4. Do not put remote control line alongside power source line.
  5. Section 1 ( ※1 ) is provided on the panel T-PSAE-5AW-E only.

PJF000Z554



(2) Outdoor units  
Model FDC71VNX

Meaning of marks

Item	Description
CM	Compressor motor
FM01	Fan motor
CH	Crankcase heater
DH	Drain pan heater
52X1	Auxiliary relay (for CH)
52X3	Auxiliary relay (for 2OS)
52X4	Auxiliary relay (for DH)
2OS	Solenoid valve for 4-way valve
SM1	Expansion valve for cooling
SM2	Expansion valve for heating
63H1	High pressure switch
Tho-A	Temperature sensor (Outdoor air)
Tho-D	Temperature sensor (Discharge pipe)
Tho-R1R2	Temperature sensor (Heat exchanger)
Tho-S	Temperature sensor (Suction pipe)
Tho-IPM	Temperature sensor (IPM)
LPT	Low pressure sensor
IPM	Intelligent power module
TB	Terminal block
FF3	Fuse
CnA-Z	Connector
SW9	Pump down switch
SW3.5	Local setting switch
LED1	Indication lamp (GREEN)
LED2	Indication lamp (RED)
L1	Reactor

Color marks

Mark	Color
BK	Black
BL	Blue
BR	Brown
OR	Orange
RD	Red
WH	White
YE	Yellow
YE/GN	Yellow/Green
GY	Gray
PK	Pink

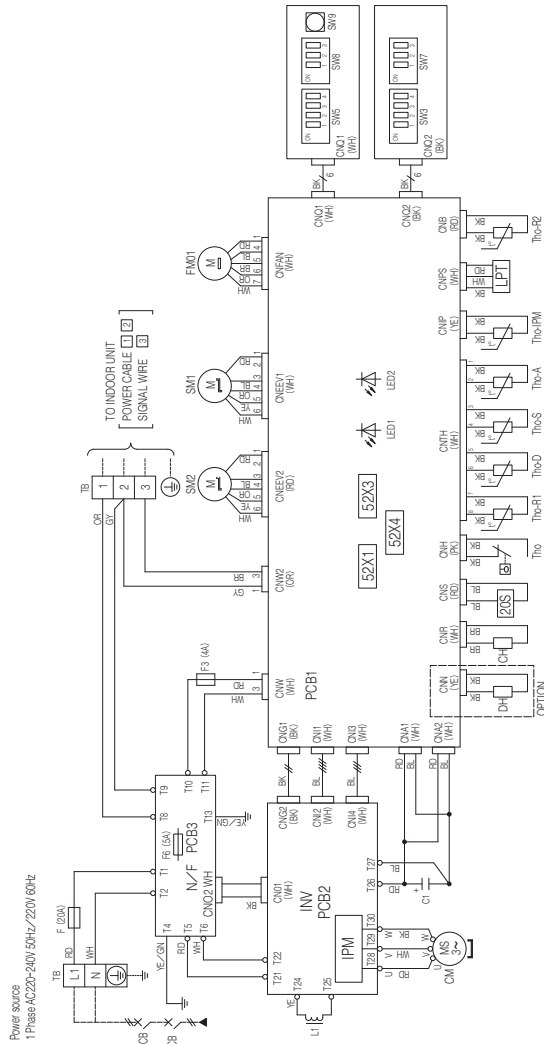

Local setting switch SW5 (Set up at shipment OFF)

SW5-1	Defrost control change	The defrost operation interval becomes shorter by turning ON this switch. This switch should be turned ON in the area where outside temperature becomes below the freezing point.
SW5-2	Snow guard fan control	When this switch is turned ON, the outdoor unit fan will run for 10 seconds in 10 minutes, when outdoor temperature falls to 3°C or lower and the compressor is not running when the unit is used in a very snowy country, set this switch to ON.
SW5-3,4	Trial operation	Method of trial operation 1. Trial operation can be performed by using SW5-3. 2. Cooling trial operation will be performed when SW5-4 is OFF, and heating trial operation when SW5-4 is ON. 3. Be sure to turn OFF SW5-3 after the trial operation is finished.

Power cable, indoor-outdoor connecting wires

Model	MAX over current (A)	Power cable size (mm <sup>2</sup> )	Power cable length (m)	Indoor-outdoor wire size x number	Earth wire size
FDC71	17	3.5	21	φ 1.6mm x 3	φ 1.6mm

- The specifications shown in the above table are for units without heaters. For units with heaters, refer to the installation instructions or the construction instructions of the indoor unit.
- Switching gear of circuit breaker capacity which is calculated from MAX. over current should be chosen along the regulations in each country.
- The cable specifications are based on the assumption that a metal or plastic conduit is used with no more than three cables contained in a conduit and a voltage drop is 2%. For an installation falling outside of these conditions, please follow the internal cabling regulations. Adapt it to the regulation in effect in each country.
- Don't operate SW3-3, SW5-1, SW5-2, SW7, SW8

PCA001Z605

Models FDC100VNX, 125VNX, 140VNX

Mark	Color	Item	Description
BK	Black	Con-Z	Connector
BL	Blue	CH	Crankcase heater
BR	Brown	DH	Drain pan heater
GN	Green	CM	Compressor motor
GR	Gray	CT	Current sensor
P	Pink	DM	Diode module
OR	Orange	F	Fuse
RD	Red	FM01	Fan motor
WH	White	IPM	Intelligent power module
Y	Yellow	L	Reactor
Y/GN	Yellow/Green	LED1	Indication lamp (GREEN)
		LED2	Indication lamp (RED)
		LPT	Low pressure sensor
		SM1	Expansion valve for cooling
		SM2	Expansion valve for heating
		SW1	Pump down switch
		SW3.5	Local setting switch
		TB	Terminal block
		Tho-A	Temperature sensor (Outdoor air)
		Tho-D	Temperature sensor (Discharge pipe)
		Tho-P	Temperature sensor (IPM)
		Tho-R1,2	Temperature sensor (Heat exchanger pipe)
		Tho-S	Temperature sensor (Suction pipe)
		20S	Solenoid valve for 4-way valve
		52X1	Auxiliary relay (for CH)
		52X2	Auxiliary relay (for DH)
		52X3	Auxiliary relay (for 20S)
		63H1	High pressure switch

Mark	Color
BK	Black
BL	Blue
BR	Brown
GN	Green
GR	Gray
P	Pink
OR	Orange
RD	Red
WH	White
Y	Yellow
Y/GN	Yellow/Green

Coormarks

Meaning of marks

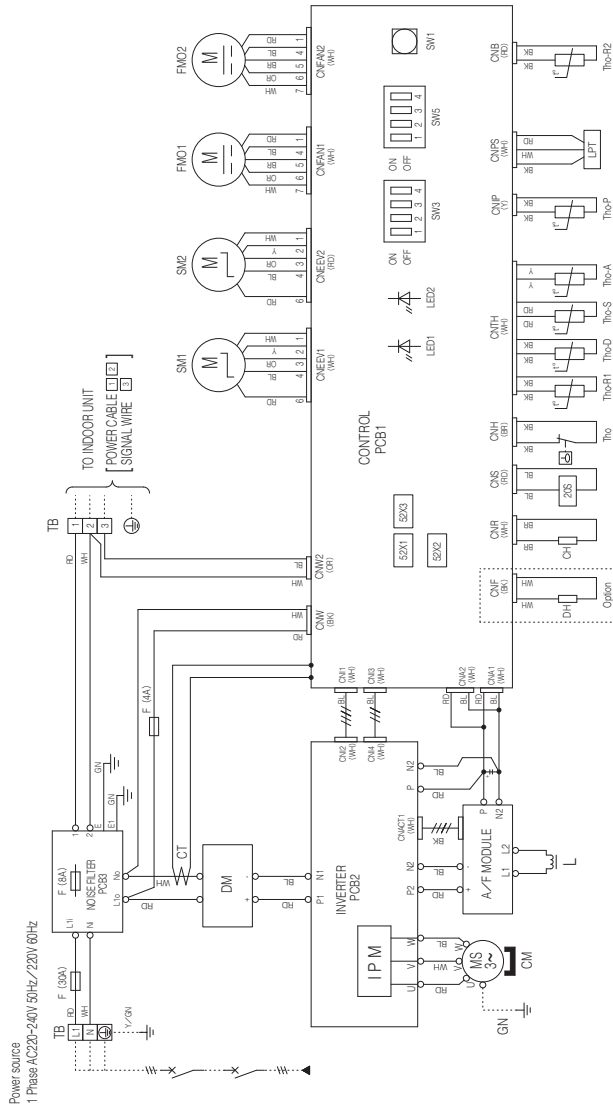

Power cable, indoor-outdoor connecting wires

Model	MAX over current (A)	Power cable size (mm <sup>2</sup> )	Power cable length (m)	Indoor-outdoor wire size x number	Earth wire size (mm)
FDC100	24	5.5	25	φ1.6mm x 3	φ1.6
FDC125	26		23		

- The specifications shown in the above table are for units without heaters. For units with heaters, refer to the installation instructions or the construction instructions of the indoor unit.
- Switchgear or circuit breaker capacity which is calculated from MAX. over current should be chosen along the regulations in each country.
- The cable specifications are based on the assumption that a metal or plastic conduit is used with no more than three cables contained in a conduit and a voltage drop is 2%. For an installation falling outside of these conditions, please follow the internal cabling regulations. Adapt it to the regulation in effect in each country.

Local setting switch SW3 (Set up at shipment OFF)

SW3-1	Defrost control change	The defrost operation interval becomes shorter by turning ON this switch. This switch should be turned ON in the area where outside temperature becomes below the freezing point.
SW3-2	Snow guard fan control	When this switch is turned ON, the outdoor fan will run for 30 seconds in every 10 minutes, when outdoor temperature falls to 3°C or lower and the compressor is not running when the unit is used in a very snowy country, set this switch to ON.
SW3-3,4	Trial operation	Method of trial operation ① Trial operation can be performed by using SW3-3,4. ② Compressor will be in the operation when SW3-3 is ON. ③ Cooling trial operation will be performed when SW3-4 is OFF, and heating trial operation when SW3-4 is ON. ④ Be sure to turn OFF SW3-3 after the trial operation is finished.

**Models FDC100VSX, 125VSX, 140VSX**

Item	Description
CH	Crankcase heater
CM	Compressor motor
CM-A-Z	Connector
CT	Current sensor
DH	Drain pan heater
DM	Diode module
F	Fuse
Fm1.2	Fan motor
IPM	Intelligent power module
L	Reactor
LED1	Indication lamp (GREEN)
LED2	Indication lamp (RED)
LPT	Low pressure sensor
SM1	Expansion valve for cooling
SM2	Expansion valve for heating
SW1	Pump down switch
SW3.5	Local setting switch
TB	Terminal block
Tho-A	Temperature sensor (Outdoor air)
Tho-D	Temperature sensor (Discharge pipe)
Tho-P	Temperature sensor (Heat exchanger pipe)
Tho-S	Temperature sensor (Suction pipe)
20S	Solenoid valve for 4-way valve
52C	Relay
52X1	Auxiliary relay (for CH)
52X2	Auxiliary relay (for DH)
52X3	Auxiliary relay (for 20S)
52X6	Auxiliary relay (for 52C)
63H1	High pressure switch

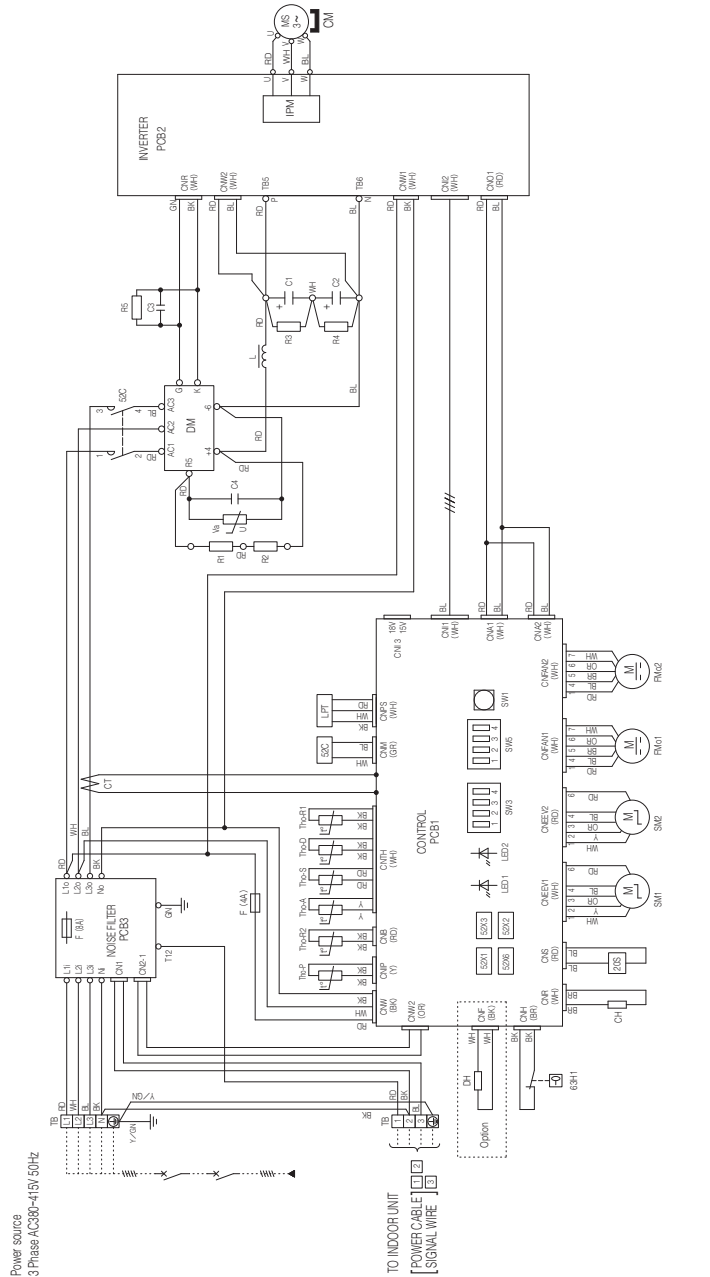

Power source  
3 Phase AC380-415/50Hz

Local setting switch SW3 (Set up at shipment OFF)

SW3-1	Defrost control change	The defrost operation interval becomes shorter by turning ON this switch. This switch should be turned ON in the area where outside temperature becomes below the freezing point.
SW3-2	Snow guard fan control	When this switch is turned ON, the outdoor unit fan will run for 30 seconds in every 10 minutes, when outdoor temperature falls to 3°C or lower and the compressor is not running when the unit is used in a very snowy country, set this switch to ON.
SW3-3,4	Trial operation	Method of trial operation ① Trial operation can be performed by using SW3-3,4. ② Compressor will be in the operation when SW3-3 is ON. ③ Cooling trial operation will be performed when SW3-4 is OFF, and heating trial operation when SW3-4 is ON. ④ Be sure to turn OFF SW3-3 after the trial operation is finished.

Power cable, indoor-outdoor connecting wires

Model	MAX over current (A)	Power cable size (mm <sup>2</sup> )	Power cable length (m)	Indoor-outdoor wire size x number	Earth wire size (mm)
FDC100	15	3.5	27	φ 1.6mm x 3	φ 1.6
FDC125					
FDC140					

- The specifications shown in the above table are for units without heaters. For units with heaters, refer to the installation instructions or the construction instructions of the indoor unit.
- Switchgear or circuit breaker capacity which is calculated from MAX. over current should be chosen along the regulations in each country.
- The cable specifications are based on the assumption that a metal or plastic conduit is used with no more than three cables contained in a conduit and a voltage drop is 2%. For an installation falling outside of these conditions, please follow the internal cabling regulations. Adapt it to the regulation in effect in each country.

Color marks

Mark	Color
BK	Black
BL	Blue
BR	Brown
OR	Orange
RD	Red
WH	White
Y	Yellow
Y/GN	Yellow/Green
GR	Gray
P	Pink

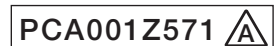

# 1.4 PIPING SYSTEM

(1) Single type  
Models FDT71, 100, 125, 140

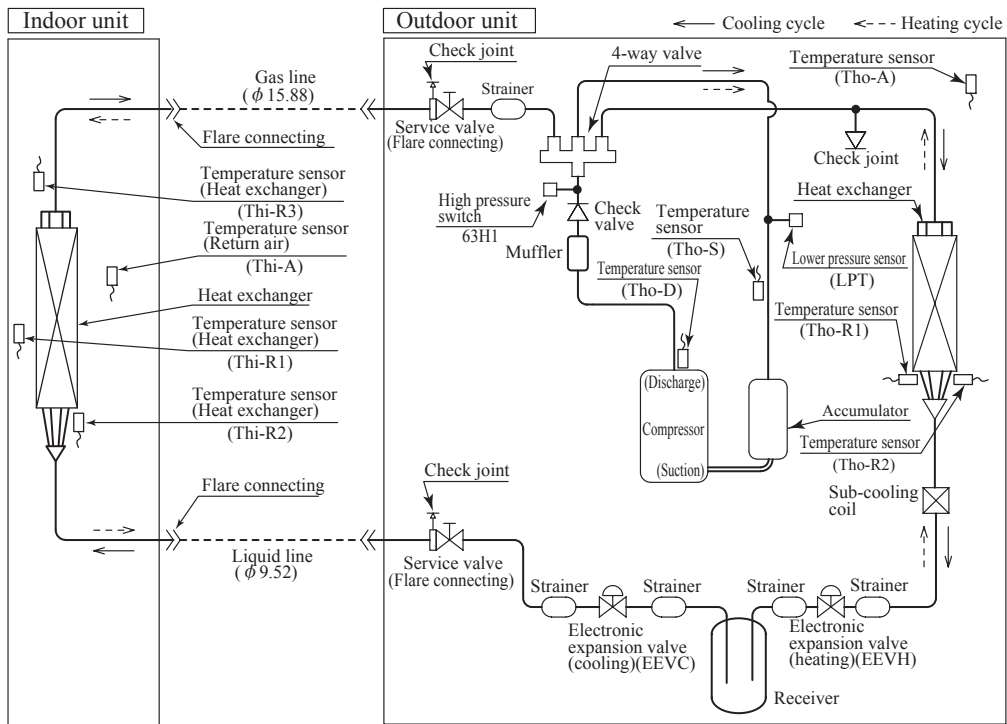

(2) Twin type  
Model FDT140

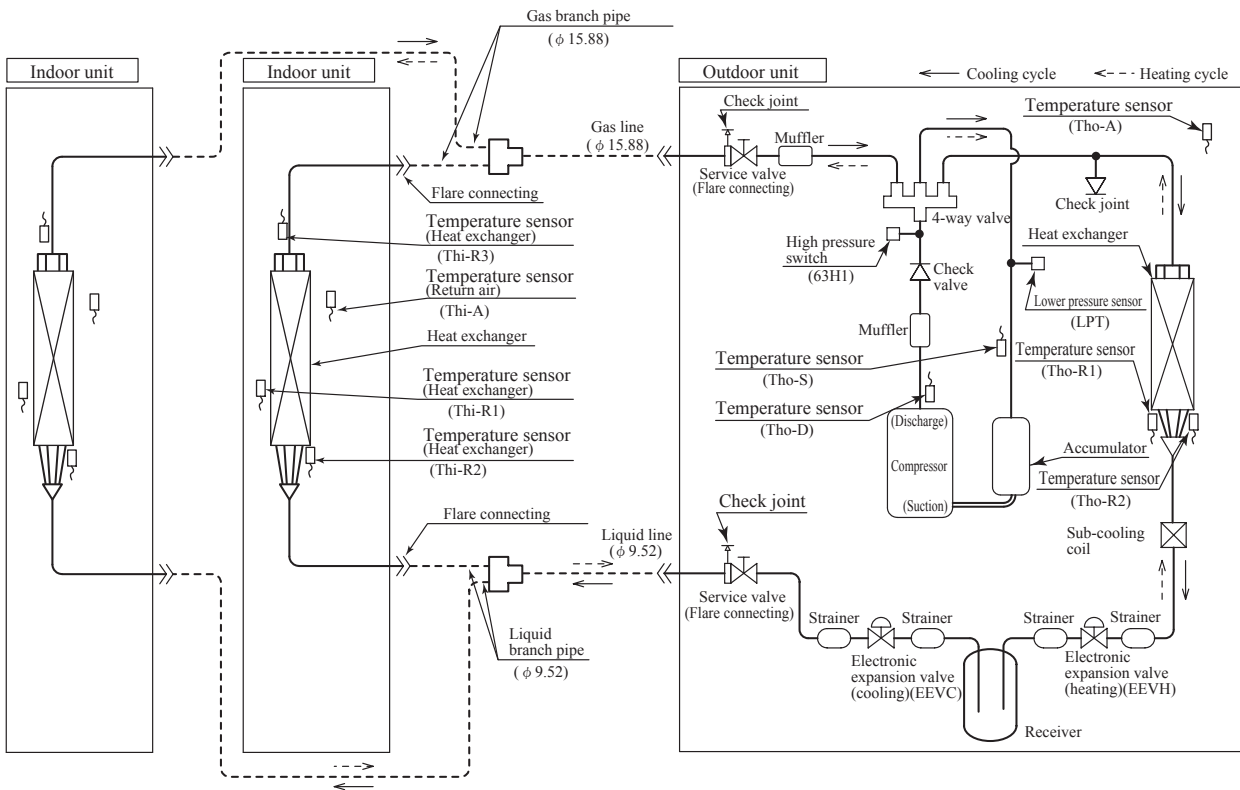

## Preset point of the protective devices

Parts name	Mark	Equipped unit	FDT71, 100, 125, 140 model
Temperature sensor (for protection overloading in heating)	Thi-R	Indoor unit	OFF 63°C ON 56°C
Temperature sensor (for frost prevention)	Thi-R		OFF 1.0°C ON 10°C
Temperature sensor (for protection high pressure in cooling)	Tho-R	Outdoor unit	OFF 65°C ON 51°C
Temperature sensor (for detecting discharge pipe temperature)	Tho-D	Outdoor unit	OFF 115°C ON 85°C
High pressure switch (for protection)	63H1	Outdoor unit	OFF 4.15MPa ON 3.15MPa
Low pressure sensor (for protection)	LPT	Outdoor unit	OFF 0.079MPa ON 0.227MPa

## 2. MICRO INVERTER PACKAGED AIR-CONDITIONERS

### CONTENTS

<b>2.1 OUTLINE OF OPERATION CONTROL BY MICROCOMPUTER</b>	<b>173</b>
<b>2.1.1 Remote control (Option parts)</b>	<b>173</b>
<b>2.1.2 Operation control function by the wired remote control</b>	<b>173</b>
<b>2.1.3 Operation control function by the indoor control</b>	<b>173</b>
<b>2.1.4 Operation control function by the outdoor control</b>	<b>173</b>
<b>( I ) Models FDC100—140VNA, 100—140VSA</b>	<b>173</b>
(1) Determination of compressor speed (Frequency)	173
(2) Compressor start control	174
(3) Compressor soft start control	174
(4) Outdoor fan control	175
(5) Defrost operation	176
(6) Protective control/anomalous stop control by compressor's number of revolutions	177
(7) Silent mode	180
(8) Test run	180
(9) Pump-down control	181
(10) Base heater ON/OFF output control (Option)	181
<b>(II) Models FDC200, 250VSA</b>	<b>183</b>
(1) Determination of compressor speed (Frequency)	183
(2) Compressor start control	183
(3) Compressor soft start control	184
(4) Outdoor fan control	184
(5) Defrost operation	186
(6) Protective control/anomalous stop control by compressor's number of revolutions	187
(7) Silent mode	191
(8) Test run	191
(9) Pump-down control	191
(10) Base heater ON/OFF output control (Option)	192
<b>2.2 MAINTENANCE DATA</b>	<b>192</b>
<b>2.3 ELECTRICAL WIRING</b>	<b>193</b>
<b>2.4 PIPING SYSTEM</b>	<b>197</b>

## 2.1 OUTLINE OF OPERATION CONTROL BY MICROCOMPUTER

- 2.1.1 Remote control (Option parts) ..... See page 4.
- 2.1.2 Operation control function by the wired remote control ..... See page 7.
- 2.1.3 Operation control function by the indoor control ..... See page 10.
- 2.1.4 Operation control function by the outdoor control

### (I) Models FDC100-140VNA, 100-140VSA

#### (1) Determination of compressor speed (Frequency)

##### Required frequency

- (a) Cooling/dehumidifying operation Unit: rps

Model		100	125	140	
Max. required frequency	Usual operation	90	105	105	
	Silent mode, outdoor temperature ≤ 15°C	SW7-3 OFF	60	80	85
		SW7-3 ON	47	50	53
Min. required frequency		15	15	15	

- (b) Heating operation Unit: rps

Model		100	125	140	
Max. required frequency	Usual operation	90	105	110	
	Silent mode	SW7-3 OFF	60	80	85
		SW7-3 ON	47	50	53
Min. required frequency		15	15	15	

- (c) If the indoor fan speed becomes “Me” or “Lo”, Max required frequency goes down accordingly depending on indoor unit model.
- (d) Max. required frequency under high outdoor air temperature in cooling mode  
Maximum required frequency is selected according to the outdoor air temperature (Tho-A).

Unit: rps

Model		100	125	140
Max. required frequency	Outdoor air temperature is 40°C or higher	75	90	96
	Outdoor air temperature is 46°C or higher	75	75	75

- (e) Max. required frequency under outdoor air temperature in heating mode  
Maximum required frequency is selected according to the outdoor air temperature (Tho-A).

Unit: rps

Model		100	125	140
Max. required frequency	Outdoor air temperature is 18°C or higher	60	80	85



- (f) Selection of max. required frequency by heat exchanger temperature
- 1) Maximum required frequency is selected according to the outdoor unit heat exchanger temperature (Tho-R) during cooling/dehumidifying or according to the indoor unit heat exchanger temperature (Thi-R) during heating mode.
  - 2) When there are 3 indoor unit heat exchanger temperatures (Thi-R), whichever the highest applies.

Unit: rps

Model		100	125	140	
Max. required frequency	Cooling/dehumidifying	Outdoor unit heat exchanger temperature is 56°C or higher	90	100	100
	Heating	Indoor unit heat exchanger temperature is 56°C or higher	90	100	100

- (g) When any of the controls from (a) to (f) above may duplicate, whichever the smallest value among duplicated controls is taken as the maximum required frequency.
- (h) During heating, it is operated with the maximum required frequency until the indoor unit heat exchanger temperature becomes 40°C or higher.

**(2) Compressor start control**

- (a) Compressor starts upon receipt of the thermostat ON signal from the indoor unit.
- (b) However, at initial start after turning the power source breaker, it may enter the standby state for maximum 30 minutes (“ PREPARATION” is displayed on the remote control) in order to prevent the oil loss in the compressor.  
If the cooling/dehumidifying/heating operation is selected from the remote control when the outdoor unit is in the standby state, “ PREPARATION” is displayed for 3 seconds on the remote control.

**(3) Compressor soft start control**

**(a) Compressor protection start I**

[Control condition]

Normally, the compressor operation frequency is raised in this start pattern.

[Control contents]

- a) Starts with the compressor’s target frequency at **A** rps.  
However, when the ambient air temperature (Tho-A) is 35°C or higher during cooling/dehumidifying or the indoor return air temperature (Thi-A) is 25°C or higher during heating, it starts at **C** rps.
- b) At 30 seconds after the start of compressor, its target frequency changes to **B** rps and the compressor is operated for 2 - 4 minutes with its operation frequency fixed at **B** rps.

Model	Operation mode	A rps	B rps	C rps
100-140	Cooling/Dehumidifying	55	55	30
	Heating	55	55	30

**(b) Compressor protection start III**

[Control condition]

Number of compressor starts is only 1 counted after the power source breaker ON.

[Control contents]

Operates by selecting one of following start patterns according to the operation mode and the outdoor air temperature (Tho-A).

- (i) Low frequency operation control during cooling/dehumidifying

[Control condition]

Upon establishing the conditions of compressor protection start III, the low frequency operation control is performed during cooling/dehumidifying.

[Control contents]

- ① Starts with the compressor’s target frequency at **A** rps. When the outdoor air temperature (Tho-A) is 35°C or higher, it starts at **C** rps.
- ② At 30 seconds after the compressor start, the compressor’s target frequency is changed to **B** rps and the compressor’s operation frequency is fixed for 10 minutes.

Model	Operation mode	A rps	B rps	C rps
100-140	Cooling/Dehumidifying	55	55	30

- (ii) Low frequency operation control during heating

[Control condition]

When the conditions of compressor protection start III are established and the following condition is satisfied, the low number of revolutions operation control is performed during heating.

- ① At 30 minutes or more after turning the power source breaker on

[Control contents]

- ① Starts the compressor with its target frequency at **A** rps. However, when the indoor unit return air temperature (Thi-A) is 25°C or higher, it start at **C** rps.
- ② At 30 seconds after the start of compressor, the compressor’s target frequency is changed to **B** rps and the compressor’s operation frequency is fixed for 10 minutes.

Model	Operation mode	A rps	B rps	C rps
100-140	Heating	55	55	30



**(4) Outdoor fan control**

**(a) Outdoor fan tap and fan motor speed**

Unit: min<sup>-1</sup>

Model	Mode	Fan motor tap						
		① speed	② speed	③ speed	④ speed	⑤ speed	⑥ speed	⑦ speed
100-140	Cooling/Dehumidifying	200	350	600 <sup>(1)</sup>	740	820	870	950
	Heating	200	350	600 <sup>(1)</sup>	740	820	870	950

Note (1) If the “silent mode start” signal is received from the remote control, the speed changes from 600 to 500.

**(b) Fan tap control during Cooling/Defumidifying operation**

Fan taps are selected depending on the outdoor unit heat exchanger temperature (Tho-R1, R2) and the outdoor air temperature (Tho-A).

Note (1) It is detected by Tho-R1 or R2, whichever the higher.

	Ⓐ zone	Ⓑ zone	Ⓒ zone	Ⓓ zone
Ⓐ zone	Tap 5	Tap 5	Tap 5	Tap 4
Ⓑ zone	Tap 5	Tap 5	Tap 4 <sup>(1)</sup>	Tap 3
Ⓒ zone	Tap 4	Tap 4 <sup>(1)</sup>	Tap 3	Tap 2
Ⓓ zone	Tap 3	Tap 3	Tap 2	Tap 1

Note (1) If the “silent mode start” signal is received from the remote control, the speed changes from Tap 4 to Tap 3.

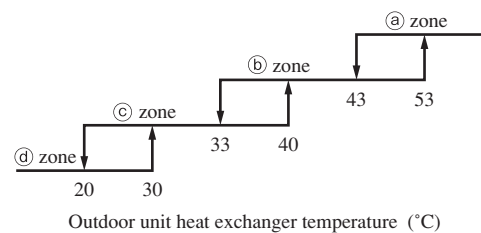
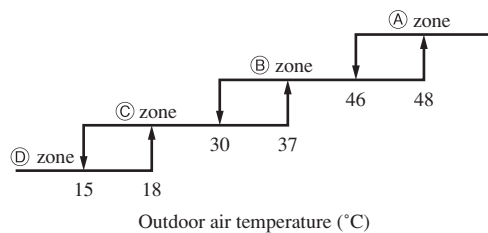

**(c) Fan tap control during heating operation**

Fan taps are selected depending on the outdoor unit heat exchanger temperature (Tho-R1, R2) and the outdoor air temperature (Tho-A).

Note (1) It is detected by Tho-R1 or R2, whichever the lower.

	Ⓐ zone	Ⓑ zone	Ⓒ zone
Ⓐ zone	Tap 3	Tap 3	Tap 4
Ⓑ zone	Tap 3	Tap 4 <sup>(1)</sup>	Tap 5
Ⓒ zone	Tap 4	Tap 5	Tap 6

Note (1) If the “silent mode start” signal is received from the remote control, the speed changes from Tap 4 to Tap 3.

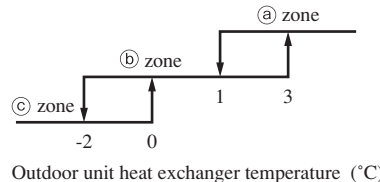
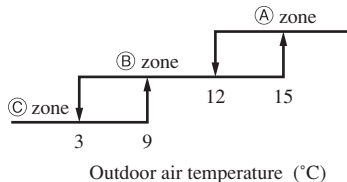

**(d) Outdoor fan control at cooling low outdoor air**

i) When all the following conditions are established after the start of compressor, the following control is implemented.

If the outdoor air temperature (Tho-A) is in the zone Ⓑ in the cooling/dehumidifying mode, it has elapsed 20 seconds from the start of outdoor fan and the outdoor fan is at the tap 1 speed, the outdoor fan speed is controlled according to the outdoor unit heat exchanger temperature (Tho-R1, R2).

Note (1) It is detected with Tho-R1 or R2, whichever the higher.

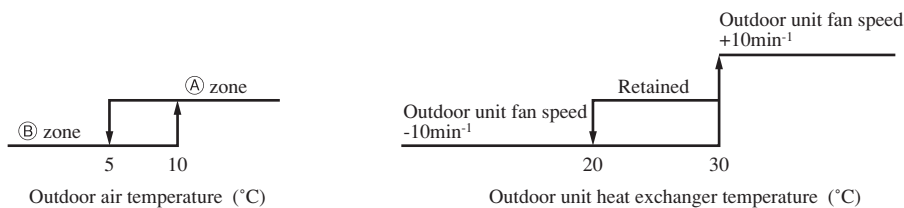

- ii) The outdoor unit heat exchanger temperature is detected always and, when the number of revolutions of the outdoor fan speed has been increased or decreased, there is no change of fan speed for 20 seconds.
- iii) Range of the outdoor fan speed under this control is as follows.
  - a) Lower limit:  $130\text{min}^{-1}$
  - b) Upper limit:  $500\text{min}^{-1}$
- iv) As any of the following conditions is established, this control terminates.
  - a) When the outdoor air temperature is in the zone ① and the outdoor unit heat exchanger temperature at  $30^{\circ}\text{C}$  or higher is established for 40 seconds or more continuously.
  - b) When the outdoor fan speed is  $500\text{min}^{-1}$  and the outdoor unit heat exchanger temperature at  $30^{\circ}\text{C}$  or higher is established for 40 seconds or more continuously.
  - c) When the outdoor unit heat exchanger temperature at  $45^{\circ}\text{C}$  or higher is established for 40 seconds or more.

**(e) Caution at the outdoor fan start control (3 phase models only)**

When the outdoor fan is running at  $400\text{min}^{-1}$  before operating the compressor, it may operate with the compressor only, without starting up the outdoor fan. This is normal.

**(f) Snow protection fan control**

If the DIP switch (SW3-2) on the outdoor unit control PCB is turned ON, the outdoor fan is operated for 30 seconds at 4 tap speed once in every 10 minutes depending on the outdoor air temperature (detected with Tho-A) in the stop mode or anomalous stop mode.

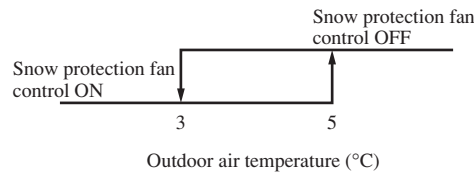

**(5) Defrost operation**

**(a) Starting conditions**

If all of the following defrost operation conditions A or conditions B are satisfied, the defrost operation starts.

- i) Defrost conditions A
  - a) Cumulative compressor operation time after the end of defrost operation has elapsed 37 minutes, and the cumulative compressor operation time after the start of heating operation (remote control ON) has elapsed 30 minutes.
  - b) After 5 minutes from the compressor ON
  - c) After 5 minutes from the start of outdoor fan
  - d) After satisfying all above conditions, if temperatures of the outdoor unit heat exchanger temperature sensor (Tho-R1, R2) and the outdoor air temperature sensor (Tho-A) become lower than the defrost operation start temperature as shown by the right figure for 15 seconds continuously.
- ii) Defrost conditions B
  - a) When previous defrost ending condition is the time out of defrost operation and it is in the heating operation after the cumulative compressor operation time after the end of defrost operation has become 30 minutes.
  - b) After 5 minutes from the start of compressor
  - c) After 5 minutes from the start of outdoor fan

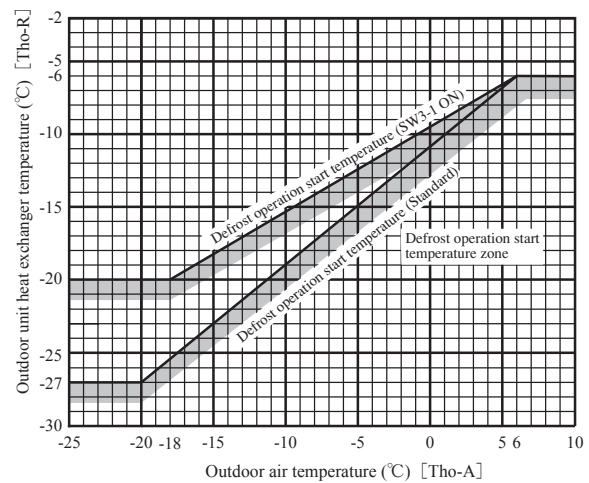

**(b) Ending conditions**

When any of the following conditions is satisfied, the heating operation starts.

- i) When it has elapsed 8 minutes and 20 seconds after the start of defrost operation.
- ii) When the outdoor unit heat exchanger temperatures (Tho-R1, R2), whichever the lower, becomes  $7^{\circ}\text{C}$  or higher for 10 seconds continuously.

**(c) Switching of defrost operation with SW3-1**

- i) If SW3-1 on the outdoor unit control PCB is turned to ON, it becomes easier to enter the defrost operation. Use this when installing a unit at snowing regions.
- ii) Control contents
  - a) It allows entering the defrost operation under the defrost condition A when the cumulative heating operation time becomes 30 minutes. It is 37 minutes at SW3-1 OFF (Factory default).
  - b) It allows entering the defrost operation under the defrost condition B when the cumulative heating operation time becomes 25 minutes. It is 30 minutes at SW3-1 OFF (Factory default).
  - c) It allows the defrost operation with the outdoor unit heat exchanger temperature (Tho-R).

**(6) Protective control/anomalous stop control by compressor's number of revolutions**

**(a) Compressor discharge pipe temperature protection**

- i) Protective control  
As the discharge pipe temperature (detected with Tho-D) exceeds the setting value, the compressor speed (frequency) is controlled to suppress the rise of discharge pipe temperature.

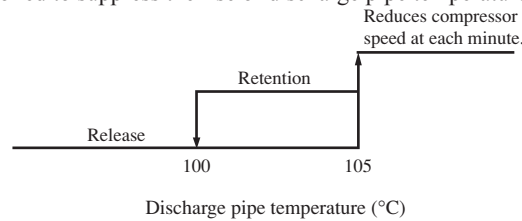

- ii) Anomalous stop control
  - a) If the discharge pipe temperature (detected with Tho-D) exceeds the setting value, the compressor stops.
  - b) When it is detected 2 times within 60 minutes or after continuous 60 minutes, including the stop of compressor, E36 is displayed on the remote control and it enters the anomalous stop mode.

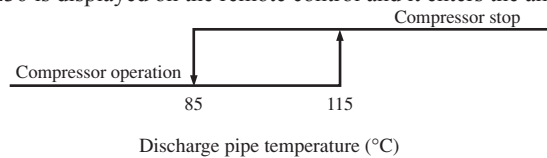

- iii) Reset of anomalous stop mode  
As it drops to the reset value of 85°C or lower for 45 minutes continuously, it becomes possible to restart from the remote control.

**(b) Cooling high pressure protection**

- i) Protective control
  - a) When the outdoor air temperature (Tho-A) is 40°C or higher and the outdoor unit heat exchanger temperature (Tho-R) exceeds the setting value, the compressor speed (frequency) is controlled to suppress the rise of high pressure.
  - b) Control value A is updated to an optimum value automatically according to the operating conditions.

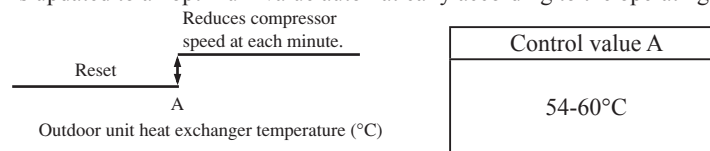

- ii) Anomalous stop control
  - a) As the outdoor unit heat exchanger temperature (Tho-R) exceeds the setting value, the compressor stops.
  - b) If it is detected 5 times within 60 minutes or 65°C or higher continues for 60 minutes, including the stop of compressor, E35 is displayed on the remote control and it enters the anomalous stop mode.

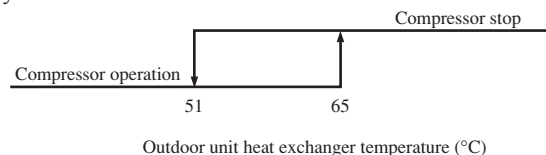

- iii) Reset of anomalous stop mode  
As it reaches the reset value of 51°C or lower, it becomes possible to restart from the remote control.

**(c) Heating high pressure protection**

(i) Protective control

- a) As the indoor unit heat exchanger temperature (Thi-R) exceeds the setting value, the compressor speed (frequency) is controlled to suppress the rise of high pressure.
- b) Control value A is updated to an optimum value automatically according to the operating conditions.

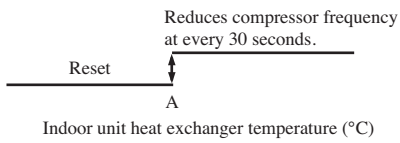

Model	Existing piping adaptation switch: SW5-1	
	OFF (Shipping)	ON
	Control value A (°C)	
100-140	48-54	46-52

Note (1) Adaptation to existing piping is at ON.

(ii) Anomalous stop control

Operation control function by the indoor unit control - See the heating overload protection, page 18.

(iii) Adaptation to existing piping, stop control

If the existing piping adaptation switch, SW5-1, is turned ON, the compressor stops to protect existing piping when the indoor unit heat exchanger temperature (Thi-R) exceeds the setting value.

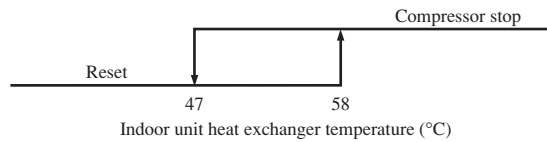

**(d) Anomaly detection control by the high pressure switch (63H1)**

- (i) If the pressure rises and operates the high pressure switch (opens at 4.15MPa/closes at 3.15MPa), the compressor stops.
- (ii) Under any of the following conditions, E40 is displayed and it enters the anomalous stop mode.
  - a) When it occurs 5 times within 60 minutes that pressure rises and the compressor is stopped by 63H1.
  - b) When 63H1 has been in the open state for 60 minutes continuously, including the stop of compressor.

**(e) Compressor pressure ratio protection control**

- (i) During heating operation, if the indoor unit heat exchanger temperature (Thi-R) and the low pressure saturation temperature (SST) exceed the setting values at 10 minutes after the start of compressor, the compressor speed (frequency) is controlled to protect the compressor.
- (ii) This control is not performed during the outdoor fan ON and for 10 minutes from the start of outdoor fan.
- (iii) This control is not performed during defrost operation and at 10 minutes after the reset of defrost operation.
- (iv) When there are 3 indoor unit heat exchanger temperatures (Thi-R), the highest temperature is detected.

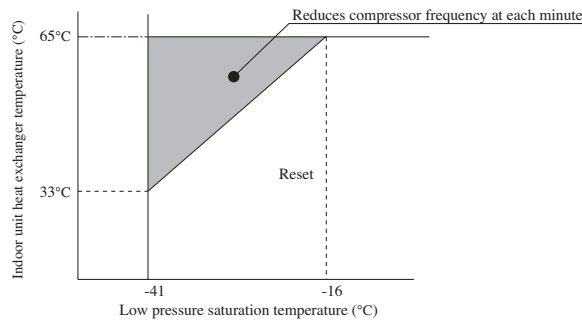

**(f) Over-current protection current safe controls I, II**

Detecting the outdoor unit inverter input (primary) current and the output (secondary) current, if the current values exceed setting values, the compressor speed (frequency) is controlled to protect the inverter.

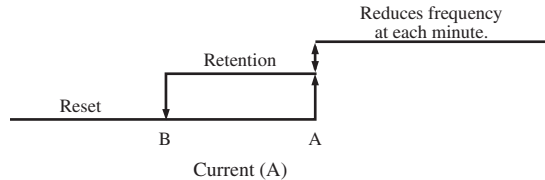

Model	Cooling		Heating		
	Control value A	Reset value B	Control value A	Reset value B	
Primary current side	100	13.5 (23.0)	12.5 (22.0)	13.5 (23.0)	12.5 (22.0)
	125, 140	13.5 (23.0)	12.5 (22.0)	13.5 (23.0)	12.5 (22.0)
Secondary current side	100	12.0 (Fig.C)	11.0 (A-1)	12.0 (23)	11.0 (22)
	125, 140	12.0 (Fig.C)	11.0 (A-1)	12.0 (23)	11.0 (22)

Note (1) Value in ( ) are for the single phase models.

(Fig. C) The control value "A" and the reset value vary depending on the compressor speed.

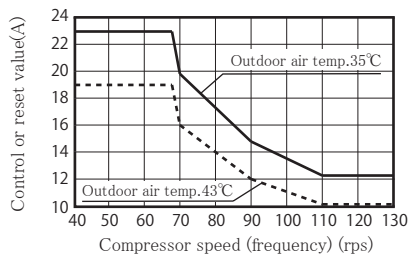

**(g) Power transistor temperature protection**

Anomalous stop control

- (i) If the power transistor drops supply voltage, the protective switch in the power transistor operates to protect the compressor and the power transistor.
- (ii) Under any of the following condition, E41 is displayed and it enters the anomalous stop mode.
  - i) When the protective switch in the power transistor operates 5 times within 60 minutes and the compressor stops.

**(h) Anomalous power transistor current**

- (i) Prevents over-current on the inverter. If the current value in the power transistor exceeds the setting value, the compressor stops.
- (ii) If the current value in the power transistor exceeds the specified value and the compressor stops 4 times within 30 minutes, E42 is displayed on the remote control and it enters the anomalous stop mode.

**(i) Anomalous inverter PCB**

If the power transistor detects any anomaly for 15 minutes, including the stop of compressor, E51 is displayed on the remote control and it enters the anomalous stop mode.

**(j) Anti-frost control by the compressor frequency control**

- (i) If the indoor unit heat exchanger temperature (detected with Thi-R) exceeds the setting value at 4 minutes after the start of compressor, the compressor speed (frequency) is controlled to initiate the anti-frost control of indoor unit heat exchanger.
- (ii) When there are 3 indoor unit heat exchanger temperatures (Thi-R), the lowest temperature is detected.

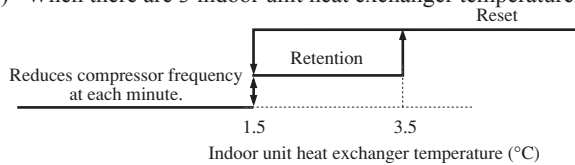

- (iii) Regarding the anti-frost control by the operation stop, refer to the operation control function by the indoor unit control and the cooling, dehumidifying frost prevention of page 18.

**(k) Dewing prevention control**

[Control condition] During cooling and dehumidifying operation, if all the following conditions are established, the compressor speed (frequency) is reduced to prevent dewing and water splash.

- ① Cooling electronic expansion valve aperture (EEVC) is 500 pulses.
- ② Suction overheat is 10°C or higher.
- ③ Compressor speed (frequency) is 60 rps or higher.

[Control contents] ① When the suction overheat is 10°C or higher, the compressor speed (frequency) is reduced at each 1 minute.

- ② Compressor speed (frequency) does not rise till the cooling expansion valve becomes 460 pulses.
- ③ This control takes 60 rps as its lower limit so that compressor speed is not controlled when it is less than 60 rps.

**(l) Refrigerant quantity shortage protection**

Under the compressor protection start III control during cooling and dehumidifying operations, the following control is performed by detecting the indoor unit heat exchanger temperature (Thi-R) and the indoor unit return air temperature (Thi-A).

[Control condition] When the state that the indoor unit heat exchanger temperature (Thi-R) does not become lower than the indoor unit return air temperature (Thi-A) by 4°C or more continues for 1 minute.

[Control contents] It judges that the flowing of refrigerant in to the indoor unit is insufficient so that the compressor is stopped and E57 is displayed on the remote control.

**(m) Broken wire detection on temperature sensor**

- i) Outdoor unit heat exchanger temperature sensor and outdoor air temperature sensor

If the following is detected for 5 second continuously within 2 minutes to 2 minutes and 20 seconds after the compressor ON, the compressor stops. After a delay of 3 minutes, it restarts but, if the same is detected repeatedly 3 times within 40 minutes, the compressor stops with the anomalous stop.

Note (1) During defrost operation and for 3 minutes after the end of defrost operation, it is not detected.

- Outdoor unit heat exchanger temperature sensor: -50°C or lower
- Outdoor air temperature sensor: -45°C or lower

- ii) Discharge pipe temperature sensor and suction pipe temperature sensor

If the following is detected for 5 second continuously within 10 minutes to 10 minutes and 20 seconds after the compressor ON, the compressor stops. After a delay of 3 minutes, it restarts but, if the same is detected repeatedly 3 times within 40 minutes, the compressor stops with the anomalous stop.

Note (1) During defrost operation and for 3 minutes after the end of defrost operation, it is not detected.

- Discharge pipe temperature sensor: -10°C or lower
- Suction pipe temperature sensor: -50°C or lower

**(n) Fan motor error**

- i) If the fan speed of 100min<sup>-1</sup> or under is detected for 30 seconds continuously under the outdoor fan control (with the operation command of fan tap at ① speed or higher), the compressor stops.
- ii) When the fan motor speed drops to 100min<sup>-1</sup> or under 5 times within 60 minutes and the compressor stops, it enters the anomalous stop mode with E48 displayed on the remote control.

**(o) Anomalous stop by the compressor start stop**

- i) When it fails to shift to the compressor DC motor's rotor position deflection operation at 5 seconds after establishing the compressor start condition, the compressor stops temporarily and restarts 3 minutes later.
- ii) If it fails to shift to the position detection operation again at second time, it judges the anomalous compressor start and stops the compressor by the anomalous stop (E59).

**(7) Silent mode**

- (a) As "Silent mode start" signal is received from the remote control, it operates by dropping the outdoor fan tap and the compressor speed (frequency).
- (b) For details, refer to items (1) and (4) above.

**(8) Test run**

- (a) It is possible to operate from the outdoor unit using the DIP switch on the outdoor unit control PCB.

SW3-3	ON	SW3-4	OFF	Cooling test run
			ON	Heating test run
	OFF	Normal and end of test run		

Make sure to turn SW3-3 to OFF after the end of operation.

**(b) Test run control**

- i) Operation is performed at the maximum compressor speed (frequency), which is determined for each model.
- ii) Each protective control and error detection control are effective.
- iii) If SW3-4 is switched during test run, the compressor is stopped for once by the stop control and the cooling/heating operation is switched.
- iv) Setting and display of remote control during test run

Mode \ Item	Contents of remote control setting/display
Cooling test run	Setting temperature of cooling is 5°C.
Heating test run	Setting temperature of heating (preparation) is 30°C.

**(9) Pump-down control**

When SW7-1 is OFF, turning ON the pump-down switch SW1 for 2 seconds during the operation stop or anomalous stop (excluding the thermostat OFF), the pump-down operation is performed. (This is invalid when the indoor unit is operating. This is effective even when the indoor unit is stopped by the anomalous stop or the power source is turned OFF.)

**(a) Control contents**

- (i) Close the service valve at the liquid side. (It is left open at the gas side.)
- (ii) Compressor is started with the target speed (frequency) at 55 rps in the cooling mode.
- (iii) Red and green lamps (LED) flash continuously on the outdoor unit control PCB.
- (iv) Each of protection and error detection controls, excluding the low pressure control, anti-frost control and dewing prevention control, is effective.
- (v) Outdoor unit fan is controlled as usual.
- (vi) Electronic expansion valve is fully opened.

**(b) Ending conditions**

Stop control is initiated depending on any of the following conditions.

- (i) Suction pipe temperature of  $-36^{\circ}\text{C}$  or lower is detected for 5 seconds continuously.
  - a) Red LED: Light, Green LED: Flashing, Remote control: Displays stop.
  - b) It is possible to restart when the suction pipe temperature of  $-36^{\circ}\text{C}$  or higher.
  - c) Electronic expansion valve (cooling/heating) is kept fully open.
- (ii) Stop by the error detection control
  - a) Red LED: Flashing, Green LED: Flashing
  - b) Restart is prohibited. To return to normal operation, reset the power source.
  - c) Electronic expansion valve (cooling/heating) is left fully open.
- (iii) When the cumulative operation time of compressor under the pump-down control becomes 5 minutes.
  - a) Red LED: OFF, Green LED: Flashing, Remote control: Stop
  - b) It is possible to pump-down again.
  - c) Electronic expansion valve (cooling/heating) is left fully open.

Note (1) After the stop of compressor, close the service valve at the gas side.

Caution: Since pressing the pump-down switch cancels communications with the indoor unit, the indoor unit and the remote control display "Transmission error – E5". This is normal.

**(10) Base heater ON/OFF output control (Option)****(a) Base heater ON conditions**

When all of following conditions are satisfied, the base heater is turned ON.

- When power source is turned ON
- During the compressor stop and when "heater OFF condition" indicated in the following (c) isn't formed
- For 5 minutes from the compressor start
  - But, when the compressor ON condition is formed and when it's heater OFF by the following (c) item, the heater isn't tured ON.
- During defrost operation

**(b) Base heater OFF conditions**

When all of following conditions are satisfied, the base heater is turned OFF.

- When it has passed for 5 minutes or more from the compressor start
- After it passed for 5 minutes from defrost operation return
- When "heater OFF condition" indicated in the following (c) is formed

**(c) Base heater ON/OFF condition**

After the compressor stop, the base heater ON/OFF changes the control method by the outdoor air temperature [Tho-A].

- (i) When the outdoor air temperature is A territory  
After the compressor stop, the base heater is always turned ON.
- (ii) When the outdoor air temperature is B territory  
(ii-1) After it passed for 8 minutes 30 seconds from the compressor stop, the base heater is turned OFF.  
(ii-2) (ii-1) later, after it passed for 8 hours from the compressor stop, the base heater is always turned ON.
- (iii) When the outdoor air temperature is C territory  
After the compressor stop, the base heater is always turned OFF.

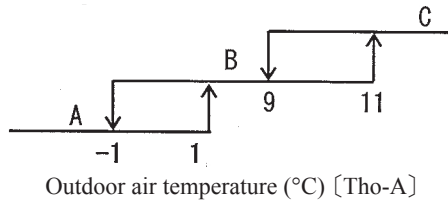



**(II) Models FDC200, 250VSA**

**(1) Determination of compressor speed (Frequency)**

**Required frequency**

- (a) Cooling/dehumidifying operation. Unit: rps

Model		FDC200	FDC250
Max. required frequency	Usual operation	120	120
	Outdoor air temperature $\leq 15^{\circ}\text{C}$ or indoor return air temperature $\leq 20^{\circ}\text{C}$	100	100
	Silent mode	80 (100)	70 (100)
Min. required frequency		15	20

Note(1) Value in ( ) are for the SW7-3 OFF.

- (b) Heating operation. Unit: rps

Model		FDC200	FDC250
Max. required frequency	Usual operation	120	120
	Silent mode	80 (100)	70 (100)
Min. required frequency		15	20

Note(1) Value in ( ) are for the SW7-3 OFF.

- (c) If the indoor fan speed becomes “Me” or “Lo”, Max required frequency goes down accordingly depending on indoor unit model.  
 (d) Max. required frequency under high outdoor air temperature in cooling mode.  
 Maximum required frequency is selected according to the outdoor air temperature (Tho-A).

Unit: rps

Model		FDC200	FDC250
Max. required frequency	Outdoor air temperature is $40^{\circ}\text{C}$ or higher	100	120

- (e) Max. required frequency under outdoor air temperature in heating mode.  
 Maximum required frequency is selected according to the outdoor air temperature (Tho-A).

Unit: rps

Model		FDC200	FDC250
Max. required frequency	Outdoor air temperature is $10^{\circ}\text{C}$ or higher	120	120
	Outdoor air temperature is $18^{\circ}\text{C}$ or higher	100	120



- (f) Selection of max. required frequency by heat exchanger temperature.  
 (i) Maximum required frequency is selected according to the outdoor heat exchanger temperature (Tho-R) during cooling/dehumidifying or according to the indoor heat exchanger temperature (Thi-R) during heating mode.  
 (ii) When there are 3 indoor heat exchanger temperatures (Thi-R), whichever the highest applies,

Unit: rps

Model			FDC200	FDC250
Max. required frequency	Cooling/dehumidifying	Outdoor heat exchanger temperature is $56^{\circ}\text{C}$ or higher	110	120
	Heating	Indoor heat exchanger temperature is $56^{\circ}\text{C}$ or higher	120	120

- (g) When any of the controls from (a) to (f) above may duplicate, whichever the smallest value among duplicated controls is taken as the maximum required frequency.  
 (h) During heating, it is operated with the maximum required frequency until the indoor heat exchanger temperature becomes  $40^{\circ}\text{C}$  or higher.

**(2) Compressor start control**

- (a) Compressor starts upon receipt of the thermostat ON signal from the indoor unit.  
 (b) However, at initial start after turning the power source breaker, it may enter the standby state for maximum 30 minutes (“ PREPARATION” is displayed on the remote control) in order to prevent the oil loss in the compressor.  
 If the cooling/dehumidifying/heating operation is selected from the remote control when the outdoor unit is in the standby state, “ PREPARATION” is displayed for 3 seconds on the remote control.

**(3) Compressor soft start control****(a) Compressor protection start I**

[Control condition]

Normally, the compressor operation frequency is raised in this start pattern.

[Control contents]

- (i) Starts with the compressor's target frequency at
- A**
- rps.

However, when the outdoor air temperature (Tho-A) is 35°C or higher during cooling/dehumidifying or the indoor return air temperature (Thi-A) is 25°C or higher during heating, it starts at **C** rps.

- (ii) At 30 seconds after the start of compressor, its target frequency changes to
- B**
- rps and the compressor is operated for 2 - 4 minutes with its operation frequency fixed at
- B**
- rps.

Model	Operation mode	<b>A</b> rps	<b>B</b> rps	<b>C</b> rps
FDC200	Cooling/Dehumidifying	45	45	25
	Heating	45	45	25
FDC250	Cooling/Dehumidifying	55	55	30
	Heating	55	55	30

**(b) Compressor protection start III**

[Control condition]

Number of compressor starts is only 1 counted after the power source breaker ON.

[Control contents]

Operates by selecting one of following start patterns according to the operation mode and the outdoor air temperature (Tho-A).

- (i) Low frequency operation control during cooling/dehumidifying.

[Control condition]

Upon establishing the conditions of compressor protection start III, the low frequency operation control is performed during cooling/dehumidifying.

[Control contents]

- Starts with the compressor's target frequency at **A** rps. When the outdoor air temperature (Tho-A) is 35°C or higher, it starts at **C** rps.
- At 30 seconds after the compressor start, the compressor's target frequency is changed to **B** rps and the compressor's operation frequency is fixed for 10 minutes.

Model	Operation mode	<b>A</b> rps	<b>B</b> rps	<b>C</b> rps
FDC200	Cooling/Dehumidifying	45	45	25
FDC250	Cooling/Dehumidifying	55	55	30

- (ii) Low frequency operation control during heating.

[Control condition]

When the conditions of compressor protection start III are established and one of following conditions. a) is satisfied, the low frequency operation control is performed during heating.

- a) At 30 minutes or more after turning the power source breaker on.

[Control contents]

- If the compressor starts with 6 hours after the power source breaker turns on, and outdoor air temperature is lower than -2°C, unit starts by cooling mode for 3 minutes to prevent the liquid refrigerant from returning to compressor. (model FDC200 only)
- Starts the compressor with its target frequency at **A** rps. However, when the indoor return air temperature (Thi-A) is 25°C or higher, it starts at **C** rps.
- At 30 seconds after the start of compressor, the compressor's target frequency is changed to **B** rps and the compressor's operation frequency is fixed for 6-10 minutes.

Model	Operation mode	<b>A</b> rps	<b>B</b> rps	<b>C</b> rps
FDC200	Heating	45	30	25
FDC250	Heating	55	30	30

**(4) Outdoor fan control****(a) Outdoor fan tap and fan motor speed**Unit: min<sup>-1</sup>

Model	Mode	Fan motor tap						
		① speed	② speed	③ speed	④ speed	⑤ speed	⑥ speed	⑦ speed
FDC200	Cooling/Dehumidifying	200	390	560	830	870	910	950
	Heating	200	390	560	830	870	910	950
FDC250	Cooling/Dehumidifying	200	370	600	750	850	900	950
	Heating	200	370	600	820	850	910	950

**(b) Fan tap control during Cooling/Defumidifying operation**

Fan taps are selected depending on the outdoor heat exchanger temperature (Tho-R1, R2) and the outdoor air temperature (Tho-A).  
 Note (1) It is detected by Tho-R1 or R2, whichever the higher.

	(A) zone	(B) zone	(C) zone	(D) zone
(a) zone	Tap 5(6)	Tap 5(6)	Tap 6(5/6)	Tap 4
(b) zone	Tap 5	Tap 5	Tap 4	Tap 3
(c) zone	Tap 4	Tap 4	Tap 3	Tap 2
(d) zone	Tap 3	Tap 3	Tap 2	Tap 1

Note (1) Value in ( ) are for the model FDC200.

• Silent mode only

	(A) zone	(B) zone	(C) zone	(D) zone
(a) zone	Tap 5	Tap 5	Tap 4(5)	Tap 4
(b) zone	Tap 4	Tap 4	Tap 3	Tap 3
(c) zone	Tap 4	Tap 3	Tap 3	Tap 2
(d) zone	Tap 3	Tap 3	Tap 2	Tap 1

Note (1) Value in ( ) is for the model FDC200.

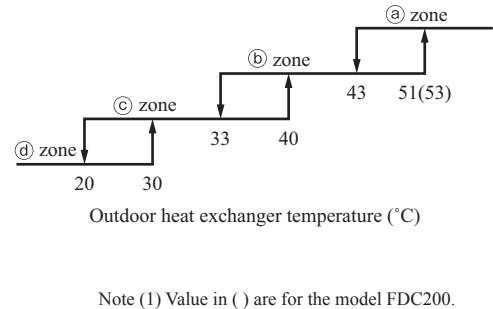
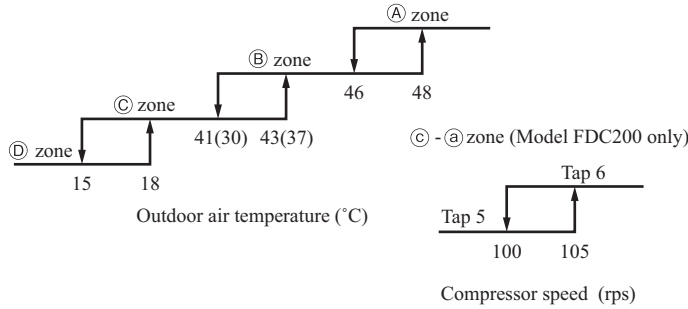

**(c) Fan tap control during heating operation**

Fan taps are selected depending on the outdoor heat exchanger temperature (Tho-R1, R2) and the outdoor air temperature (Tho-A).  
 Note (1) It is detected by Tho-R1 or R2, whichever the lower.

	(A) zone	(B) zone	(C) zone
(a) zone	Tap 3	Tap 3	Tap 4
(b) zone	Tap 3	Tap 4	Tap 5
(c) zone	Tap 4	Tap 7(5)	Tap 7(6)

Note (1) Value in ( ) are for the model FDC200.

• Silent mode only

	(A) zone	(B) zone	(C) zone
(a) zone	Tap 3	Tap 3	Tap 3
(b) zone	Tap 3	Tap 3	Tap 4
(c) zone	Tap 3(4)	Tap 5(4)	Tap 6(5)

Note (1) Value in ( ) are for the model FDC200.

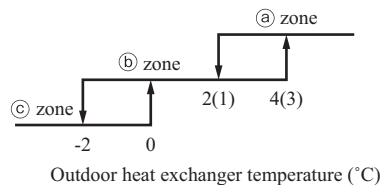
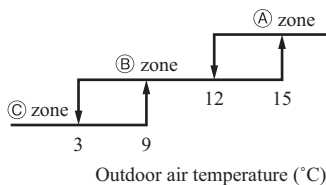

**(d) Outdoor fan control at cooling low outdoor air**

- (i) When all the following conditions are established after the start of compressor, the following control is implemented. If the outdoor air temperature (Tho-A) is in the zone (B) in the cooling/dehumidifying mode, it has elapsed 20 seconds from the start of outdoor fan and the outdoor fan is at the tap 1 speed, the outdoor fan speed is controlled according to the outdoor heat exchanger temperature (Tho-R1, R2).  
 Note (1) It is detected with Tho-R1 or R2, whichever the higher.

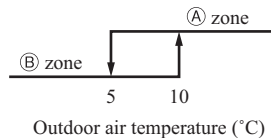

- (ii) The outdoor heat exchanger temperature is detected always and, when the number of revolutions of the outdoor fan speed has been increased or decreased, there is no change of fan speed for 20 seconds.
- (iii) Range of the outdoor fan speed under this control is as follows.
  - 1) Lower limit: 130min<sup>-1</sup>
  - 2) Upper limit: 500min<sup>-1</sup>
- (iv) As any of the following conditions is established, this control terminates.
  - 1) When the outdoor air temperature is in the zone (A) and the outdoor heat exchanger temperature at 30°C or higher is established for 40 seconds or more continuously.
  - 2) When the outdoor fan speed is 500min<sup>-1</sup> and the outdoor heat exchanger temperature at 30°C or higher is established for 40 seconds or more continuously.
  - 3) When the outdoor heat changer temperature at 45°C (model FDC250:50°C) or higher is established for 40 seconds or more.

**(e) Caution at the outdoor fan start control**

When the outdoor fan is running at  $400\text{min}^{-1}$  before operating the compressor, it may operate with the compressor only, without starting up the outdoor fan. This is normal.

**(f) Snow protection fan control**

If the DIP switch (SW3-2) on the outdoor unit control PCB is turned ON, the outdoor fan is operated for 30 seconds at 4 tap speed once in every 10 minutes depending on the outdoor air temperature (detected with Tho-A) in the stop mode or anomalous stop mode.

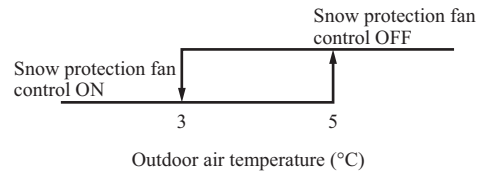

**(5) Defrost operation**

**(a) Starting conditions**

If all of the following defrost conditions A or conditions B are satisfied, the defrost operation starts.

**(i) Defrost conditions A**

- 1) Cumulative compressor operation time after the end of defrost operation has elapsed 37 minutes, and the cumulative compressor operation time after the start of heating operation (remote control ON) has elapsed 30 minutes.
- 2) After 5 minutes from the compressor ON
- 3) After 5 minutes from the start of outdoor fan
- 4) After satisfying all above conditions, if temperatures of the outdoor heat exchanger temperature sensor (Tho-R1, R2) and the outdoor air temperature sensor (Tho-A) become lower than the defrost operation start temperature as shown by the right figure for 15 seconds continuously, or the suction gas saturation temperature (SST) and the outdoor air temperature (Tho-A), which are obtained from the value detected by the low pressure sensor (PSL) stay for 3 minutes within the range below the defrost operation start temperature as shown by the right figure. However, it excludes for 10 minutes after the start of compressor and the outdoor air temperature is as shown by the lower figure.

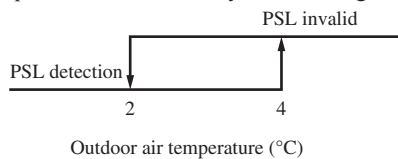
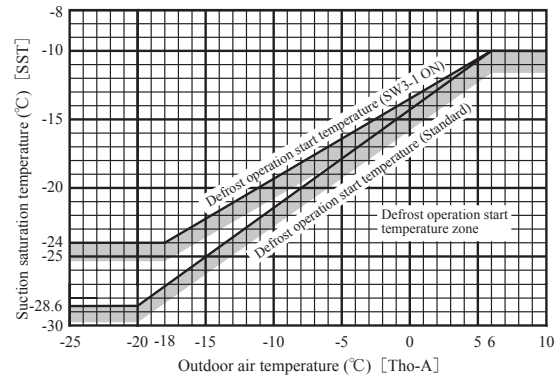
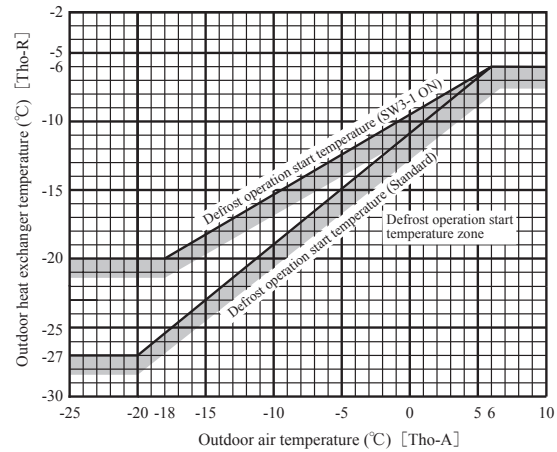

**(ii) Defrost conditions B**

- 1) When previous defrost ending condition is the time out of defrost operation and it is in the heating operation after the cumulative compressor operation time after the end of defrost operation has become 30 minutes.
- 2) After 5 minutes from the start of compressor.
- 3) After 5 minutes from the start of outdoor fan.

**(b) Ending conditions**

When any of the following conditions is satisfied, the heating operation starts.

- (i) When it has elapsed 8 minutes and 20 seconds after the start of defrost operation. (After 10 minutes and 20 seconds for FDC250 model)
- (ii) When the outdoor heat exchanger temperatures (Tho-R1, R2), whichever the lower, becomes 16 (FDC250:12)°C or higher for 10 seconds continuously.

**(c) Switching of defrost control with SW3-1**

- (i) If SW3-1 on the outdoor unit control PCB is turned to ON, it becomes easier to enter the defrost operation. Use this when installing a unit at snowing regions.
- (ii) Control contents
  - 1) It allows entering the defrost operation under the defrost condition A when the cumulative heating operation time becomes 30 minutes. It is 37 minutes at SW3-1 OFF (Factory default).
  - 2) It allows entering the defrost operation under the defrost condition B when the cumulative heating operation time becomes 25 minutes. It is 30 minutes at SW3-1 OFF (Factory default).
  - 3) It allows the defrost operation with the outdoor heat exchanger temperature (Tho-R) and suction pressure saturation temperature (SST) being higher than normal.

**(6) Protective control/anomalous stop control by compressor's number of revolutions**

**(a) Compressor discharge pipe temperature protection**

(i) Protective control

As the discharge pipe temperature (detected with Tho-D) exceeds the setting value, the compressor speed (frequency) is controlled to suppress the rise of discharge pipe temperature.

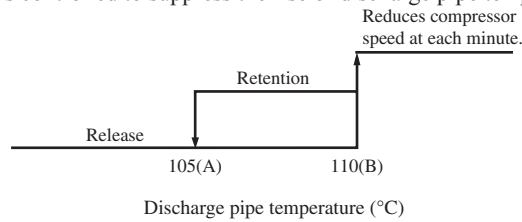

Note (1) Value in ( ) are for the model FDC200.

Super heat	A	B
25°C or more	95	100
20°C or less	100	105

(ii) Anomalous stop control

- 1) If the discharge pipe temperature (detected with Tho-D) exceeds the setting value, the compressor stops.
- 2) When it is detected 2 times within 60 minutes or after continuous 60 minutes, including the stop of compressor, E36 is displayed on the remote control and it enters the anomalous stop mode.

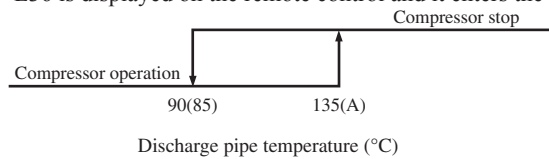

Note (1) Value in ( ) are for the model FDC200.

Super heat	A
25°C or more	110
20°C or less	115

(iii) Reset of anomalous stop mode

As it drops to the reset value of 90 (85)°C or lower for 45 minutes continuously, it becomes possible to restart from the remote control.

**(b) Cooling high pressure protection**

(i) Protective control

- 1) Outdoor heat exchanger temperature (Tho-R) exceeds the setting value A.
- 2) When the outdoor air temperature (Tho-A) is 40°C or higher and the outdoor heat exchanger temperature (Tho-R) exceeds certain value (depends on compressor frequency).
- 3) Control value A is updated to an optimum value automatically according to the operating conditions.

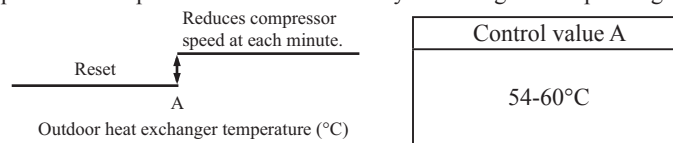

(ii) Anomalous stop control

- 1) As the outdoor heat exchanger temperature (Tho-R) exceeds the setting value, the compressor stops.
- 2) If it is detected 5 times within 60 minutes or 65°C or higher continues for 60 minutes, including the stop of compressor, E35 is displayed on the remote control and it enters the anomalous stop mode.

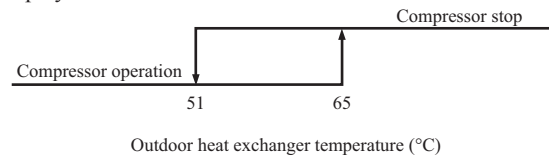

(iii) Reset of anomalous stop mode

As it reaches the reset value of 51°C or lower, it becomes possible to restart from the remote control.

**(c) Heating high pressure protection**

- (i) Protective control
  - 1) As the indoor heat exchanger temperature (Thi-R) exceeds the setting value, the compressor speed (frequency) is controlled to suppress the rise of high pressure.
  - 2) Control value A is updated to an optimum value automatically according to the operating conditions.

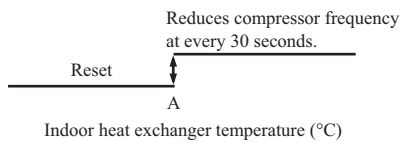

Model	Existing piping adaptation switch: SW5-1	
	OFF (Shipping)	ON
	Control value A (°C)	
FDC200	48-54	46-52
FDC250	52-58	

Note (1) Adaptation to existing piping is at ON.

- (ii) Anomalous stop control  
Operation control function by the indoor unit control - See the heating overload protection, page 18.
- (iii) Adaptation to existing piping, stop control  
If the existing piping adaptation switch, SW5-1, is turned ON, the compressor stops to protect existing piping when the indoor heat exchanger temperature (Thi-R) exceeds the setting value.

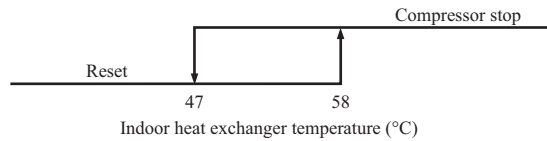

**(d) Anomaly detection control by the high pressure switch (63H1)**

- (i) If the pressure rises and operates the high pressure switch (opens at 4.15MPa/closes at 3.15MPa), the compressor stops.
- (ii) Under any of the following conditions, E40 is displayed and it enters the anomalous stop mode.
  - 1) When it occurs 5 times within 60 minutes that pressure rises and the compressor is stopped by 63H1.
  - 2) When 63H1 has been in the open state for 60 minutes continuously, including the stop of compressor.

**(e) Low pressure control**

- (i) Protective control  
If the value detected by the low pressure sensor (PSL) exceeds the setting value, the compressor speed (frequency) is controlled to restrain the drop of pressure.

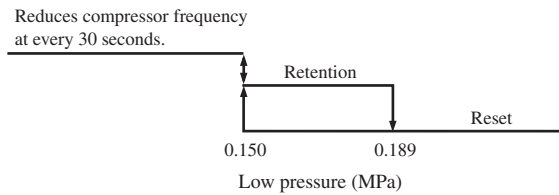

- (ii) Anomalous stop control
  - 1) When a value detected by the low pressure sensor (PSL) satisfies any of the following conditions, the compressor stops for its protection.
    - a) When the low pressure drops to 0.079MPa or under for 15 seconds continuously.
    - b) At 10 minutes after the start of compressor, the suction overheat becomes 30°C and the low pressure becomes 0.15MPa or under for 60 seconds continuously.
  - 2) E49 is displayed under any of the following conditions and it enters the anomalous stop mode.
    - a) When the low pressure drops 5 times within 60 minutes and the compressor stops under any of the above conditions.
    - b) When a value detected with the low pressure sensor becomes 0.079MPa or under for 5 minutes, including the stop of compressor.
  - 3) However, when the control condition 1). a) is established during the compressor protection start III, E49 is displayed at initial stop and it enters the anomalous stop mode.

**(f) Compressor pressure ratio protection control**

- (i) During heating operation, if the indoor heat exchanger temperature (Thi-R) and low pressure sensor (PSL) exceed the setting values at 10 minutes after the start of compressor, the compressor speed (frequency) is controlled to protect the compressor.
- (ii) This control is not performed during the outdoor fan ON and for 10 minutes from the start of outdoor fan.
- (iii) This control is not performed during defrost operation and at 10 minutes after the reset of defrost operation.
- (iv) When there are 3 indoor heat exchanger temperatures (Thi-R), the highest temperature is detected.

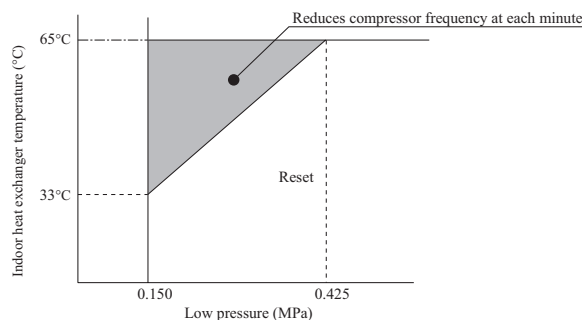

**(g) Over-current protection current safe controls I, II**

Detecting the outdoor inverter input (primary) current and the output (secondary) current, if the current values exceed setting values, the compressor speed (frequency) is controlled to protect the inverter.

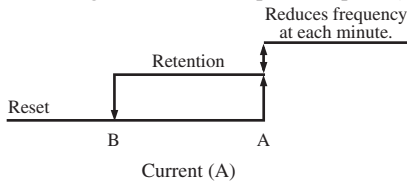

Model	Cooling		Heating	
	Control value A	Reset value B	Control value A	Reset value B
Primary current side	FDC200	16.0	15.0	16.0
	FDC250	18.0	17.0	18.0
Secondary current side	FDC200	15.5	14.5	15.5
	FDC250	17.0	16.0	17.0

**(h) Power transistor temperature protection (model FDC250 only)**

**(i) Protective control**

If the power transistor temperature (detected with TIP) exceeds the setting value, the compressor speed (frequency) is controlled to suppress the rise of power transistor temperature.

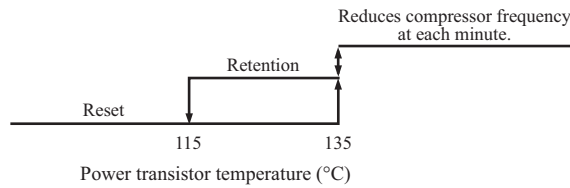

**(ii) Anomalous stop control**

- 1) If the power transistor temperature increases further, the protective switch in the power transistor trips and stops the compressor to protect the power transistor.
- 2) It enters the anomalous stop mode depending on one of the following conditions.
  - a) When the protective switch in the power transistor trips and stops the compressor 5 times within 60 minutes (Displays E41.)
  - b) When the protective switch in the power transistor trips and the state continues for 15 minutes, including the stop of compressor (Displays E51.)

**(iii) Anomalous inverter PCB**

- 1) If the power transistor detects anomaly 5 times within 60 minutes with compressor stop, E41 is displayed on the remote control and it enters the anomalous stop mode.
- 2) If the power transistor detects any anomaly for 15 minutes, including the stop of compressor, E51 is displayed on the remote control and it enters the anomalous stop mode.

**(i) Anomalous power transistor current**

- (i) Prevents over-current on the inverter. If the current value in the power transistor exceeds the setting value, the compressor stops.
- (ii) If the current value in the power transistor exceeds the specified value and the compressor stops 4 times within 30 minutes, E42 is displayed on the remote control and it enters the anomalous stop mode.

**(j) Anomalous inverter communication**

If the power transistor detects anomalies 4 times within 15 minutes, including the stop of compressor, E45 is displayed on the remote control and it enters the anomalous stop mode.

**(k) Anti-frost control by the compressor frequency control**

- (i) If the indoor heat exchanger temperature (detected with Thi-R) exceeds the setting value at 4 minutes after the start of compressor, the compressor speed (frequency) is controlled to initiate the anti-frost control of indoor heat exchanger.
- (ii) When there are 3 indoor heat exchanger temperatures (Thi-R), the lowest temperature is detected.

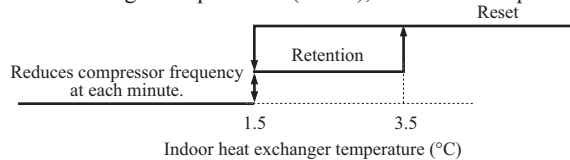

- (iii) Regarding the anti-frost control by the operation stop, refer to the operation control function by the indoor control and the cooling, dehumidifying frost prevention of page 18.

**(l) Dewing prevention control**

[Control condition]

During cooling and dehumidifying operation, if all the following conditions are established, the compressor speed (frequency) is reduced to prevent dewing and water splash.

- (i) Cooling electronic expansion valve aperture (EEVC) is 500 pulses.
- (ii) Suction overheat is 10°C or higher.
- (iii) Compressor speed (frequency) is **A** rps or higher.

[Control contents]

- (i) When the suction overheat is 10°C or higher, the compressor speed (frequency) is reduced at each 1 minute.
- (ii) Compressor speed (frequency) does not rise till the cooling expansion valve becomes 460 pulses.
- (iii) This control takes **A** rps as its lower limit so that compressor speed is not controlled when it is less than **A** rps.

Model	<b>A</b> rps
FDC200	60
FDC250	60

**(m) Refrigerant quantity shortage protection**

Under the compressor protection start III control during cooling and dehumidifying operations, the following control is performed by detecting the indoor heat exchanger temperature (Thi-R) and the indoor return air temperature (Thi-A).

[Control condition]

When the state that the indoor heat exchanger temperature (Thi-R) does not become lower than the indoor return air temperature (Thi-A) by 4°C or more continues for 1 minute.

[Control contents]

It judges that the flowing of refrigerant into the indoor unit is insufficient so that the compressor is stopped and E57 is displayed on the remote control.

**(n) Broken wire detection on temperature sensor and low pressure sensor**

- (i) Outdoor heat exchanger temperature sensor, outdoor air temperature sensor and low pressure sensor  
If the following is detected for 5 seconds continuously within 2 minutes to 2 minutes and 20 seconds after the compressor ON, the compressor stops. After a delay of 3 minutes, it restarts but, if the same is detected repeatedly 3 times within 40 minutes, the compressor stops with the anomalous stop.

Note (1) During defrost operation and for 3 minutes after the end of defrost operation, it is not detected.

- Outdoor heat exchanger temperature sensor: -50°C or lower
- Outdoor air temperature sensor: -45°C or lower
- Low pressure sensor: 0V or under or 4.0V or over

- (ii) Discharge pipe temperature sensor, suction pipe temperature sensor, compressor under dome temperature sensor  
If the following is detected for 5 seconds continuously within 10 minutes to 10 minutes and 20 seconds after the compressor ON, the compressor stops. After a delay of 3 minutes, it restarts but, if the same is detected repeatedly 3 times within 40 minutes, the compressor stops with the anomalous stop.

Note (1) During defrost operation and for 3 minutes after the end of defrost operation, it is not detected.

- Discharge pipe temperature sensor: -10°C or lower
- Suction pipe temperature sensor: -50°C or lower
- Compressor under dome temperature sensor : -50°C or lower

**(o) Fan motor error**

- (i) If the fan speed of 100min<sup>-1</sup> or under is detected for 30 seconds continuously under the outdoor fan control (with the operation command of fan tap at ① speed or higher), the compressor stops.
- (ii) When the fan motor speed drops to 100min<sup>-1</sup> or under 5 times within 60 minutes and the compressor stops, it enters the anomalous stop mode with E48 displayed on the remote control.

**(p) Anomalous stop by the compressor start stop**

- (i) When it fails to shift to the compressor DC motor's rotor position deflection operation at 5 seconds after establishing the compressor start condition, the compressor stops temporarily and restarts 3-minute later.
- (ii) If it fails to shift to the position detection operation again 20 times, it judges the anomalous compressor start and stops the compressor by the anomalous stop (E59).



**(7) Silent mode**

- (a) As “Silent mode start” signal is received from the remote control, it operates by dropping the outdoor fan tap and the compressor speed (frequency).
- (b) For details, refer to items (1) and (4) above.

**(8) Test run**

- (a) It is possible to operate from the outdoor unit using the DIP switch on the outdoor unit control PCB.

SW3-3	ON	SW3-4	OFF	Cooling test run
			ON	Heating test run
	OFF	Normal and end of test run		

Make sure to turn SW3-3 to OFF after the end of operation.

**(b) Test run control**

- (i) Operation is performed at the maximum compressor speed (frequency), which is determined for each model.
- (ii) Each protective control and error detection control are effective.
- (iii) If SW3-4 is switched during test run, the compressor is stopped once by the stop control and the cooling/heating operation is switched.
- (iv) Setting and display of remote control during test run

Mode \ Item	Contents of remote control setting/display
Cooling test run	Setting temperature of cooling is 5°C.
Heating test run	Setting temperature of heating (preparation) is 30°C.

**(9) Pump-down control**

Turning ON the pump-down switch SW1 for 2 seconds during the operation stop or anomalous stop (excluding the thermostat OFF), the pump-down operation is performed. (This is invalid when the indoor unit is operating. This is effective even when the indoor unit is stopped by the anomalous stop or the power source is turned OFF.)

**(a) Control contents**

- (i) Close the service valve at the liquid side. (It is left open at the gas side.)
- (ii) Compressor is started with the target speed (frequency) at FDC200:45, FDC250:55 rps in the cooling mode.
- (iii) Red and green lamps (LED) keeps flashing on the outdoor unit control PCB.
- (iv) Each of protection and error detection controls, excluding the low pressure control, anti-frost control and dewing prevention control, is effective.
- (v) Outdoor fan is controlled as usual.
- (vi) Electronic expansion valve is fully opened.

**(b) Control ending conditions**

Stop control is initiated depending on any of the following conditions.

- (i) Low pressure of 0.087MPa or lower is detected for 5 seconds continuously.
  - 1) Red LED: Light, Green LED: keeps flashing, Remote control: Displays stop.
  - 2) It is possible to restart when the low pressure is 0.087MPa or higher.
  - 3) Electronic expansion valve (cooling/heating) is kept fully open.
- (ii) Stop by the error detection control
  - 1) Red LED: keeps flashing, Green LED: keeps flashing
  - 2) Restart is prohibited. To return to normal operation, reset the power source.
  - 3) Electronic expansion valve (cooling/heating) is left fully open.
- (iii) When the cumulative operation time of compressor under the pump-down control becomes 5 minutes.
  - 1) Red LED: stays OFF, Green LED: keeps flashing, Remote control: Stop
  - 2) It is possible to pump-down again.
  - 3) Electronic expansion valve (cooling/heating) is left fully open.

Note (1) After the stop of compressor, close the service valve at the gas side.

Caution: Since pressing the pump-down switch cancels communications with the indoor unit, the indoor unit and the remote control display “Transmission error – E5”. This is normal.

**(10) Base heater ON/OFF output control (Option)**

**(i) Base heater ON conditions**

When all of following conditions are satisfied, the base heater is turned ON.

- Outdoor air temperature (detected with Tho-A) is 1°C or lower.
- In the heating mode
- When the compressor is turned ON

**(ii) Base heater OFF conditions**

When either one of following conditions is satisfied, the base heater is turned OFF.

- Outdoor air temperature (detected with Tho-A) is 3°C or higher.
- When the compressor stop has been detected for 30 minutes continuously
- In the cooling or dehumidifying mode

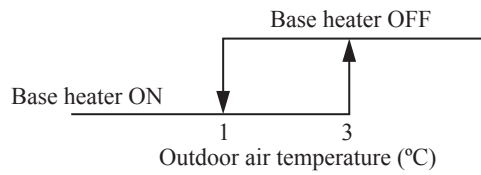

## 2.2 MAINTENANCE DATA

See page 40 of 1.2 chapter.

# 2.3 ELECTRICAL WIRING

- (1) Indoor units ..... See page 166.
- (2) Outdoor units  
Models FDC100VNA, 125VNA, 140VNA

Item	Description
CH	Crankcase heater
CM	Compressor motor
CN	Connector
CT1	Current sensor
DH	Drain pan heater
EEVC	Expansion valve for cooling
EEVH	Expansion valve for heating
F	Fuse
FM1	Fan motor
IPM	Intelligent power module
LED1	Indication lamp (GREEN)
LED2	Indication lamp (RED)
L1,2	Reactor
SW1	Switch
SW3,5,7	Local setting switch
TB	Terminal block
Tho-A	Temperature sensor (Outdoor air)
Tho-D	Temperature sensor (Discharge pipe)
Tho-R1,R2	Temperature sensor (Heat exchanger)
Tho-S	Temperature sensor (Suction pipe)
20S	Solenoid valve for 4-way valve
52X1	Auxiliary relay
52X3	Auxiliary relay
52X11	Auxiliary relay (for 20S)
52X14	Auxiliary relay (for CH)
52X15	Auxiliary relay (for DH)
63H1	High pressure switch

Color	Mark
Black	BK
Blue	BL
Brown	BR
Green	GN
Orange	OR
Red	RD
White	WH
Yellow	Y
Yellow/Green	Y/GN

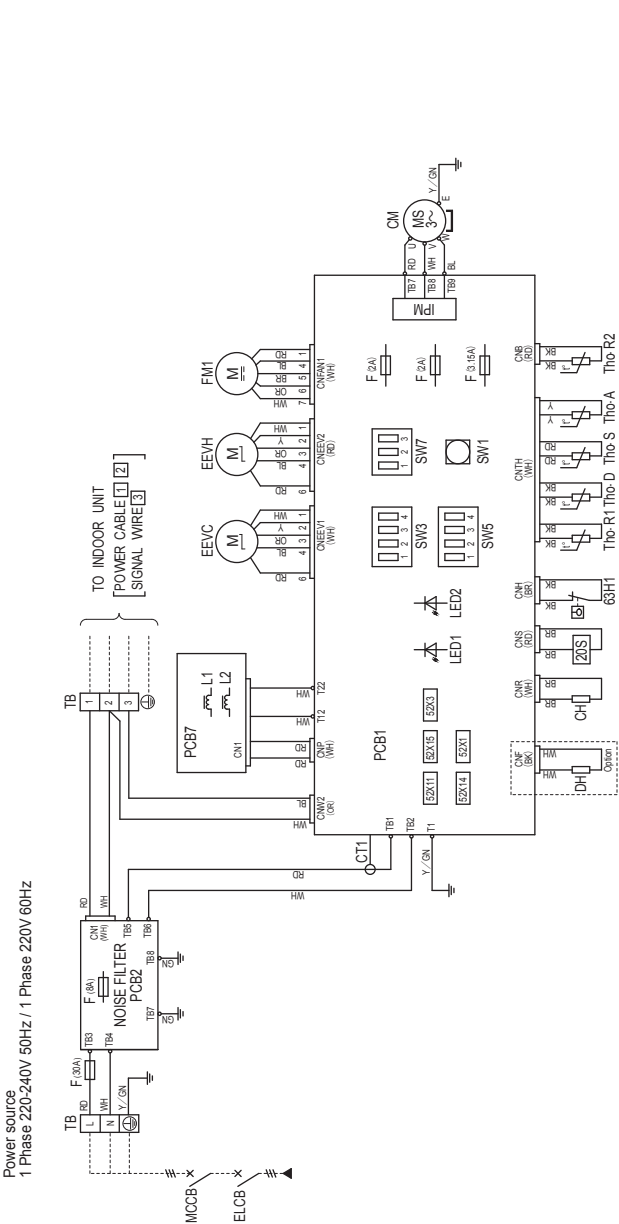

Local setting switch SW3,5,7 (Set up at shipment OFF)

SW3-1	Defrost control change
SW3-2	Snow guard fan control
SW3-3,4	Trial operation
SW5,2	High height difference operation control
SW7-2	Defrost control change
SW7-3	Lower noise silent mode

The defrosting operation interval becomes shorter by turning ON this switch. This switch should be turned ON in the area where outside temperature becomes below the freezing point.

When this switch is turned ON, the outdoor unit fan will run for 10 seconds in every 10 minutes, when outdoor temperature falls to 3°C or lower and the compressor is not running when the unit is used in a very snowy country, set this switch to ON.

Method of trial operation

- ① Trial operation can be performed by using SW3,3,4.
- ② Compressor will be in the operation when SW3,3 is ON.
- ③ Cooling trial operation will be performed when SW3,4 is OFF and heating trial operation when SW3,4 is ON.
- ④ Be sure to turn OFF SW3,3 after the trial operation is finished.

Set this switch to ON when outdoor unit is installed at a position higher than indoor unit by 30m or more.

Set this switch to ON when managing unit operation by remote control connected external equipment.

Upper limit of compressor speed and fan speed becomes lower in silent mode.

Model	MAX over current (A)	Power cable size (mm <sup>2</sup> )	Power cable length (m)	Indoor-outdoor wire size x number	Earth wire size (mm)
100	24	5.5	22	φ 1.6mm x 3	φ 1.6
125	26	5.5	20	φ 1.6mm x 3	φ 1.6
140	27	5.5	20	φ 1.6mm x 3	φ 1.6

※At the connection with the duct type indoor unit.

- The specifications shown in the above table are for units without heaters. For units with heaters, refer to the installation instructions or the construction instructions of the indoor unit.
- Switchgear or Circuit breaker capacity which is calculated from MAX. over current should be chosen along the regulations in each country.
- The cable specifications are based on the assumption that a metal or plastic conduit is used with no more than three cables contained in a conduit and a voltage drop is 2%. For an installation falling outside of these conditions, please follow the internal cabling regulations. Adapt it to the regulation in effect in each country.

PCA001Z817

Models FDC100VSA, 125VSA, 140VSA

Meaning of marks

Item	Description
CH	Crankcase heater
CM	Compressor motor
CN	Connector
DH	Drain pan heater
EEVC	Expansion valve for cooling
EEVH	Expansion valve for heating
F	Fuse
FM1	Fan motor
IPM	Intelligent power module
L	Reactor
LED1	Indication lamp (GREEN)
LED2	Indication lamp (RED)
SW1	Switch
SW3.5.7	Local setting switch
TB	Terminal block
Tho-A	Temperature sensor (Outdoor air)
Tho-D	Temperature sensor (Discharge pipe)
Tho-R1,R2	Temperature sensor (Heat exchanger)
Tho-S	Temperature sensor (Suction pipe)
20S	Solenoid valve for 4-way valve
52X1	Auxiliary relay
52X2	Auxiliary relay
52X6	Auxiliary relay (for FM1)
52X11	Auxiliary relay (for 20S)
52X14	Auxiliary relay (for CH)
52X15	Auxiliary relay (for DH)
63H1	High pressure switch

Mark	Color
BK	Black
BL	Blue
BR	Brown
GN	Green
OR	Orange
RD	Red
WH	White
Y	Yellow
Y/GN	Yellow/ Green

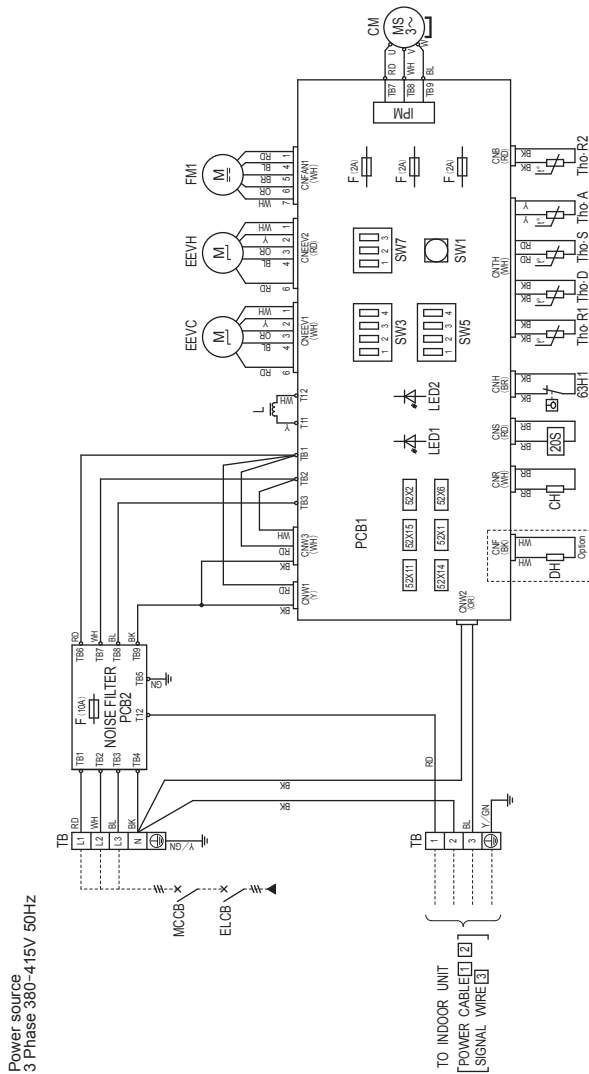

Local setting switch SW3.5.7 (Set up at shipment OFF)

Item	Description
SW3-1	Defrost control change
SW3-2	Snow guard fan control
SW3-3,4	Trial operation
SW5-2	High height difference operation control
SW7-2	Defrost control change
SW7-3	Lower noise silent mode

Power cable, indoor-outdoor connecting wires				
Model	MAX over current (A)	Power cable size (mm <sup>2</sup> )	Power cable length (m)	
100	15	3.5	Indoor-outdoor wire size x number	
125			46	φ 1.6mm x 3
140			46	φ 1.6
※At the connection with the ducttype indoor unit.				
Model	MAX over current (A)	Power cable size (mm <sup>2</sup> )	Power cable length (m)	
100	17	3.5	Indoor-outdoor wire size x number	
125			40	φ 1.6mm x 3
140			38	φ 1.6

- The specifications shown in the above table are for units without heaters. For units with heaters, refer to the installation instructions or the construction instructions of the indoor unit.
- Switchgear of Circuit breaker capacity which is calculated from MAX. over current should be chosen along the regulations in each country.
- The cable specifications are based on the assumption that a metal or plastic conduit is used with no more than three cables contained in a conduit and a voltage drop is 2%. For an installation falling outside of these conditions, please follow the internal cabling regulations. Adapt it to the regulation in effect in each country.

PCA001Z818

Model FDC200VSA

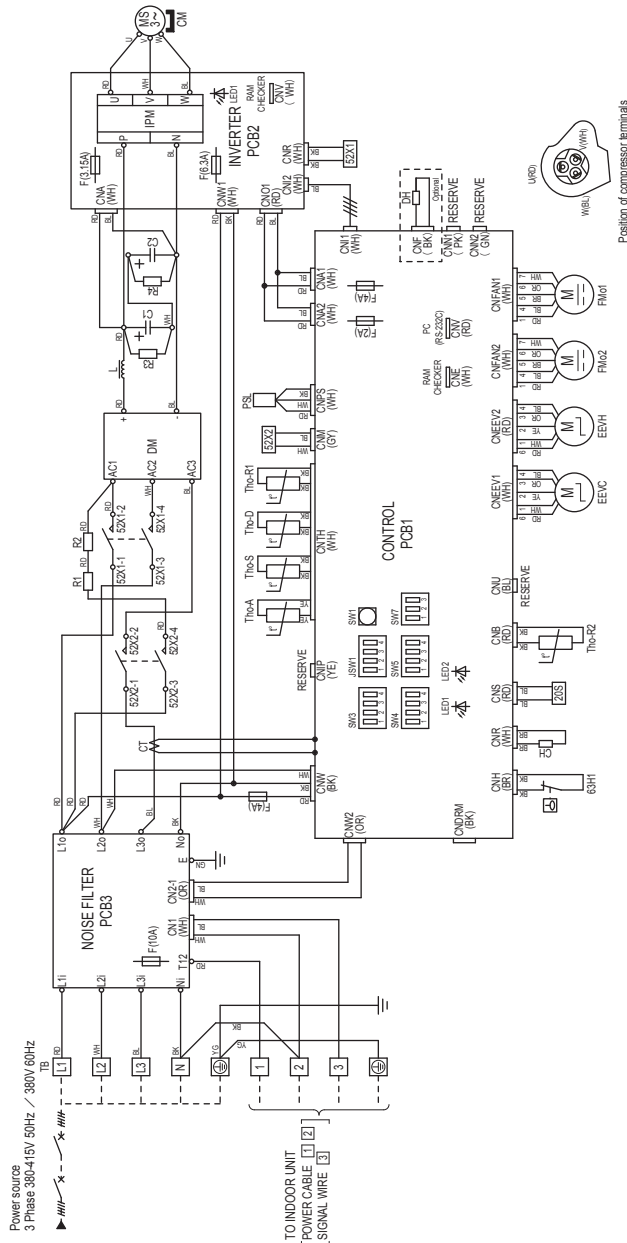

Meaning of marks

Mark	Parts name
CH	Criticase heater
CM	Compressor motor
CNA-Z	Connector
CT	Current sensor
DH	Drain pan heater
DM	Diode module
F	Fuse
FMot.2	Fan motor
IPM	Intelligent power module
L	Reactor
LED1	Indication lamp (GREEN)
LED2	Indication lamp (RED)
PSL	Low pressure sensor
EEVC	Expansion valve for cooling
EEVH	Expansion valve for heating
SW1	Pump down switch
SW3-5,7	Local setting switch
TB	Terminal block
Tho-A	Temperature sensor (Outdoor air)
Tho-D	Temperature sensor (Discharge pipe)
Tho-R1, R2	Temperature sensor (Heat exchanger)
Tho-S	Temperature sensor (Suction pipe)
20S	Solenoid coil for 4-way valve
52X1, 2	Relay
63H1	High pressure switch

Color marks

Mark	Color
BK	Black
BL	Blue
BR	Brown
GN	Green
OR	Orange
RD	Red
WH	White
YE	Yellow
YG	Yellow/Green
GY	Gray
PK	Pink

Local setting switch SW3 ( Set up at shipment OFF)

SW3-1	Defrost control change	The defrosting operation interval becomes shorter by turning ON this switch. This switch should be turned ON in the area where outside temperature becomes below the freezing point.
SW3-2	Snow guard fan control	When this switch is turned ON, the outdoor unit fan will run for 30 seconds in every 10 minutes, when outdoor temperature falls to 3°C or lower and the compressor is not running when the unit is used in a very snowy country, set this switch to ON.
SW3-3,4	Trial operation	Method of trial operation ① Trial operation can be performed by using SW3-3,4. ② Compressor will be in the operation when SW3-3 is ON. ③ Cooling trial operation will be performed when SW3-4 is OFF, and heating trial operation when SW3-4 is ON. ④ Be sure to turn OFF SW3-3 after the trial operation is finished.

Power cable, indoor-outdoor connecting wires

MAX over current (A)	Power cable size (mm)	Indoor-outdoor wire size x number	Earth wire size
25	5.5	φ1.6mm x 3	φ1.6mm

- The specifications shown in the above table are for units without heaters. For units with heaters, refer to the installation instructions or the construction instructions of the indoor unit.
- Switchgear of circuit breaker capacity which is calculated from MAX. over current should be chosen along the regulations in each country
- The cable specifications are based on the assumption that a metal or plastic conduit is used with no more than three cables contained in a conduit and a voltage drop is 2%. For an installation falling outside of these conditions, please follow the internal cabling regulations. Adapt it to the regulation in effect in each country.

PCA001Z769

Model FDC250VSA

Meaning of marks

Mark	Parts name
CH	Crankcase heater
CM	Compressor motor
CNA-Z	Compressor
CT	Current sensor
DH	Drain pan heater
DM	Diode module
F	Fuse
FMo1,2	Fan motor
IPM	Intelligent power module
L	Reactor
LED1	Indication lamp (GREEN)
LED2	Indication lamp (RED)
PSL	Low pressure sensor
EEVC	Expansion valve for cooling
EEVH	Expansion valve for heating
SW1	Pump down switch
SW3-5,7	Local setting switch
TB	Terminal block
Tho-A	Temperature sensor (Outdoor air)
Tho-D	Temperature sensor (Discharge pipe)
Tho-R1,R2	Temperature sensor (Heat exchanger)
Tho-H	Temperature sensor (Compressor under dome)
Tho-S	Temperature sensor (Suction pipe)
20S	Solenoid coil for 4-way valve
SV6	Solenoid coil for 2-way valve
52X1, 2	Relay
63H1	High pressure switch

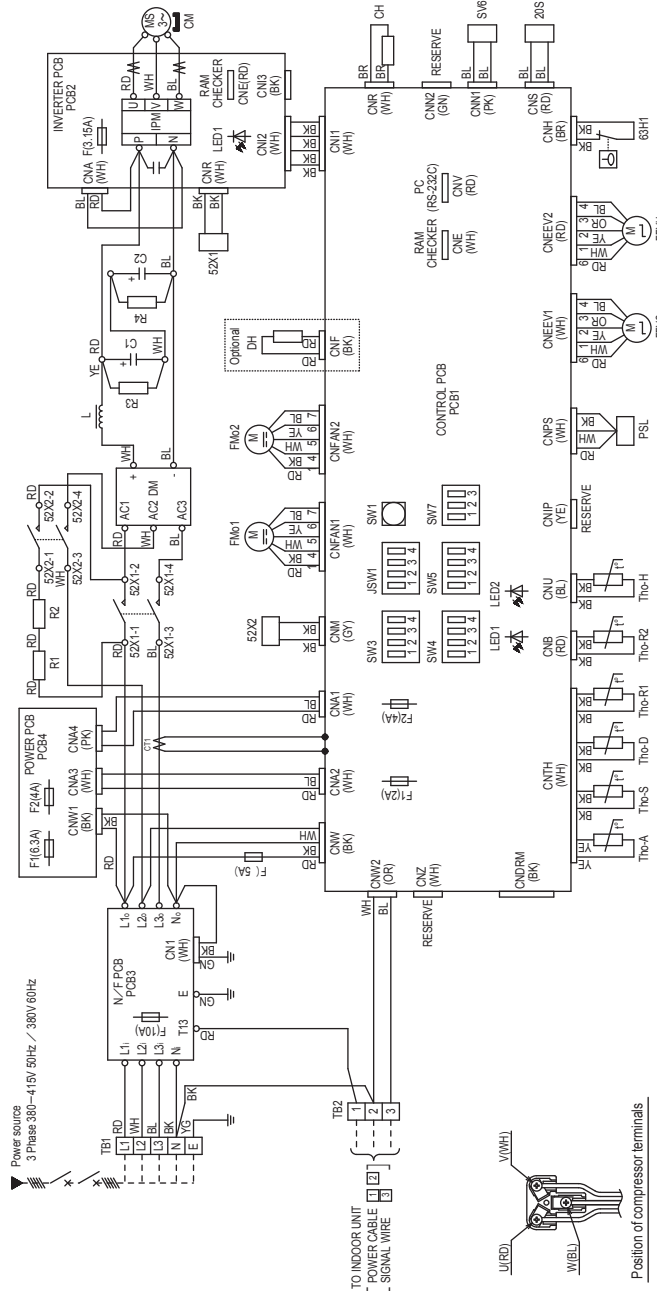

Color marks

Mark	Color
BK	Black
BL	Blue
BR	Brown
GN	Green
OR	Orange
RD	Red
WH	White
YE	Yellow
YG	Yellow/Green
GY	Gray
PK	Pink

Local setting switch SW3 (Set up at shipment OFF)

SW3-1	SW3-2	SW3-3,4
Defrost control change	Snow guard fan control	Trial operation

The defrosting operation interval becomes shorter by turning ON this switch. This switch should be turned ON in the area where outside temperature becomes below the freezing point.

When this switch is turned ON, the outdoor unit fan will run for 30 seconds in every 10 minutes, when outdoor temperature falls to 3°C or lower and the compressor is not running when the unit is used in a very snowy country, set this switch to ON.

Method of trial operation  
 ① Trial operation can be performed by using SW3-3,4.  
 ② Compressor will be in the operation when SW3-3 is ON.  
 ③ Cooling trial operation will be performed when SW3-4 is OFF, and heating trial operation when SW3-4 is ON.  
 ④ Be sure to turn OFF SW3-3 after the trial operation is finished.

Power cable, indoor-outdoor connecting wires

MAX over current (A)	Power cable size (mm²)	Power cable length (m)	Indoor-outdoor wire size x number	Earth wire size
27	5.5	40	φ 1.6mm x 3	φ 1.6mm

- The specifications shown in the above table are for units without heaters. For units with heaters, refer to the installation instructions or the construction instructions of the indoor unit.
- Switchgear of circuit breaker capacity which is calculated from MAX. over current should be chosen along the regulations in each country.
- The cable specifications are based on the assumption that a metal or plastic conduit is used with no more than three cables contained in a conduit and a voltage drop is 2%. For an installation falling outside of these conditions, please follow the internal cabling regulations. Adapt it to the regulation in effect in each country.

PCB003Z866

## 2.4 PIPING SYSTEM

### (1) Single type Models FDT100, 125, 140

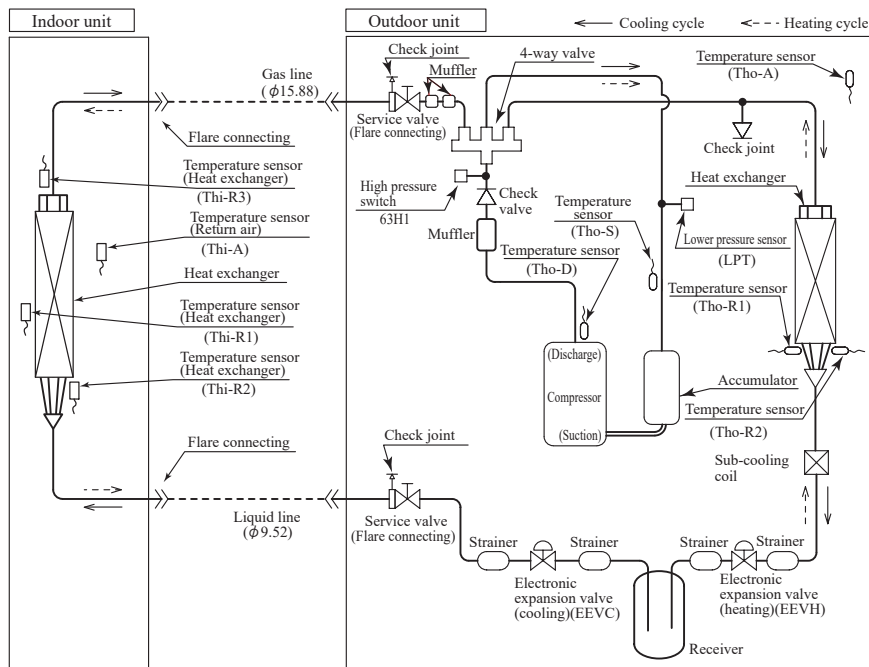

### (2) Twin type Models FDT140

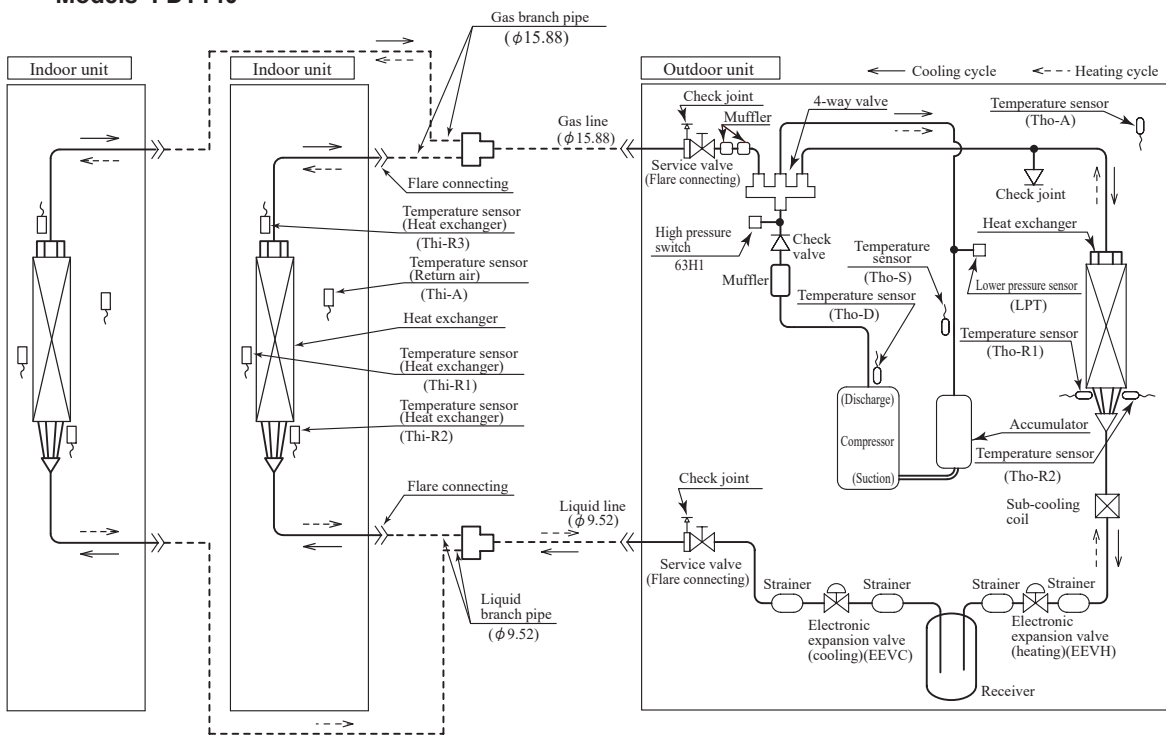

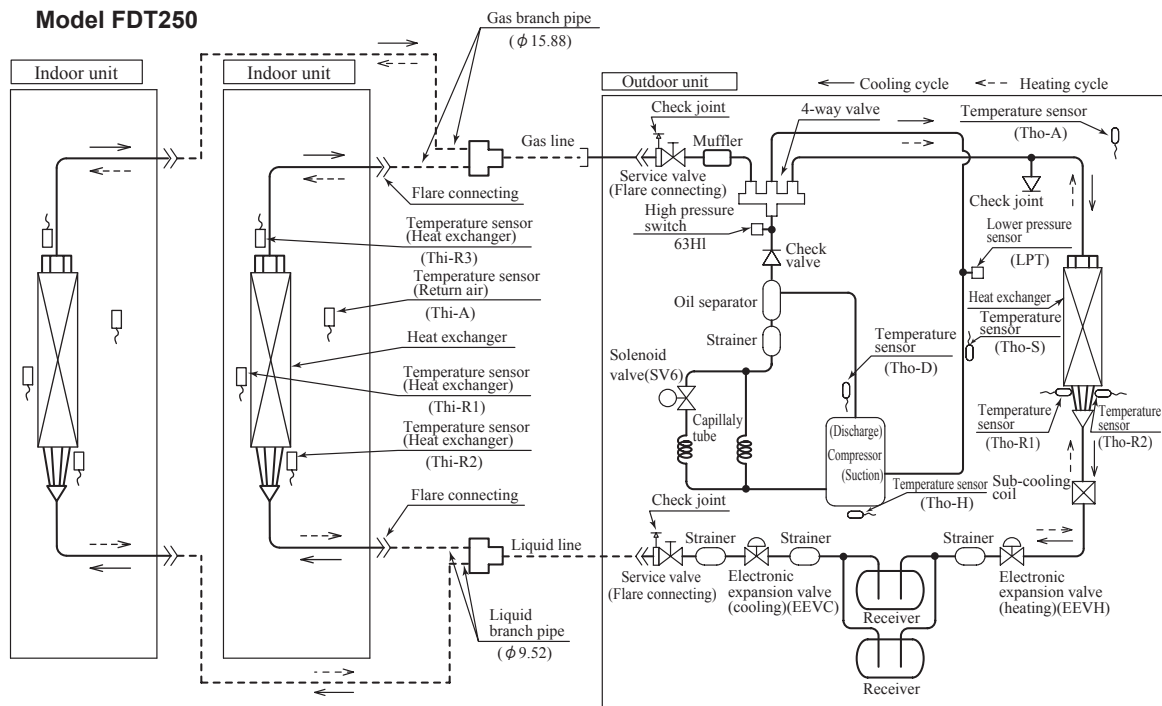
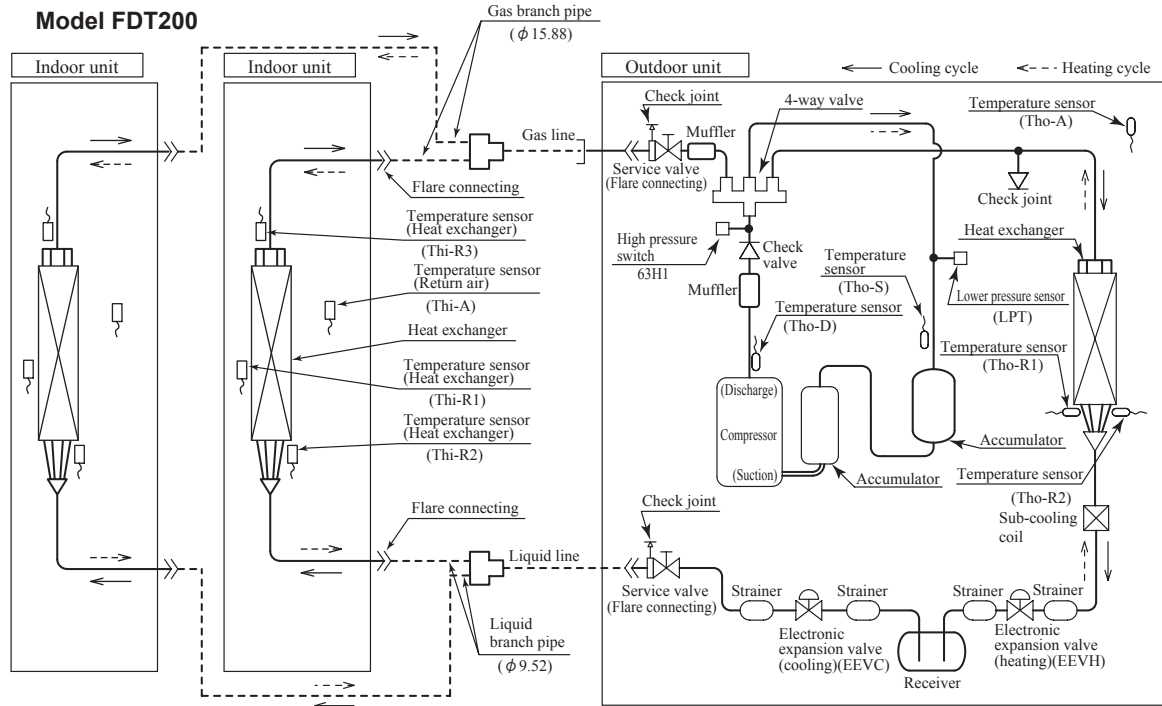

●Refrigerant line (one way) pipe size

Model	Gas line	Liquid line
FDT200	In case of $\phi$ 22.22 : 35m	In case of $\phi$ 9.52 : 40m In case of $\phi$ 12.7 : 70m
FDT250	In case of $\phi$ 25.4 or $\phi$ 28.58 : 70m	In case of $\phi$ 12.7 : 70m



**(3) Triple type  
Model FDT200**

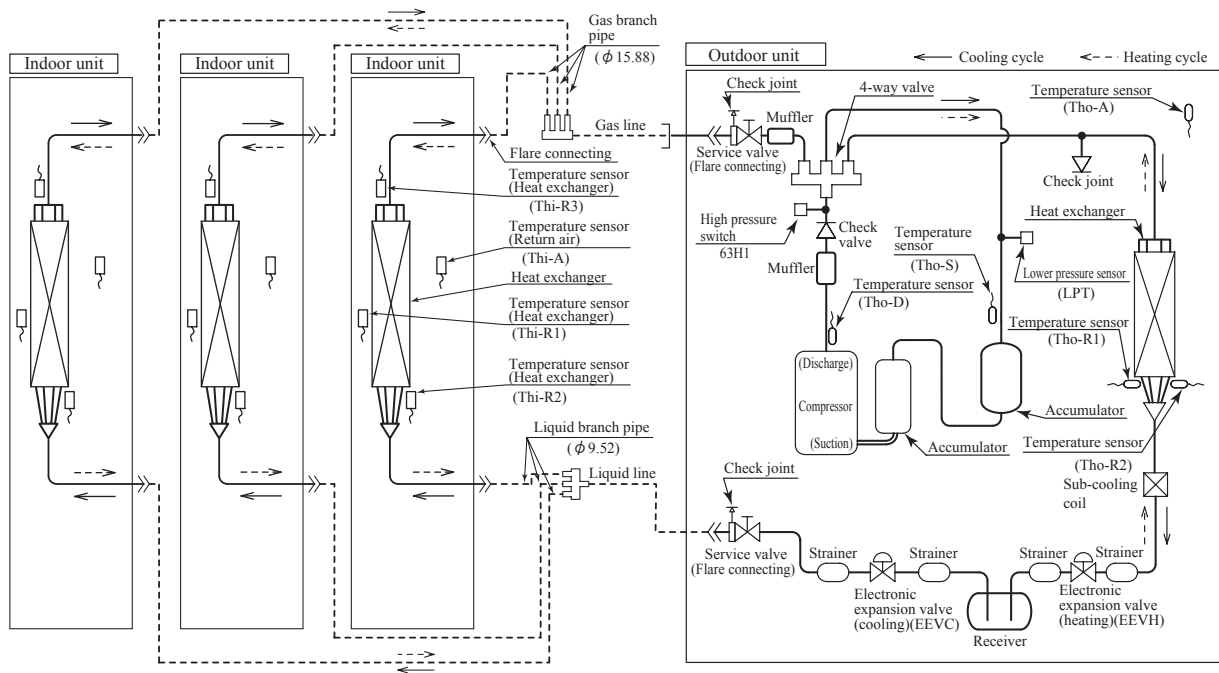

●Refrigerant line (one way) pipe size

Gas line	Liquid line
In case of $\phi$ 22.22 : 35m	In case of $\phi$ 9.52 : 40m
In case of $\phi$ 25.4 or $\phi$ 28.58 : 70m	In case of $\phi$ 12.7 : 70m

**Preset point of the protective devices**

Parts name	Mark	Equipped unit	FDT100, 125, 140 models	FDT200, 250 models
Temperature sensor (for protection overloading in heating)	Thi-R	Indoor unit	OFF 63°C ON 56°C	
Temperature sensor (for frost prevention)	Thi-R		OFF 1.0°C ON 10°C	
Temperature sensor (for protection high pressure in cooling)	Tho-R	Outdoor unit	OFF 51°C ON 65°C	
Temperature sensor (for detecting discharge pipe temperature)	Tho-D	Outdoor unit	OFF 115°C ON 85°C	OFF 135°C ON 90°C
High pressure switch (for protection)	63H1	Outdoor unit		OFF 4.15MPa ON 3.15MPa
Low pressure sensor (for protection)	LPT	Outdoor unit		OFF 0.227MPa ON 0.079MPa

### 3. STANDARD INVERTER PACKAGED AIR-CONDITIONERS

#### CONTENTS

<b>3.1 OUTLINE OF OPERATION CONTROL BY MICROCOMPUTER .....</b>	<b>202</b>
<b>3.1.1 Remote control (Option parts) .....</b>	<b>202</b>
<b>3.1.2 Operation control function by the wired remote control .....</b>	<b>202</b>
<b>3.1.3 Operation control function by the indoor control .....</b>	<b>202</b>
<b>3.1.4 Operation control function by the outdoor control .....</b>	<b>202</b>
<b>( I ) Models FDC71VNP, 90VNP1 .....</b>	<b>202</b>
(1) Compressor speed.....	202
(2) Compressor protection start.....	202
(3) Outdoor fan control .....	202
(4) Defrost operation .....	204
(5) Cooling overload protective control.....	205
(6) Cooling high pressure control .....	205
(7) Cooling low outdoor temperature protective control.....	205
(8) Heating high pressure control .....	206
(9) Heating overload protective control.....	206
(10) Heating low outdoor temperature protective control.....	207
(11) Compressor overheat protection .....	207
(12) Current safe .....	208
(13) Current cut .....	208
(14) Outdoor unit failure .....	208
(15) Serial signal transmission error protection.....	208
(16) Rotor lock .....	208
(17) Refrigeration cycle system protection.....	208
(18) Silent mode .....	208
(19) Broken wire detection on temperature sensor .....	209
<b>( II ) Model FDC100VNP .....</b>	<b>210</b>
(1) Compressor speed.....	210
(2) Compressor protection start.....	210
(3) Outdoor fan control .....	210
(4) Defrost operation .....	212
(5) Cooling overload protective control.....	213
(6) Cooling high pressure control .....	213
(7) Cooling low outdoor temperature protective control.....	213
(8) Heating high pressure control .....	214
(9) Heating overload protective control I .....	214
(10) Heating overload protective control II .....	214
(11) Heating low outdoor temperature protective control.....	215
(12) Compressor overheat protection .....	215
(13) Current safe .....	215

(14) Current cut.....	216
(15) Outdoor unit failure .....	216
(16) Serial signal transmission error protection .....	216
(17) Rotor lock .....	216
(18) Refrigeration cycle system protection .....	216
(19) Silent mode .....	216
(20) Broken wire detection on temperature sensor.....	217
(21) Base heater ON/OFF output control (Option) .....	217
(22) Reverse operation start for compressor protection .....	217
<b>3.2 MAINTENANCE DATA .....</b>	<b>217</b>
<b>3.3 ELECTRICAL WIRING.....</b>	<b>218</b>
(1) Indoor units .....	218
(2) Outdoor units .....	218
<b>3.4 PIPING SYSTEM .....</b>	<b>221</b>

### 3.1 OUTLINE OF OPERATION CONTROL BY MICROCOMPUTER

- 3.1.1 Remote control (option parts) ..... See page 4.
- 3.1.2 Operation control function by the wired remote control ..... See page 7.
- 3.1.3 Operation control function by the indoor control ..... See page 10.
- 3.1.4 Operation control function by the outdoor control

(I) Models FDC71VNP, 90VNP1

(1) Compressor speed

Unit: rps

Item \ Model	Cooling		Heating	
	FDC71	FDC90	FDC71	FDC90
Upper limit	120 (80)	120 (74)	120 (90)	120 (70)
Lower limit	12		12	

Note (1) Value in ( ) are for the silent mode.

(2) Compressor protection start

(a) Compressor protection start I

(i) Operating condition

When the compressor is turned ON from the state of OFF.

(ii) Detail of operation

During the protection start I control, the upper limit of compressor speed is restricted to the speeds as shown in the following table.

Unit: rps

		Time after establishment of operating conditions (Including acceleration time)					
		Less than 3 min	Less than 5 min	Less than 7 min	Less than 9 min	9 min or more	
FDC71	Cooling	120	120	120	120	End of control	
	Heating <sup>(1)</sup>	TH2 ≥ 10°C	120	120	120		120
		TH2 < 10°C	48	56	56		75
FDC90	Cooling	120	120	120	120		
	Heating <sup>(1)</sup>	TH2 ≥ 10°C	55	55	75		95
		TH2 < 10°C	55	55	75		95

Note (1) Judgment by the outdoor air temperature sensor (TH2) is made only at the start of control during heating operation.

(b) Compressor protection start II

(i) Operating condition

When the outdoor air temperature sensor (TH2) has detected lower than 10°C after starting the compressor during heating operation.

(ii) Detail of operation

During the protection start II control, the upper limit of compressor speed is restricted to the speeds as shown in the following table.

Unit: rps

		Time after compressor ON (Including acceleration time)				
		Less than 1 min	Less than 5 min	Less than 7 min	Less than 9 min	9 min or more
FDC71		40	32	90	110	End of control
FDC90	TH2 ≥ -5°C	40	32	90	110	
	TH2 < -5°C	40	45	90	110	

(3) Outdoor fan control

(a) Outdoor fan speed and fan motor speed

Unit: min<sup>-1</sup>

Fan speed	1st speed	2nd speed	3rd speed	4th speed	5th speed	6th speed	7th speed	8th speed
FDC71	150	225	485	520	570	685	800	850
FDC90	150	300	500	650	740	835	890	950

(b) Outdoor fan control at start (Cooling operation only)

When the outdoor air temperature (TH2) is lower than 22°C at the start of compressor, the outdoor fan is operated at a fixed speed.

- (i) When the outdoor air temperature is higher than 11°C, the compressor runs at 2nd speed for 30 seconds after the compressor ON.
- (ii) When the outdoor air temperature is lower than 11°C, the compressor runs at 1st speed for 30 seconds after the compressor ON.

- (c) Relationship between compressor speed and outdoor fan speed.  
Outdoor fan speed is controlled according to the operation mode (Heating/cooling) and the compressor speed.

Unit: rps

Fan speed		1st speed	2nd speed	3rd speed	4th speed	5th speed	6th speed	7th speed	8th speed
FDC71	Cooling	–	–	–	0-22	22-30	30-58	58-80	80-
	Heating	–	–	–	0-30	30-38	38-78	78-90	90-
FDC90	Cooling	–	–	0-30	30-46	46-64	64-70	70-75	75-
	Heating	–	–	0-30	30-46	46-70	70-90	90-	–

**(d) Outdoor fan control at low outdoor temperature**

**(i) Cooling**

**1) Operating conditions**

When the outdoor air temperature (TH2) is 22°C or lower continues for 30 seconds while the compressor speed is other than 0 rps.

**2) Detail of operation**

After the outdoor fan operates at A speed for 60 seconds; the corresponding outdoor heat exchanger temperature shall implement the following controls.

- Value of A

	Outdoor fan
Outdoor temperature > 10°C	12th speed
Outdoor temperature ≤ 10°C	9th speed

- Outdoor heat exchanger temperature ≤ 21°C  
After the outdoor fan speed drops (down) to 1 speed for 60 seconds; if the outdoor heat exchanger temperature is lower than 21°C, gradually reduce the outdoor fan speed by 1 speed. (Lower limit 9th speed)
- 21°C < Outdoor heat exchanger temperature ≤ 38°C  
After the outdoor fan speed maintains for 20 seconds; if the outdoor heat exchanger temperature is 21°C-38°C, maintain outdoor fan speed again.
- Outdoor heat exchanger temperature > 38°C  
After the outdoor fan speed rises (up) to 1 speed for 60 seconds; if the outdoor heat exchanger temperature is higher than 38°C, gradually increase outdoor fan speed by 1 speed. (Upper limit 15th speed)

**3) Reset conditions**

When either of the following conditions is satisfied.

- The outdoor air temperature (TH2) is 25°C or higher and fan speed is 15th speed.
- The compressor speed is 0 rps.

**4) Outdoor fan speed and fan motor speed**

Unit: min-1

Fan speed	9th speed	10th speed	11th speed	12th speed	13th speed	14th speed	15th speed
FDC71	150	175	200	225	305	385	485
FDC90	200	225	250	275	300	400	500

**(ii) Heating**

**1) Operating condition**

When the outdoor air temperature (TH2) is 4°C or lower continues for 30 seconds while the compressor speed is other than 0 rps.

**2) Detail of operation**

The outdoor fan is stepped up by 2 speed step at each 20 seconds. (Upper limit 8th speed)

**3) Reset conditions**

When either of the following conditions is satisfied.

- The outdoor air temperature (TH2) is 6°C or higher.
- The compressor speed is 0 rps.

**(e) Outdoor fan control at overload**

**(i) Cooling**

**1) Operating condition**

When the outdoor air temperature (TH2) is 41°C or higher continues for 30 seconds while the compressor command speed is other than 0 rps.

**2) Detail of operation**

The outdoor fan is stepped up by 3 speed. (Upper limit 8th speed)

**3) Reset conditions**

When either of the following conditions is satisfied.

- The outdoor air temperature (TH2) is 40°C or lower.
- The compressor speed is 0 rps.

(ii) Heating

1) Operating conditions

When the outdoor air temperature (TH2) is 13°C or higher continues for 30 seconds while the compressor speed is other than 0 rps.

2) Detail of operation

After the outdoor fan operates at -3 speed for 60 seconds; the corresponding outdoor heat exchanger temperature shall implement the following controls.

- a) Outdoor heat exchanger temperature  $\leq 10^{\circ}\text{C}$   
After the outdoor fan speed rises (up) to 1 speed for 60 seconds; if the outdoor heat exchanger temperature is lower than 10°C, gradually increase the outdoor fan speed by 1 speed.
- b)  $10^{\circ}\text{C} < \text{Outdoor heat exchanger temperature} \leq 13^{\circ}\text{C}$   
After the outdoor fan speed maintains for 20 seconds; if the outdoor heat exchanger temperature is 10°C-13°C, maintain outdoor fan speed again.
- c) Outdoor heat exchanger temperature  $> 13^{\circ}\text{C}$   
After the outdoor fan speed drops (down) to 1 speed for 60 seconds; if the outdoor heat exchanger temperature is higher than 13°C, gradually reduce outdoor fan speed by 1 speed. (Lower limit 2nd speed)

3) Reset conditions

When either of the following conditions is satisfied.

- a) The outdoor air temperature (TH2) is 11°C or lower.
- b) The compressor speed is 0 rps.

(f) Outdoor fan motor protection

If the outdoor fan motor has operated at 75 min<sup>-1</sup> or lower for more than 30 seconds, the compressor and fan motor are stopped.

(4) Defrost operation

(a) Starting conditions (Defrost operation can be started only when all of the following conditions are satisfied.)

- (i) After start of heating operation.  
When it elapsed 35 minutes. (Accumulated compressor operation time)
- (ii) After end of defrost operation.  
When it elapsed 35 minutes. (Accumulated compressor operation time)
- (iii) Outdoor heat exchanger temperature (TH1)  
When the temperature has been below -5°C for 3 minutes continuously.
- (iv) The difference between the outdoor air temperature and the outdoor heat exchanger temperature (TH2-TH1)
  - The outdoor air temperature  $\geq -2^{\circ}\text{C} : 7^{\circ}\text{C}$  or higher
  - $-15^{\circ}\text{C} < \text{The outdoor air temperature} < -2^{\circ}\text{C} : 4/15 \times \text{The outdoor air temperature} + 7^{\circ}\text{C}$  or higher
  - The outdoor air temperature  $\leq -15^{\circ}\text{C} : -5^{\circ}\text{C}$  or higher

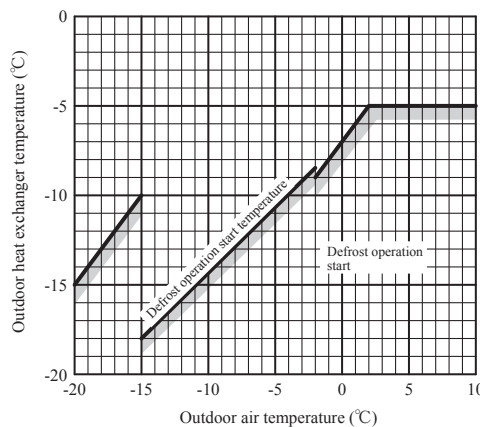

(v) During continuous compressor operation.

In addition, when the speed command from the indoor control of the indoor unit during heating operation has counted 0 rps 10 times or more and all conditions of (i), (ii) above and the outdoor air temperature is 3°C or less and the temperature for outdoor heat exchanger sensor (TH1) is -5°C or less: 62 rps or more, -4°C or less: less than 62 rps are satisfied, defrost operation is started.

- (b) Ending conditions (Operation returns to the heating cycle when either one of the following is satisfied.)
  - (i) Outdoor heat exchanger sensor (TH1) temperature: 20°C or higher.
  - (ii) Continued operation time of defrost operation → For more than 18 minutes.

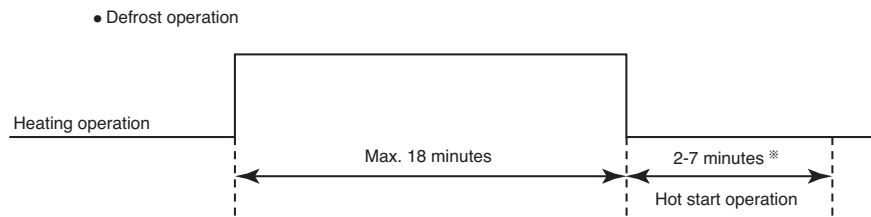

※Depends on an operation condition, the time can be longer than 7 minutes.

**(5) Cooling overload protective control**

**(a) Operating conditions**

When the outdoor air temperature (TH2) has become continuously for 30 seconds at 41°C or more, or 47°C or more with the compressor running, the lower limit speed of compressor is brought up.

Model	FDC71, 90VNP	
Outdoor air temperature	41°C or more	47°C or more
Lower limit speed	30 rps	40 rps

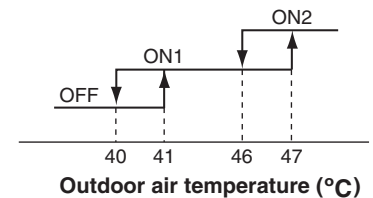

**(b) Detail of operation**

The lower limit of compressor speed is set to 30 or 40 rps and even if the calculated result becomes lower than that after fuzzy calculation, the speed is kept to 30 or 40 rps. However, when the thermostat OFF, the speed is reduced to 0 rps.

**(c) Reset conditions**

- When either of the following condition is satisfied.
  - 1) The outdoor air temperature is lower than 40°C.
  - 2) The compressor speed is 0 rps.

**(6) Cooling high pressure control**

**(a) Purpose**

Prevents anomalous high pressure operation during cooling.

**(b) Detector**

Outdoor heat exchanger sensor (TH1)

**(c) Detail of operation:**

**(Example) Fuzzy**

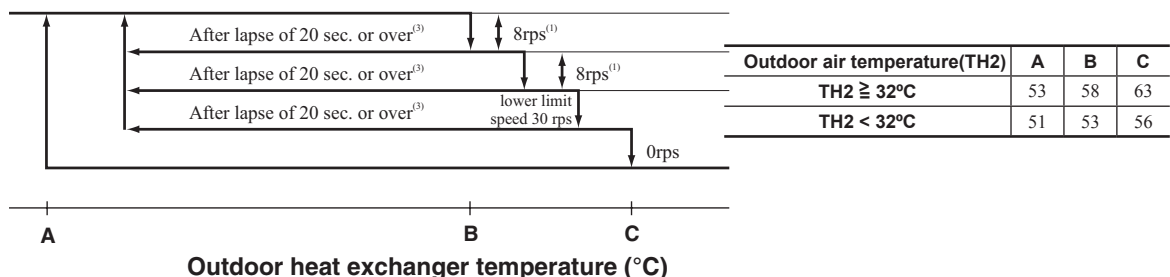

- Notes
- (1) When the outdoor heat exchanger temperature is in the range of B-C°C, the compressor speed is reduced by 8 rps at each 20 seconds.
  - (2) When the temperature is C °C or higher, the compressor is stopped.
  - (3) When the outdoor heat exchanger temperature is in the range of A-B°C, if the compressor speed is been maintained and the operation has continued for more than 20 seconds at the same speed, it returns to the normal cooling operation.

**(7) Cooling low outdoor temperature protective control**

**(a) Operating conditions**

When the outdoor air temperature (TH2) is C°C or lower continues for 20 seconds while the compressor speed is other than 0 rps.

**(b) Detail of operation**

- (i) The lower limit of the compressor speed is set to 45 (35) rps and even if the speed becomes lower than 45 (35) rps, the speed is kept to 45 (35) rps. However, when the thermostat OFF, the speed is reduced to 0 rps.
- (ii) The upper limit of the compressor speed is set to 60 <75> (75) rps and even if the calculated result becomes higher than that after fuzzy calculation, the speed is kept to 60 <75> (75) rps.

Notes (1) Values in ( ) are for outdoor air temperature is C or D  
 (2) Values in < > are for the model FDC90

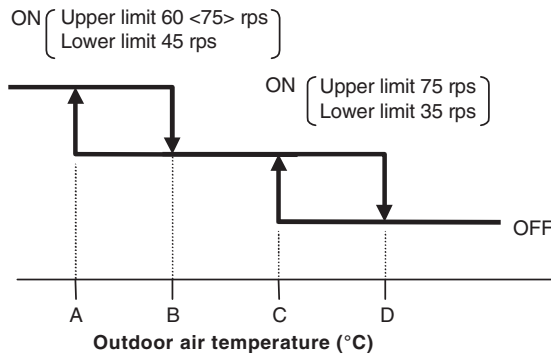

● Values of A, B, C, D  
 Model FDC71VNP

	Outdoor air temperature (°C)			
	A	B	C	D
First time	9	11	22	25
After the second time	16	19	25	28

Model FDC90VNP1

Outdoor air temperature (°C)			
A	B	C	D
9	11	22	25

**(iii) Reset conditions**

When either of the following condition is satisfied.

- 1) The outdoor air temperature (TH2) is D °C or higher.
- 2) The compressor speed is 0 rps.

**(8) Heating high pressure control**

**(a) Starting condition**

When the indoor heat exchanger temperature (Thi-R) has risen to a specified temperature while the compressor is turned on.

- (b) Compressor speed is controlled according to the zones of indoor heat exchanger temperature as shown by the following table.

	Thi-R < P1	P1 ≤ Thi-R < P2	P2 ≤ Thi-R < P3	P3 ≤ Thi-R
Protection control speed (NP)	Normal	Retention	NP-4rps	NP-8rps
Sampling time (s)	Normal	10	10	10

Model FDC71VNP Unit: °C

NP \ Thi-R	P1	P2	P3
10 ≤ NP < 50	45	52	54.5
50 ≤ NP < 115	45	52	57
115 ≤ NP < 120	45 - 43	52 - 50	57 - 55
120 ≤ NP	43	50	55

Model FDC90VNP1 Unit: °C

NP \ Thi-R	P1	P2	P3
10 ≤ NP < 90	45	52	57
90 ≤ NP < 120	45 - 43	52 - 45	57 - 48
120 ≤ NP	43	45	48

**(9) Heating overload protective control**

**(a) Operating conditions**

When the outdoor air temperature (TH2) is 13°C or higher continues for 30 seconds than 0 rps.while the compressor speed is other than 0 rps.

**(b) Detail of operation**

- (i) Taking the upper limit of compressor speed range at 90(75)rps, if the output speed obtained with the fuzzy calculation exceeds the upper limit, the upper limit value is maintained.
- (ii) The lower limit of compressor speed is set to 30(40)rps and even if the calculated result becomes lower than that after fuzzy calculation, the speed is kept to 30(40)rps. However, when the thermostat OFF, the speed is reduced to 0 prs.

Note (1) Values in ( ) are for outdoor air temperature at 17°C.



**(c) Reset conditions**

The outdoor air temperature (TH2) is lower than 11°C.

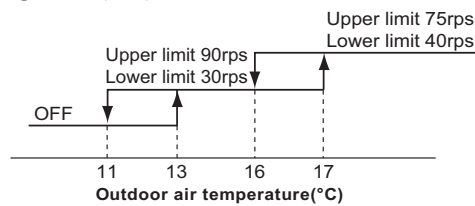

**(10) Heating low outdoor temperature protective control**

**(a) Operating conditions**

When the outdoor air temperature (TH2) is 4°C or lower continues for 30 seconds while the compressor speed is other than 0 rps.

**(b) Detail of operation**

The lower limit compressor speed is change as shown in the figure below.

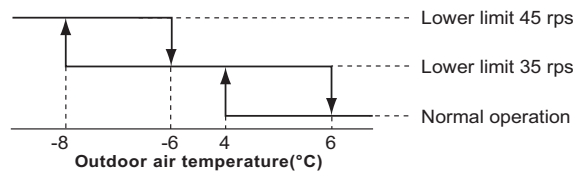

**(c) Reset conditions**

When either of the following condition is satisfied.

- (i) The outdoor air temperature (TH2) is higher than 6°C.
- (ii) The compressor speed is 0 rps.
- (iii) Compressor protection start II is activate.

**(11) Compressor overheat protection**

**(a) Purpose**

It is designed to prevent deterioration of oil, burnout of motor coil and other trouble resulting from the compressor overheat.

**(b) Detail of operation**

- (i) Speeds are controlled with temperature detected by the sensor mounted on the discharge pipe.

**(Example) Fuzzy**

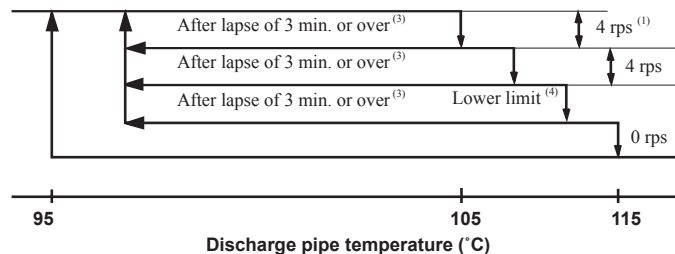

- Notes
- (1) When the discharge pipe temperature is in the range of 105-115°C, the speed is reduced by 4 rps.
  - (2) When the discharge pipe temperature is raised and continues operation for 20 seconds without changing, then the speed is reduced again by 4 rps.
  - (3) If the discharge pipe temperature is in the range of 95-105°C even when the compressor speed is maintained for 3 minutes when the temperature is in the range of 95-105°C, the speed is raised by 1 rps and kept at that speed for 3 minutes. This process is repeated until the command speed is reached.
  - (4) Lower limit speed

	Cooling	Heating
<b>Lower limit speed</b>	25 rps	32 rps

- (ii) If the temperature of 115°C is detected by the sensor on the discharge pipe, then the compressor will stop immediately. When the discharge pipe temperature drops and the time delay of 3 minutes is over, the unit starts again within 1 hour but there is no start at the third time.

**(12) Current safe**

**(a) Purpose**

Current is controlled not to exceed the upper limit of the setting operation current.

**(b) Detail of operation**

- (i) Input current to the converter is monitored with the current sensor fixed on the printed circuit board of the outdoor unit and, if the operation current value reaches the limiting current value, the compressor speed is reduced.
- (ii) If the mechanism is actuated when the compressor speed is less than 30 rps, the compressor is stopped immediately. Operation starts again after a delay time of 3 minutes.

**(13) Current cut**

**(a) Purpose**

Inverter is protected from overcurrent.

**(b) Detail of operation**

Output current from the inverter is monitored with a shunt resistor and, if the current exceeds the setting value, the compressor is stopped immediately. Operation starts again after a delay time of 3 minutes.

**(14) Outdoor unit failure**

This is a function for determining when there is trouble with the outdoor unit during air-conditioning.

The compressor is stopped if any one of the following in item (a), (b) is satisfied. Once the unit is stopped by this function, it is not restarted.

- (a) When the input current is measured at 1 A or less for 3 continuous minutes or more.
- (b) If the outdoor unit sends a 0 rps signal to the indoor unit 3 times or more within 20 minutes of the power being turned on.

**(15) Serial signal transmission error protection**

**(a) Purpose**

Prevents malfunction resulting from error on the indoor ↔ outdoor signals.

**(b) Detail of operation**

- (i) If the compressor is operating and a serial signal cannot be received from the indoor control with outdoor control having serial signals continues for 7 minutes and 35 seconds, the compressor is stopped.
- (ii) After the compressor has been stopped, it will be restarted after the compressor start delay if a serial signal can be received again from the indoor control.

**(16) Rotor lock**

If the motor for the compressor does not turn after it has been started, it is determined that a compressor lock has occurred and the compressor is stopped.

**(17) Refrigeration cycle system protection**

**(a) Starting conditions**

- (i) When 5 (Heating: 9) minutes have elapsed after the compressor ON or the completion of the defrost operation.
- (ii) Other than the defrost operation.
- (iii) When, after satisfying the conditions of (i) and (ii) above, the compressor speed, indoor air temperature (Thi-A) and indoor heat exchanger temperature (Thi-R) have satisfied the conditions in the following table for 5 minutes:

Operation mode	Compressor speed (N)	Indoor air temperature (Thi-A)	Indoor air temperature (Thi-A)/ Indoor heat exchanger temperature (Thi-R)
Cooling	$40 \leq N$	$10 \leq \text{Thi-A} \leq 40$	$\text{Thi-A} - 4 < \text{Thi-R}$
Heating	$40 \leq N$	$0 \leq \text{Thi-A} \leq 40$	$\text{Thi-R} < \text{Thi-A} + 4$

**(b) Contents of control**

- (i) When the conditions of (a) above are satisfied, the compressor stops.
- (ii) Error stop occurs when the compressor has stopped 3 times within 60 minutes.

**(c) Reset condition**

When the compressor has been turned OFF

**(18) Silent mode**

As “Silent mode start” signal is received from the remote control, it operates by dropping the outdoor fan tap.

Model	Item	Outdoor fan tap (Upper limit)
FDC71VNP		Cooling: 7th speed, Heating: 7th speed
FDC90VNP1		Cooling: 7th speed, Heating: 5th speed

**(19) Broken wire detection on temperature sensor**

- (a) Outdoor heat exchanger sensor, outdoor air temperature sensor.

If the following is detected for 5 seconds continuously within 2 minutes to 2 minutes and 20 seconds after the compressor ON, the compressor stops. After a delay of 3 minutes, it restarts but, if the same is detected repeatedly 3 times within 40 minutes, the compressor stops with the anomalous stop. Or with in 20 seconds after power ON.

Note (1) During defrost operation and for 3 minutes after the end of defrost operation, it is not detected.

- Outdoor heat exchanger temperature sensor:  $-55^{\circ}\text{C}$  or lower.
- Outdoor air temperature sensor:  $-55^{\circ}\text{C}$  or lower.

- (b) Discharge pipe temperature sensor.

If the following is detected for 5 seconds continuously within 10 minutes to 10 minutes and 20 seconds after the compressor ON, the compressor stops. After a delay of 3 minutes, it restarts but, if the same is detected repeatedly 3 times within 40 minutes, the compressor stops with the anomalous stop.

Note (1) During defrost operation and for 3 minutes after the end of defrost operation, it is not detected.

- Discharge pipe temperature sensor:  $-25^{\circ}\text{C}$  or lower.

**(II) Model FDC100VNP****(1) Compressor speed**

Unit: rps

	Cooling	Heating
Upper limit	90	90
Lower limit	15	15

**(2) Compressor protection start****(a) Operating conditions**

When the compressor is turned ON from the state of OFF.

**(b) Detail of operation:**

During the protection start control, the upper limit of compressor speed is restricted to the speeds as shown in the following table.

Unit: rps

		Time after establishment of operating conditions (Including acceleration time)					
		Less than 1 min and 45 sec	Less than 3 min	Less than 5 min	Less than 9 min	9 min or more	
Cooling		90	90	90	90	End of control	
Heating	TH2 < 0°C	THi-A ≥ 25°C	30	30	55		90
		THi-A < 25°C	55	55	55		90
	TH2 ≥ 0°C	90	90	90	90		

**(3) Outdoor fan control****(a) Outdoor fan speed and fan motor speed**Unit: min<sup>-1</sup>

Fan tap	1st speed	2nd speed	3rd speed	4th speed	5th speed	6th speed	7th speed	8th speed
Fan speed	150	300	550	650	740	820	870	950

**(b) Outdoor fan control at start (Cooling operation only)**

When the outdoor air temperature (TH2) is lower than 22°C at the start of compressor, the outdoor fan is operated at a fixed speed.

- (i) When the outdoor air temperature is higher than 11°C, the compressor runs at 2nd speed for 30 seconds after the compressor ON.
- (ii) When the outdoor air temperature is lower than 11°C, the compressor runs at 1st speed for 30 seconds after the compressor ON.

**(c) Relationship between compressor speed and outdoor fan speed**

Outdoor fan speed is controlled according to the operation mode (Heating/cooling) and the compressor speed.

Unit: rps

	1st speed	2nd speed	3rd speed	4th speed	5th speed	6th speed	7th speed	8th speed
Cooling	–	–	0-21	21-32	32-44	44-49	49-70	70-
Heating	–	–	0-21	21-30	30-48	48-60	60-67	67-

**(d) Outdoor fan control at low outdoor temperature**

**(i) Cooling**

**1) Operating conditions**

When the outdoor air temperature (TH2) is 22°C or lower continues for 30 seconds while the compressor speed is other than 0 rps.

**2) Detail of operation**

After the outdoor fan operates at A speed for 60 seconds; the corresponding outdoor heat exchanger temperature shall implement the following controls.

- Value of A

	Outdoor fan
Outdoor air temperature > 10°C	2nd speed
Outdoor air temperature ≤ 10°C	1st speed

- a) Outdoor heat exchanger temperature ≤ 22°C  
After the outdoor fan speed drops (down) to 1 speed for 60 seconds; if the outdoor heat exchanger temperature is lower than 22°C, gradually reduce the outdoor fan speed by 1 speed. (Lower limit 1st speed)
- b) 22°C < Outdoor heat exchanger temperature ≤ 40°C  
After the outdoor fan speed maintains for 20 seconds; if the outdoor heat exchanger temperature is 22°C-40°C, maintain outdoor fan speed again.
- c) Outdoor heat exchanger temperature > 40°C  
After the outdoor fan speed rises (up) to 1 speed for 60 seconds; if the outdoor heat exchanger temperature is higher than 40°C, gradually increase outdoor fan speed by 1 speed. (Upper limit 3rd speed)

**3) Reset conditions**

When either of the following conditions is satisfied.

- a) The outdoor air temperature (TH2) is 24°C or higher and fan speed is 3rd speed.
- b) The compressor speed is 0 rps.

**4) Outdoor unit fan speed and fan motor speed.**

**(ii) Heating**

**1) Operating conditions**

When the outdoor air temperature (TH2) is 3°C or lower continues for 30 seconds while the compressor speed is other than 0 rps.

**2) Detail of operation**

The outdoor fan is stepped up by 2 speed step at each 20 seconds. (Upper limit 8th speed)

**3) Reset conditions**

When either of the following conditions is satisfied.

- a) The outdoor air temperature (TH2) is 5°C or higher.
- b) The compressor speed is 0 rps.

**(e) Outdoor fan control at overload**

**(i) Cooling**

**1) Operating conditions**

When the outdoor air temperature (TH2) is 41°C or higher continues for 30 seconds while the compressor speed is other than 0 rps.

**2) Detail of operation**

The outdoor fan is stepped up by 3 speed. (Upper limit 8th speed)

**3) Reset conditions**

When either of the following conditions is satisfied.

- a) The outdoor air temperature (TH2) is 40°C or lower.
- b) The compressor speed is 0 rps.

**(ii) Heating**

**1) Operating conditions**

When the outdoor air temperature (TH2) is 13°C or higher continues for 30 seconds while the compressor speed is other than 0 rps.

**2) Detail of operation**

The outdoor fan stepped down to 3 speed.(Lower limit 2nd speed)

**3) Reset conditions**

When either of the following conditions is satisfied.

- a) The outdoor air temperature (TH2) is 11°C or lower.
- b) The compressor speed is 0 rps.

**(f) Outdoor fan motor protection**

If the outdoor fan motor has operated at 75 min<sup>-1</sup> or lower for more than 30 seconds, the compressor and fan motor are stopped.

**(4) Defrost operation**

- (a) Starting conditions (Defrost operation can be started only when all of the following conditions are satisfied.)
- (i) After start of heating operation  
When it elapsed 35 minutes. (Accumulated compressor operation time)
  - (ii) After end of defrost operation  
When it elapsed 35 minutes. (Accumulated compressor operation time)
  - (iii) Outdoor heat exchanger temperature (TH1)  
When the temperature has been below  $-5^{\circ}\text{C}$  for 3 minutes continuously.
  - (iv) The difference between the outdoor air temperature and the outdoor heat exchanger temperature (TH2-TH1)
    - The outdoor air temperature  $\geq -2^{\circ}\text{C}$  :  $7^{\circ}\text{C}$  or higher
    - $-15^{\circ}\text{C} < \text{The outdoor air temperature} < -2^{\circ}\text{C}$  :  $4/15 \times \text{The outdoor air temperature} + 7^{\circ}\text{C}$  or higher
    - The outdoor air temperature  $\leq -15^{\circ}\text{C}$  :  $-5^{\circ}\text{C}$  or higher

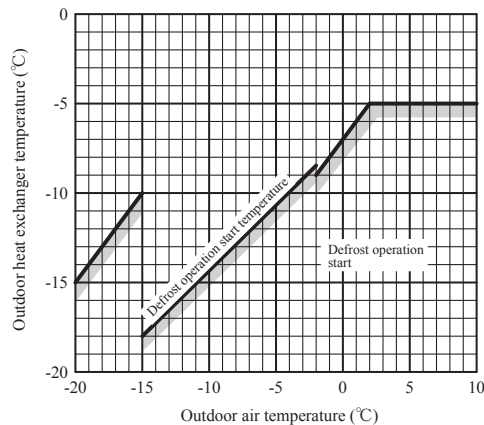

- (v) During continuous compressor operation  
In addition, when the speed command from the indoor control of the indoor unit during heating operation has counted 0 rps 10 times or more and all conditions of (i), (ii) above and the outdoor air temperature is  $3^{\circ}\text{C}$  or less and the temperature for outdoor heat exchanger temperature (TH1) is  $-5^{\circ}\text{C}$  or less: 62 rps or more,  $-4^{\circ}\text{C}$  or less: less than 62 rps are satisfied, defrost operation is started.
- (b) Ending condition (Operation returns to the heating cycle when either one of the following is satisfied.)
- (i) Outdoor heat exchanger sensor (TH1) temperature:  $13^{\circ}\text{C}$  or higher.
  - (ii) Continued operation time of defrost operation  $\rightarrow$  For more than 18 minutes.

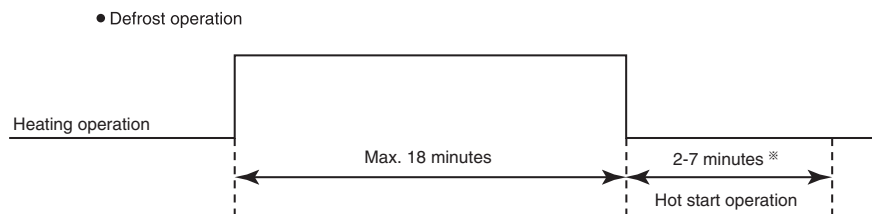

※Depends on an operation condition, the time can be longer than 7 minutes.

**(5) Cooling overload protective control**

**(a) Operating conditions**

When the outdoor air temperature (TH2) has become continuously for 30 seconds at 36°C or more, or 47°C or more with the compressor running, the lower limit speed of compressor is brought up.

Item	Model	
	FDC100VNP	
Outdoor air temperature	36°C or more	47°C or more
Lower limit speed	20 rps	25 rps

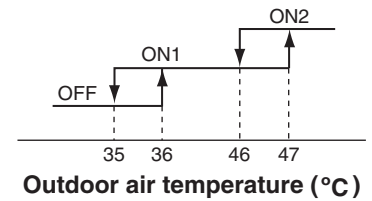

**(b) Detail of operation**

The lower limit of compressor speed is set to 20 or 25 rps and even if the calculated result becomes lower than that after fuzzy calculation, the speed is kept to 20 or 25 rps. However, when the thermostat OFF, the speed is reduced to 0 rps.

**(c) Reset condition**

When either of the following condition is satisfied.

- 1) The outdoor air temperature is lower than 35°C.
- 2) The compressor speed is 0 rps.

**(6) Cooling high pressure control**

**(a) Purpose**

Prevents anomalous high pressure operation during cooling.

**(b) Detector**

Outdoor heat exchanger sensor (TH1)

**(c) Detail of operation**

**(Example) Fuzzy**

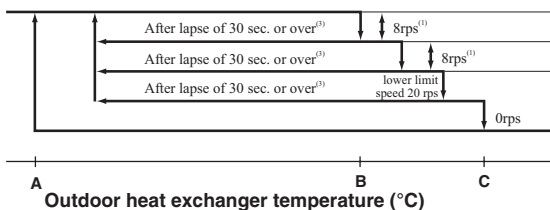

Outdoor air temperature(TH2)	A	B	C
TH2 ≥ 32°C	53	58	60
TH2 < 31°C	51	53	56

- Notes (1) When the outdoor heat exchanger temperature is in the range of B - C °C, the compressor speed is reduced by 8 rps at each 20 seconds.  
 (2) When the temperature is C °C or higher, the compressor is stopped.  
 (3) When the outdoor heat exchanger temperature is in the range of A - B °C, if the compressor speed is been maintained and the operation has continued for more than 30 seconds at the same speed, it returns to the normal cooling operation.

**(7) Cooling low outdoor temperature protective control**

**(a) Operating condition**

When the outdoor air temperature (TH2) is C°C or lower continues for 20 seconds while the compressor speed is other than 0 rps.

**(b) Detail of operation**

- (i) The lower limit of the compressor speed is set to 40 (A) rps and even if the speed becomes lower than 40 (A) rps, the speed is kept to 40 (A) rps. However, when the thermo OFF, the speed is reduced to 0 rps.
- (ii) The upper limit of the compressor speed is set to 50 (65) rps and even if the calculated result becomes higher than that after fuzzy calculation, the speed is kept to 50 (65) rps.

Note (1) Values in ( ) are for outdoor air temperature is C or D

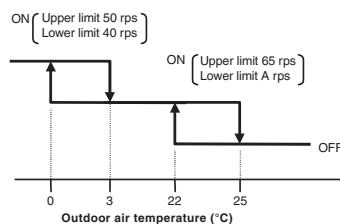

● Value of A

	A
Outdoor air temperature ≥ 26°C	Release
Outdoor air temperature < 24°C	25

**(iii) Reset condition**

When either of the following condition is satisfied.

- 1) The outdoor air temperature (TH2) is 25 °C or higher.
- 2) The compressor speed is 0 rps.

**(8) Heating high pressure control**

**(a) Starting condition**

When the indoor heat exchanger temperature (Thi-R) has risen to a specified temperature while the compressor is turned on.

(b) Compressor speed is controlled according to the zones of indoor heat exchanger temperature as shown by the following table.

	Thi-R < P1	P1 ≤ Thi-R < P2	P2 ≤ Thi-R < P3	P3 ≤ Thi-R
Protection control speed (NP)	Normal	Retention	NP-4rps	NP-8rps
Sampling time (s)	Normal	20	20	20

Unit: °C

NP	Thi-R	P1	P2	P3
10 ≤ NP < 90		45	52	57
90 ≤ NP < 120		45 - 43	52 - 45	57 - 48
120 ≤ NP		43	45	48

**(9) Heating overload protective control I**

**(a) Operating conditions**

When the outdoor air temperature (TH2) is 13°C or higher continues for 30 seconds while the compressor speed is other than 0 rps.

**(b) Detail of operation**

- (i) Taking the upper limit of compressor speed range at 65(35)rps, if the output speed obtained with the fuzzy calculation exceeds the upper limit, the upper limit value is maintained.
- (ii) The lower limit of compressor speed is set to 25(30)rps and even if the calculated result becomes lower than that after fuzzy calculation, the speed is kept to 25(30)rps. However, when the thermostat OFF, the speed is reduced to 0 rps.

Note (1) Values in ( ) are for outdoor air temperature at 17°C.

**(c) Reset condition**

The outdoor air temperature (TH2) is lower than 11°C.

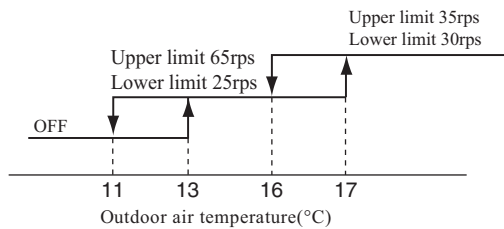

**(10) Heating overload protective control II**

**(a) Starting condition**

When the indoor heat exchanger temperature (Thi-R) has risen to a specified temperature while the compressor is turned on.

**(b) Detail of operation**

The lower limit of compressor command speed is set to 20rps.

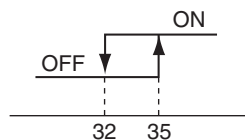

Indoor heat exchanger temperature (°C)



**(11) Heating low outdoor temperature protective control**

**(a) Operating conditions**

When the outdoor air temperature (TH2) is 4°C or lower continues for 30 seconds while the compressor speed is other than 0 rps.

**(b) Detail of operation**

The lower limit compressor speed is changed as shown in the figure below.

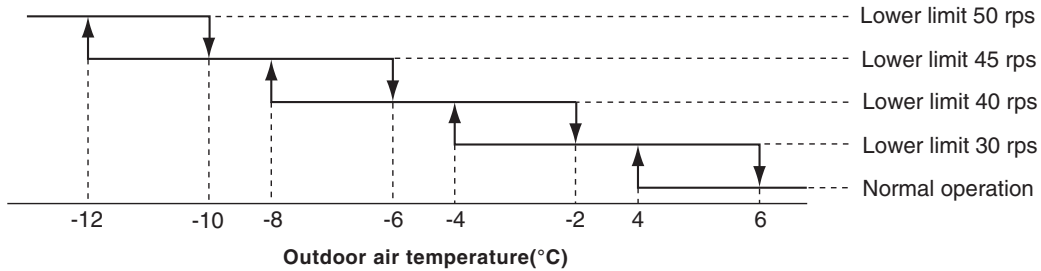

**(c) Reset condition**

When either of the following condition is satisfied.

- (i) The outdoor air temperature (TH2) is higher than 6°C
- (ii) The compressor speed is 0 rps.

**(12) Compressor overheat protection**

**(a) Purpose**

It is designed to prevent deterioration of oil, burnout of motor coil and other trouble resulting from the compressor overheat.

**(b) Detail of operation**

- (i) Speeds are controlled with temperature detected by the sensor mounted on the discharge pipe.

(Example) Fuzzy

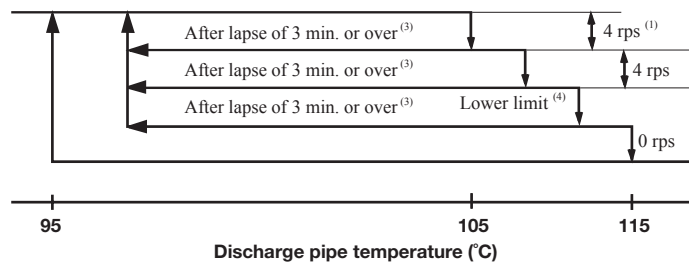

- Notes (1) When the discharge pipe temperature is in the range of 105-115°C, the speed is reduced by 4 rps.
- (2) When the discharge pipe temperature is raised and continues operation for 20 seconds without changing, then the speed is reduced again by 4 rps.
- (3) If the discharge pipe temperature is in the range of 95-105°C even when the compressor speed is maintained for 3 minutes when the temperature is in the range of 95-105°C, the speed is raised by 1 rps and kept at that speed for 3 minutes. This process is repeated until the command speed is reached.
- (4) Lower limit speed

	Cooling	Heating
Lower limit speed	20 rps	25 rps

- (ii) If the temperature of 115°C is detected by the sensor on the discharge pipe, then the compressor will stop immediately. When the discharge pipe temperature drops and the time delay of 3 minutes is over, the unit starts again within 1 hour but there is no start at the third time.

**(13) Current safe**

**(a) Purpose**

Current is controlled not to exceed the upper limit of the setting operation current.

**(b) Detail of operation**

- (i) Input current to the converter is monitored with the current sensor fixed on the printed circuit board of the outdoor unit and, if the operation current value reaches the limiting current value, the compressor speed is reduced.
- (ii) If the mechanism is actuated when the compressor speed is less than 20 rps, the compressor is stopped immediately. Operation starts again after a delay time of 3 minutes.

**(14) Current cut****(a) Purpose**

Inverter is protected from overcurrent.

**(b) Detail of operation**

Output current from the inverter is monitored with a shunt resistor and, if the current exceeds the setting value, the compressor is stopped immediately. Operation starts again after a delay time of 3 minutes.

**(15) Outdoor unit failure**

This is a function for determining when there is trouble with the outdoor unit during air-conditioning.

The compressor is stopped if any one of the following in item (a), (b) is satisfied. Once the unit is stopped by this function, it is not restarted.

- (a) When the input current is measured at 1 A or less for 3 continuous minutes or more.
- (b) If the outdoor unit sends a 0 rps signal to the indoor unit 3 times or more within 20 minutes of the power being turned on.

**(16) Serial signal transmission error protection****(a) Purpose**

Prevents malfunction resulting from error on the indoor ↔ outdoor signals.

**(b) Detail of operation**

- (i) If the compressor is operating and a serial signal cannot be received from the indoor control with outdoor control having serial signals continues for 7 minutes and 35 seconds, the compressor is stopped.
- (ii) After the compressor has been stopped, it will be restarted after the compressor start delay if a serial signal can be received again from the indoor control.

**(17) Rotor lock**

If the motor for the compressor does not turn after it has been started, it is determined that a compressor lock has occurred and the compressor is stopped.

**(18) Refrigeration cycle system protection****(a) Starting conditions**

- (i) When S minutes have elapsed after the compressor ON or the completion of the defrost operation
- (ii) Other than the defrost operation
- (iii) When, after meeting the conditions of (i) and (ii) above, the compressor speed, indoor air temperature (Thi-A) and indoor heat exchanger temperature (Thi-R) have satisfied the conditions in the following table for 5 minutes:

Operation mode	S (min)	Compressor speed (N)	Indoor air temperature (Thi-A)	Indoor air temperature (Thi-A)/ Indoor heat exchanger temperature (Thi-R)
Cooling	5	$30 \leq N$	$10 \leq \text{Thi-A} \leq 40$	$\text{Thi-A} - 4 < \text{Thi-R}$
Heating	5	$30 \leq N$	$0 \leq \text{Thi-A} \leq 40$	$\text{Thi-A} + 6 > \text{Thi-R}$

**(b) Contents of control**

- (i) When the conditions of (a) above are satisfied, the compressor stops.
- (ii) Error stop occurs when the compressor has stopped 3 times within 60 minutes.

**(c) Resetting condition**

When the compressor has been turned OFF.

**(19) Silent mode**

As "Silent mode start" signal is received from the remote control, it operates by dropping the outdoor fan tap.

	Outdoor fan tap (Upper limit)
Cooling	3rd speed
Heating	3rd speed

**(20) Broken wire detection on temperature sensor**

- (a) Outdoor heat exchanger temperature sensor, outdoor air temperature sensor

If the following is detected for 5 seconds continuously within 2 minutes to 2 minutes and 20 seconds after the compressor ON, the compressor stops. After a delay of 3 minutes, it restarts but, if the same is detected repeatedly 3 times within 40 minutes, the compressor stops with the anomalous stop. Or with in 20 seconds after power ON.

Note (1) During defrost operation and for 3 minutes after the end of defrost operation, it is not detected.

- Outdoor heat exchanger temperature sensor: -55°C or lower
- Outdoor air temperature sensor: -55°C or lower

- (b) Discharge pipe temperature sensor

If the following is detected for 5 seconds continuously within 10 minutes to 10 minutes and 20 seconds after the compressor ON, the compressor stops. After a delay of 3 minutes, it restarts but, if the same is detected repeatedly 3 times within 40 minutes, the compressor stops with the anomalous stop.

Note (1) During defrost operation and for 3 minutes after the end of defrost operation, it is not detected.

- Discharge pipe temperature sensor: -25°C or lower

**(21) Base heater ON/OFF output control (Option)**

- (a) Base heater ON conditions**

When all of following conditions are satisfied, the base heater is turned ON.

- (i) Outdoor air temperature (detected with Tho-A) is 3°C or lower.
- (ii) In the heating mode
- (iii) When the compressor is turned ON

- (b) Base heater OFF conditions**

When either one of following conditions is satisfied, the base heater is turned OFF.

- (i) Outdoor air temperature (detected with Tho-A) is 5°C or higher.
- (ii) When the compressor stop has been detected for 30 minutes continuously
- (iii) In the cooling or dehumidifying mode

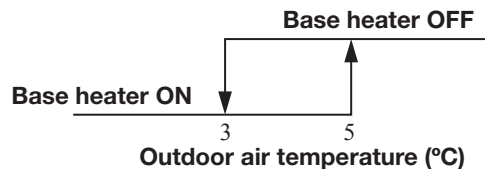

**(22) Reverse operation start for compressor protection**

- (a) Purpose**

It is designed to prevent compressor failure at heating mode.

- (b) Detail of operation**

When the outdoor air temperature (TH2) is 10°C or lower and compressor is not operated for long time, the unit starts cooling mode up to 7 minutes at heating mode.

- (c) Method for disabling this operation**

When outdoor unit is installed higher than indoor unit, you can disable this control by cutting jumper (J2) of PCB of outdoor unit.

Note(1) Unit may failure if you disable this control without above installation condition.

## 3.2 MAINTENANCE DATA

See page 40 of 1.2 chapter.

### 3.3 ELECTRICAL WIRING

- (1) Indoor units ..... See page 166.
- (2) Outdoor units  
Model FDC71VNP

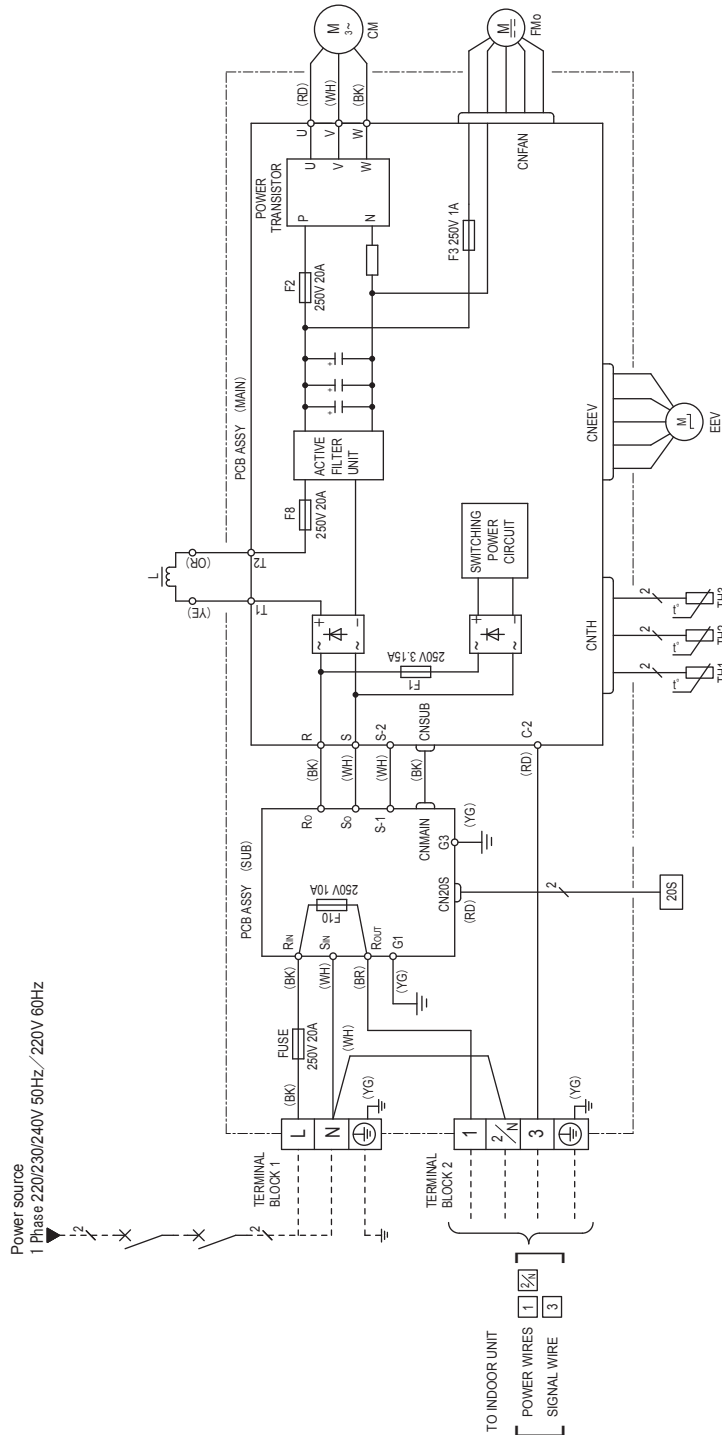

Power cable, indoor-outdoor connecting wires

Model	MAX running current (A)	Power cable size (mm <sup>2</sup> )	Power cable length (m)	Indoor-outdoor wire size x number	Earth wire size (mm <sup>2</sup> )
FDC71	14.5	2.0	15	1.5mm <sup>2</sup> x 4	1.5

- The specifications shown in the above table are for units without heaters. For units with heaters, refer to the installation instructions or the construction instructions of the indoor unit.
- Switchgear of circuit breaker capacity which is calculated from MAX. over current should be chosen along the regulations in each country.
- The cable specifications are based on the assumption that a metal or plastic conduit is used with no more than three cables contained in a conduit and a voltage drop is 2%. For an installation falling outside of these conditions, please follow the internal cabling regulations. Adapt it to the regulation in effect in each country.

Meaning of marks

Item	Description
CM	Compressor motor
CN20S	Connector
CNTH	
CNEEV	
CNFAN	
EEV	Electric expansion valve (Coil)
FMO	Fan motor
L	Reactor
TH1	Heat exchanger temperature sensor (Outdoor unit)
TH2	Outdoor air temperature sensor
TH3	Discharge pipe temperature sensor
ZOS	Solenoid coil for 4-way valve

Color marks

Mark	Color
BK	Black
BR	Brown
OR	Orange
RD	Red
WH	White
YE	Yellow
YG	Yellow/Green

PCA001Z715

Model FDC90VNP1

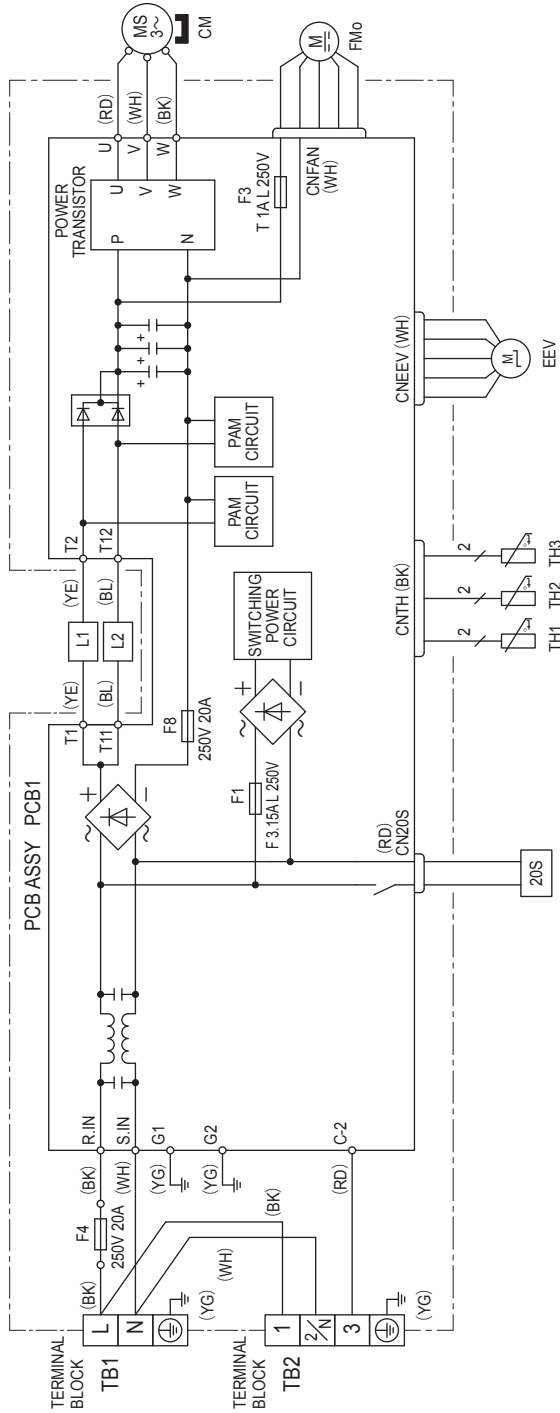

Power cable, indoor-outdoor connecting wires

Model	MAX running current (A)	Power cable size (mm <sup>2</sup> )	indoor-outdoor wire size x number	Earth wire size (mm <sup>2</sup> )
90	18	2.5	1.5mm <sup>2</sup> x4	1.5

- The specifications shown in the above table are for units without heaters. For units with heaters, refer to the installation instructions or the construction instructions of the indoor unit.
- Switchgear of circuit breaker capacity which is calculated from MAX. over current should be chosen along the regulations in each country.
- The cable specifications are based on the assumption that a metal or plastic conduit is used with no more than three cables contained in a conduit and a voltage drop is 2%. For an installation falling outside of these conditions, please follow the internal cabling regulations. Adapt it to the regulation in effect in each country.

Meaning of marks

20S	4-WAY VALVE (COIL)
CM	COMPRESSOR MOTOR
EEV	ELECTRIC EXPANSION VALVE (COIL)
FM0	FAN MOTOR
L1,2	REACTOR
TH1	HEAT EXCHANGER TEMPERATURE SENSOR
TH2	OUTDOOR AIR TEMPERATURE SENSOR
TH3	DISCHARGE PIPE TEMPERATURE SENSOR

Color marks

Mark	Color	MARK	COLOR
BK	BLACK	YE	YELLOW
BL	BLUE	YG	YELLOW/ GREEN
RD	RED		
WH	WHITE		

Model FDC100VNP

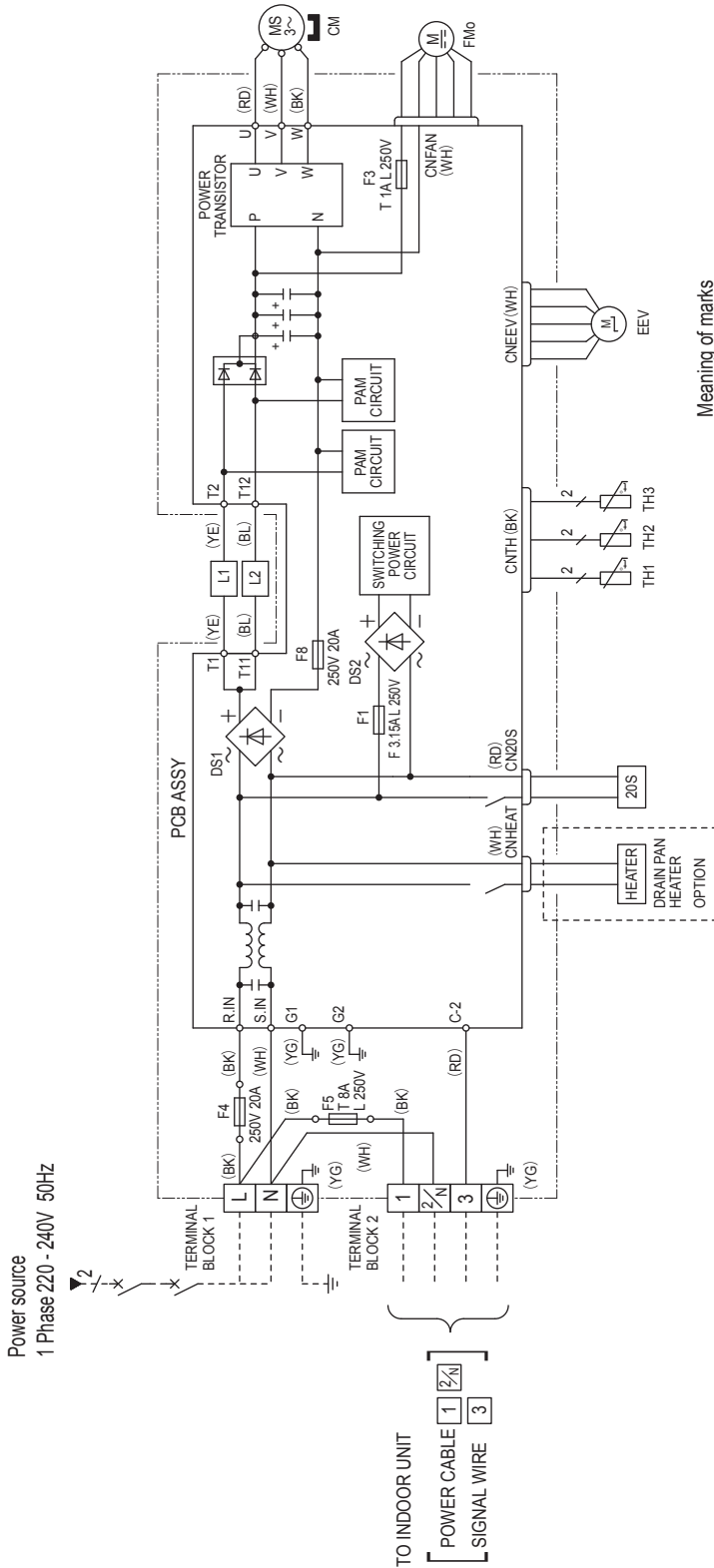

Power cable, indoor-outdoor connecting wires

MODEL NAME	MAX running current (A)	Power cable size (mm <sup>2</sup> )	Power cable length (m)	indoor-outdoor wire size x number (mm)	Earth wire size (mm)
FDC100VNP	21	5.5	25	φ1.6 × 3	φ1.6

- The specifications shown in the above table are for units without heaters. For units with heaters, refer to the installation instructions or the construction instructions of the indoor unit.
- Switchgear of circuit breaker capacity which is calculated from MAX. over current should be chosen along the regulations in each country.
- The cable specifications are based on the assumption that a metal or plastic conduit is used with no more than three cables contained in a conduit and a voltage drop is 2%. For an installation falling outside of these conditions, please follow the internal cabling regulations. Adapt it to the regulation in effect in each country.

Color marks

Mark	Color
BK	Black
BL	Blue
RD	Red
WH	White
YE	Yellow
YG	Yellow / Green

Meaning of marks

Item	Description
20S	Solenoid coil for 4-way valve
CN20S	Connector
CNEEV	Compressor motor
CNFAN	Diode stack
CNHEAT	Electric expansion valve (Coil)
CNTH	Fan motor
CM	Reactor
DS1,2	Heat exchanger temperature sensor
EEV	Outdoor air temperature sensor
FMo	Discharge pipe temperature sensor
L1,2	Jumper (※)
TH1	
TH2	
TH3	
J2	

Note(1) ※ By cutting J2, the operation of cooling start in heating mode is disablement.

PCA001Z788

### 3.4 PIPING SYSTEM

Model FDT71

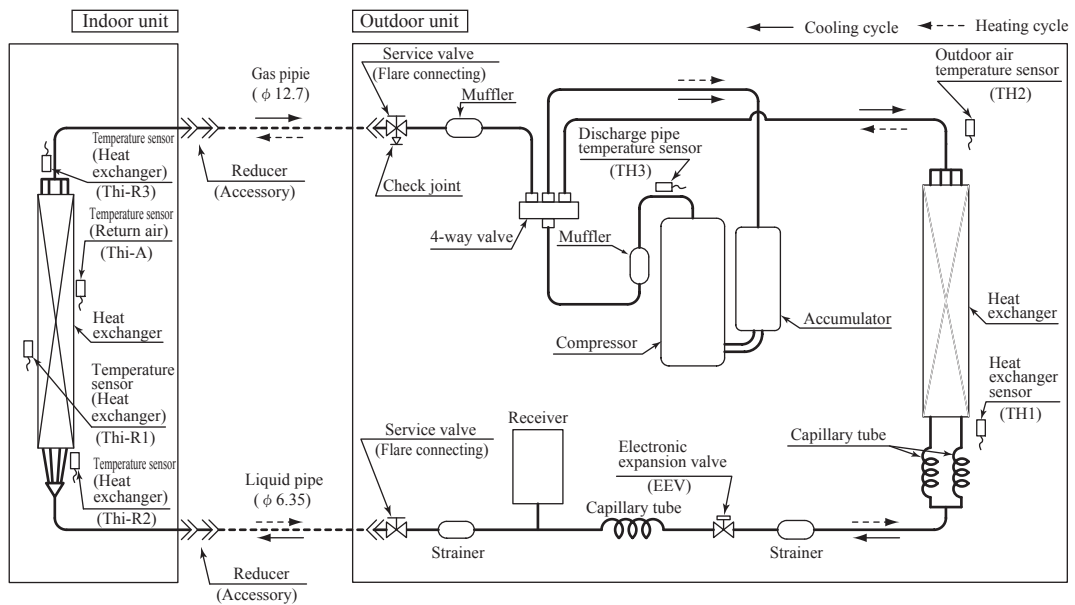

Model FDT90

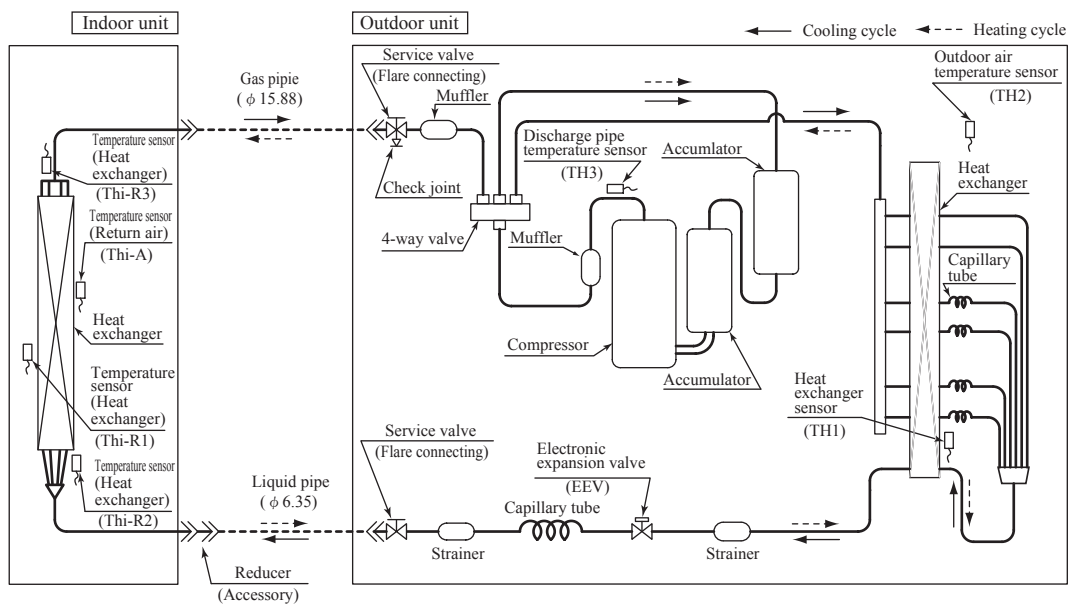

**Model FDT100**

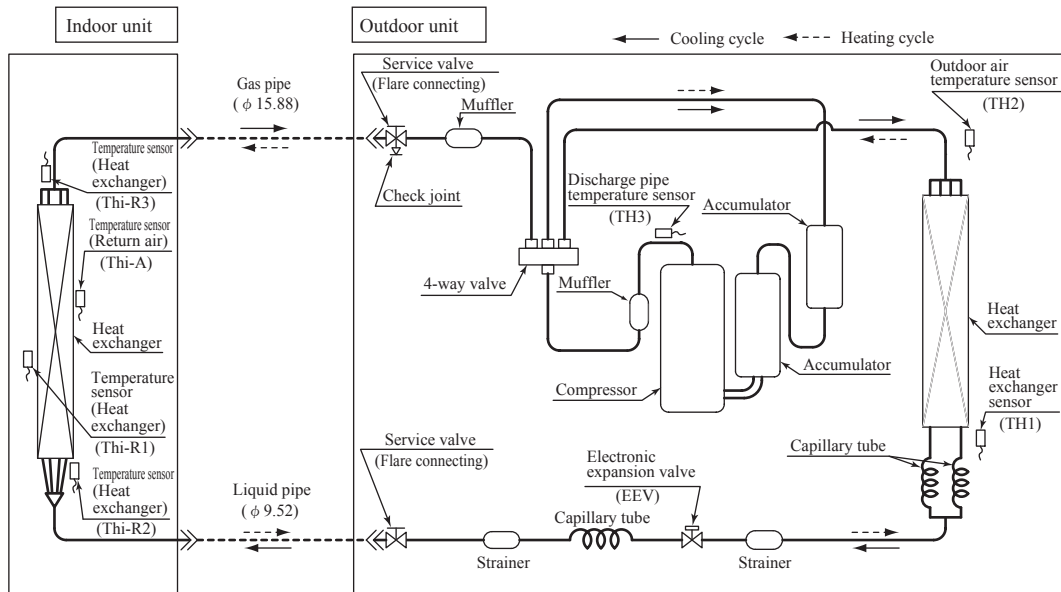

**Preset point of the protective devices**

Parts name	Mark	Equipped unit	All models
Temperature sensor (for protection overloading in heating)	Thi-R	Indoor unit	OFF 63°C , ON 56°C
Temperature sensor (for frost prevention)			OFF 1.0°C , ON 10°C
Temperature sensor (for protection high pressure in cooling)	TH1	Outdoor unit	OFF 63°C , ON 53°C
Temperature sensor (for detecting discharge pipe temperature)	TH3		OFF 115°C , ON 95°C



## 4. V MULTI SYSTEM

### TABLE OF CONTENTS

4.1 HYPER INVERTER PACKAGED AIR-CONDITIONERS .....	223
4.2 MICRO INVERTER PACKAGED AIR-CONDITIONERS .....	225

## 4.1 HYPER INVERTER PACKAGED AIR-CONDITIONERS

### CONTENTS

4.1.1 OUTLINE OF OPERATION CONTROL BY MICROCOMPUTER .....	224
4.1.2 MAINTENANCE DATA .....	224
4.1.3 ELECTRICAL WIRING .....	224
4.1.4 PIPING SYSTEM .....	224

**4.1.1 OUTLINE OF OPERATION CONTROL BY MICROCOMPUTER .....See page 4**  
**4.1.2 MAINTENANCE DATA .....See page 40**  
**4.1.3 ELECTRICAL WIRING**  
    (1) Indoor units .....See page 166  
    (2) Outdoor units .....See page 168  
**4.1.4 PIPING SYSTEM .....See page 170**

## 4.2 MICRO INVERTER PACKAGED AIR-CONDITIONERS

### CONTENTS

4.2.1 OUTLINE OF OPERATION CONTROL BY MICROCOMPUTER .....	226
4.2.2 MAINTENANCE DATA .....	226
4.2.3 ELECTRICAL WIRING .....	226
4.2.4 PIPING SYSTEM .....	226

**4.2.1 OUTLINE OF OPERATION CONTROL BY MICROCOMPUTER ..... See page 173**

**4.2.2 MAINTENANCE DATA ..... See page 192**

**4.2.3 ELECTRICAL WIRING**

    (1) Indoor units ..... See page 193

    (2) Outdoor units ..... See page 193

**4.2.4 PIPING SYSTEM ..... See page 197**

---

# **INVERTER PACKAGED AIR-CONDITIONERS**

---



---

**MITSUBISHI HEAVY INDUSTRIES THERMAL SYSTEMS, LTD.**

2-3, Marunouchi 3-chome, Chiyoda-ku, Tokyo, 100-8332, Japan  
<http://www.mhi-mth.co.jp/en/>

Because of our policy of continuous improvement, we reserve the right to make changes in all specifications without notice.

© Copyright MITSUBISHI HEAVY INDUSTRIES THERMAL SYSTEMS, LTD.